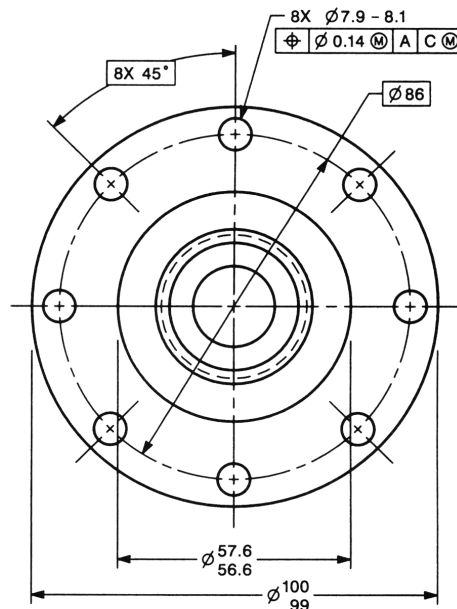


**ASME Y14.5-2009**  
[Revision of ASME Y14.5M-1994 (R2004)]

# Dimensioning and Tolerancing

## Engineering Drawing and Related Documentation Practices



**AN INTERNATIONAL STANDARD**



The American Society of  
Mechanical Engineers



## ADOPTION NOTICE

ASME Y14.5, Dimensioning and Tolerancing, was adopted on 9 February 2009 for use by the Department of Defense (DoD). Proposed changes by DoD activities must be submitted to the DoD Adopting Activity: Commander, U.S. Army Research, Development and Engineering Center (ARDEC), ATTN: AMSRD-AAR-QES-E, Picatinny Arsenal, NJ 07806-5000. Copies of this document may be purchased from The American Society of Mechanical Engineers (ASME), 22 Law Drive, P.O. Box 2900, Fairfield, NJ 07007-2900, <http://www.asme.org>.

Custodians:

Army — AR  
Navy — SA  
Air Force — 16

Adopting Activity:

Army — AR  
(Project DRPR-2009-003)

Review Activities:

Army — CR, IE, MI, PT, TM2  
Navy — AS, CG, CH, EC, MC, NP, TD  
Air Force — 13, 99  
DLA — DH  
OSD — SE  
NSA — NS  
Other — CM, MP, DC2

NOTE: The activities listed above were interested in this document as of the date of this document. Since organizations and responsibilities can change, you should verify the currency of the information above using the ASSIST Online database at <http://assist.daps.dla.mil>.

AMSC N/A

AREA DRPR

DISTRIBUTION STATEMENT A. Approved for public release; distribution is unlimited.

**ASME Y14.5-2009**  
[Revision of ASME Y14.5M-1994 (R2004)]

# Dimensioning and Tolerancing

---

**Engineering Drawing and Related  
Documentation Practices**

**AN INTERNATIONAL STANDARD**



Date of Issuance: March 27, 2009

This Standard will be revised when the Society approves the issuance of a new edition. There will be no addenda or written interpretations of the requirements of this Standard issued to this edition.

Periodically certain actions of the ASME Y14 Committee may be published as Cases. Cases are published on the ASME Web site under the Committee Pages at <http://cstools.asme.org> as they are issued.

ASME is the registered trademark of The American Society of Mechanical Engineers.

This code or standard was developed under procedures accredited as meeting the criteria for American National Standards. The Standards Committee that approved the code or standard was balanced to assure that individuals from competent and concerned interests have had an opportunity to participate. The proposed code or standard was made available for public review and comment that provides an opportunity for additional public input from industry, academia, regulatory agencies, and the public-at-large.

ASME does not "approve," "rate," or "endorse" any item, construction, proprietary device, or activity.

ASME does not take any position with respect to the validity of any patent rights asserted in connection with any items mentioned in this document, and does not undertake to insure anyone utilizing a standard against liability for infringement of any applicable letters patent, nor assumes any such liability. Users of a code or standard are expressly advised that determination of the validity of any such patent rights, and the risk of infringement of such rights, is entirely their own responsibility.

Participation by federal agency representative(s) or person(s) affiliated with industry is not to be interpreted as government or industry endorsement of this code or standard.

ASME accepts responsibility for only those interpretations of this document issued in accordance with the established ASME procedures and policies, which precludes the issuance of interpretations by individuals.

No part of this document may be reproduced in any form,  
in an electronic retrieval system or otherwise,  
without the prior written permission of the publisher.

The American Society of Mechanical Engineers  
Three Park Avenue, New York, NY 10016-5990

Copyright © 2009 by  
THE AMERICAN SOCIETY OF MECHANICAL ENGINEERS  
All rights reserved  
Printed in U.S.A.

# CONTENTS

Foreword .....	vi
Committee Roster .....	viii
Correspondence With the Y14 Committee .....	ix
<b>Section 1 Scope, Definitions, and General Dimensioning .....</b>	<b>1</b>
1.1 Scope .....	1
1.2 References .....	1
1.3 Definitions .....	2
1.4 Fundamental Rules .....	7
1.5 Units of Measure .....	8
1.6 Types of Dimensioning .....	9
1.7 Application of Dimensions .....	10
1.8 Dimensioning Features .....	13
1.9 Location of Features .....	20
<b>Section 2 General Tolerancing and Related Principles .....</b>	<b>24</b>
2.1 General .....	24
2.2 Direct Tolerancing Methods .....	24
2.3 Tolerance Expression .....	25
2.4 Interpretation of Limits .....	26
2.5 Single Limits .....	26
2.6 Tolerance Accumulation .....	26
2.7 Limits of Size .....	27
2.8 Applicability of Modifiers on Geometric Tolerance Values and Datum Feature References .....	29
2.9 Screw Threads .....	31
2.10 Gears and Splines .....	31
2.11 Boundary Conditions .....	31
2.12 Angular Surfaces .....	31
2.13 Conical Tapers .....	35
2.14 Flat Tapers .....	35
2.15 Radius .....	36
2.16 Tangent Plane .....	36
2.17 Statistical Tolerancing .....	36
<b>Section 3 Symbology .....</b>	<b>38</b>
3.1 General .....	38
3.2 Use of Notes to Supplement Symbols .....	38
3.3 Symbol Construction .....	38
3.4 Feature Control Frame Symbols .....	44
3.5 Feature Control Frame Placement .....	46
3.6 Definition of the Tolerance Zone .....	46
3.7 Tabulated Tolerances .....	46
<b>Section 4 Datum Reference Frames .....</b>	<b>48</b>
4.1 General .....	48
4.2 Degrees of Freedom .....	48
4.3 Degrees of Freedom Constrained by Primary Datum Features Regardless of Material Boundary .....	48
4.4 Constraining Degrees of Freedom of a Part .....	48
4.5 Datum Feature Simulator .....	53
4.6 Theoretical and Physical Application of Datum Feature Simulators .....	53
4.7 Datum Reference Frame .....	53

4.8	Datum Features .....	57
4.9	Datum Feature Controls .....	58
4.10	Specifying Datum Features in an Order of Precedence .....	58
4.11	Establishing Datums .....	59
4.12	Multiple Datum Features .....	65
4.13	Mathematically Defined Surface .....	69
4.14	Multiple Datum Reference Frames .....	69
4.15	Functional Datum Features .....	69
4.16	Rotational Constraint About a Datum Axis or Point .....	70
4.17	Application of MMB, LMB, and RMB to Irregular Features of Size .....	74
4.18	Datum Feature Selection Practical Application .....	75
4.19	Simultaneous Requirements .....	76
4.20	Restrained Condition .....	79
4.21	Datum Reference Frame Identification .....	79
4.22	Customized Datum Reference Frame Construction .....	81
4.23	Application of a Customized Datum Reference Frame .....	81
4.24	Datum Targets .....	83
<b>Section 5</b>	<b>Tolerances of Form .....</b>	<b>91</b>
5.1	General .....	91
5.2	Form Control .....	91
5.3	Specifying Form Tolerances .....	91
5.4	Form Tolerances .....	91
5.5	Application of Free-State Symbol .....	95
<b>Section 6</b>	<b>Tolerances of Orientation .....</b>	<b>99</b>
6.1	General .....	99
6.2	Orientation Control .....	99
6.3	Orientation Symbols .....	99
6.4	Specifying Orientation Tolerances .....	99
6.5	Tangent Plane .....	103
6.6	Alternative Practice .....	103
<b>Section 7</b>	<b>Tolerances of Location .....</b>	<b>108</b>
7.1	General .....	108
7.2	Positional Tolerancing .....	108
7.3	Positional Tolerancing Fundamentals: I .....	108
7.4	Positional Tolerancing Fundamentals: II .....	119
7.5	Pattern Location .....	127
7.6	Coaxial Feature Controls .....	148
7.7	Tolerancing for Symmetrical Relationships .....	156
<b>Section 8</b>	<b>Tolerances of Profile .....</b>	<b>158</b>
8.1	General .....	158
8.2	Profile .....	158
8.3	Tolerance Zone Boundaries .....	158
8.4	Profile Applications .....	165
8.5	Material Condition and Boundary Condition Modifiers as Related to Profile Controls .....	167
8.6	Composite Profile .....	167
8.7	Multiple Single-Segment Profile Tolerancing .....	175
8.8	Combined Controls .....	175
<b>Section 9</b>	<b>Tolerances of Runout .....</b>	<b>180</b>
9.1	General .....	180
9.2	Runout .....	180
9.3	Runout Tolerance .....	180
9.4	Types of Runout Tolerances .....	180
9.5	Application .....	182
9.6	Specification .....	182

<b>Nonmandatory Appendices</b>		
A	Principal Changes and Improvements .....	185
B	Formulas for Positional Tolerancing .....	191
C	Form, Proportion, and Comparison of Symbols .....	194
D	Former Practices .....	199
E	Decision Diagrams for Geometric Control .....	200
<b>Index</b>	.....	<b>207</b>

# FOREWORD

This issue is a revision of ASME Y14.5M-1994, Dimensioning and Tolerancing. The main object for this revision has been to rearrange the material to better direct the thought process of the user when applying Geometric Dimensioning and Tolerancing. The subject matter of Sections 1 through 4 remains the same as in the previous revision. Sections 5 and 6 were formerly titled "Tolerances of Location" and "Tolerances of Form, Profile, Orientation, and Runout." The new order following Section 4, Datums, is Section 5, Tolerances of Form; Section 6, Tolerances of Orientation; Section 7, Tolerances of Location; Section 8, Tolerances of Profile; and Section 9, Tolerances of Runout. When applying GD&T the first consideration is to establish a datum reference frame based on the function of the part in the assembly with its mating parts. After the datum reference frame is established, the form of the primary datum feature is controlled, followed by the orientation and/or location of the secondary and tertiary datum features. After the datum features are related relative to each other, the remaining features are controlled for orientation and location relative to the datum reference framework. Further rearrangement has occurred within each section so that the basic concepts are presented first and then the material builds to the more complex. The subcommittee believes this will aid the user of the Standard to better understand the subject of Dimensioning and Tolerancing.

Three new terms that are introduced are used only with datums. The terms are "maximum material boundary (MMB)," "least material boundary (LMB)," and "regardless of material boundary (RMB)." These terms better describe that there is a boundary defined when applying datums. MMB and LMB may be a maximum material or least material boundary, respectively, or the applicable virtual condition. The MMB would be an actual maximum material boundary if the tolerance (location or orientation) for that datum feature was zero at MMC. The LMB would be an actual least material boundary if the tolerance (location or orientation) for that datum feature was zero at LMC. In the case of a feature of size as a primary datum feature, the MMB or LMB would be the actual maximum or least material boundary if the form of the feature of size was controlled by Rule #1, or a zero at MMC or LMC straightness of the axis or flatness of the center plane was applied. RMB indicates that the datum features apply at any boundary based on the actual size of the feature and any geometric tolerance applied that together generate a unique boundary.

Since many major industries are becoming more global, resulting in the decentralization of design and manufacturing, it is even more important that the design more precisely state the functional requirements. To accomplish this it is becoming increasingly important that the use of geometric and dimensioning (GD&T) replace the former limit dimensioning for form, orientation, location, and profile of part features. This revision contains paragraphs that give a stronger admonition than in the past that the fully defined drawing should be dimensioned using GD&T with limit dimensioning reserved primarily for the size dimensions for features of size. Additionally, recognizing the need to automate the design, analysis, and measurement processes, and reduce the number of "view dependent tolerances," additional symbology has been introduced for some more common tolerancing practices.

Work on this issue began at a meeting in Sarasota, Florida in January 1994. Numerous deferred comments from the public review for the previous revision, as well as proposals for revision and improvement from the subcommittee and interested parties from the user community, were evaluated at subsequent semi-annual meetings. The subcommittee divided into working groups for several meetings and then reconvened as a subcommittee as a whole to review and ensure the continuity of the revision.

Internationally, a new joint harmonization group formed in January 1993 was called the ISO/TC 3-10-57 JHG. The object was to harmonize the work and principles among ISO/TC3 Surface Texture, ISO/TC 10 SC 5 Dimensioning and Tolerancing, and ISO/TC 57 Measurement. The task of this group was to identify and suggest resolutions to problems among the three disciplines. Many representatives of the ASME Y14.5 subcommittee participated in the meetings of this group from September 1993 through June 1996. In Paris in June 1996 the ISO/TC 3-10-57 JHG became ISO/TC 213, and the responsibilities of the three other ISO committees were transferred to ISO/TC 213. Representatives of the U.S. have participated in all of the ISO/TC 213 meetings from June 1996 through January 1999. Because of difficulties, the U.S. was not represented again until January 2006, and representation is now ongoing.

In the U.S., a similar committee was formed following the formation of ISO/TC 213 as a home for the U.S. TAG (Technical Advisory Group) to ISO/TC 213 and also to serve as an advisory committee to the three U.S. committees and subcommittees that are parallel to the ISO groups (Surface Texture B46, Dimensioning and Tolerancing Y14.5, and Measurement B89). This new committee, called H213, was formed at a meeting in 1997 by representatives of the three U.S. committees or subcommittees. H213 does not have responsibility for all three subjects as does the ISO committee, but rather serves as an intermediary to identify and facilitate a resolution to problems that may exist among the three disciplines as well as the home for the U.S. TAG.



Suggestions for improvement of this Standard are welcome. They should be sent to The American Society of Mechanical Engineers; Attn: Secretary, Y14 Standards Committee; Three Park Avenue, New York, NY 10016.

This revision was approved as an American National Standard on February 6, 2009.

NOTE: The user's attention is called to the possibility that compliance with this Standard may require use of an invention covered by patent rights.

By publication of this Standard, no position is taken with respect to the validity of any such claim(s) or of any patent rights in connection therewith. If a patent holder has filed a statement of willingness to grant a license under these rights on reasonable and nondiscriminatory terms and conditions to applicants desiring to obtain such a license, then details may be obtained from the standards developer.

#### **Acknowledgments**

P. J. McCuiston, Ohio University, created the illustrations for this Standard.

# ASME Y14 COMMITTEE

## Engineering Drawing and Related Documentation Practices

(The following is the roster of the Committee at the time of approval of this Standard.)

### STANDARDS COMMITTEE OFFICERS

F. Bakos, *Chair*  
W. A. Kaba, *Vice Chair*  
C. J. Gomez, *Secretary*

### STANDARDS COMMITTEE PERSONNEL

A. R. Anderson, Dimensional Control Systems, Inc./ Dimensional Dynamics, LLC	W. A. Kaba, Spirit AeroSystems, Inc.
F. Bakos, Consultant	K. S. King, BAE Systems
J. V. Burleigh, Consultant	A. Krulikowski, Effective Training Inc.
D. E. Day, TEC-EASE, Inc.	P. J. McCuistion, Ohio University
K. Dobert, Siemens PLM Software, Inc./Geometric Design Services	J. D. Meadows, James D. Meadows and Associates, Inc.
C. W. Ferguson, WM Education Services	J. M. Smith, Caterpillar, Inc.
C. J. Gomez, The American Society of Mechanical Engineers	N. H. Smith, Spirit AeroSystems, Inc.
B. A. Harding, Purdue University	K. E. Wiegandt, Sandia National Laboratories
D. H. Honsinger, Consultant	R. G. Wilhelm, University of North Carolina
	B. A. Wilson, The Boeing Company

### SUBCOMMITTEE 5 — DIMENSIONING AND TOLERANCING

A. R. Anderson, <i>Chair</i> , Dimensional Control Systems, Inc./ Dimensional Dynamics, LLC.	K. S. King, BAE Systems
F. Bakos, Consultant	A. Krulikowski, Effective Training, Inc.
N. W. Cutler, Dimensional Management, Inc.	P. J. McCuistion, Ohio University
D. E. Day, TEC-EASE, Inc.	M. E. Meloro, <i>Secretary</i> , Northrop Grumman Corp.
K. Dobert, Siemens PLM Software, Inc./Geometric Design Services	T. C. Miller, Los Alamos National Laboratory
P. J. Drake, Jr., MechSigma Consulting, Inc	A. G. Neumann, Technical Consultants, Inc.
C. W. Ferguson, WM Education Service	E. Niemiec, Consultant
C. J. Gomez, <i>Staff Secretary</i> , The American Society of Mechanical Engineers	G. M. Patterson, GE Aircraft Engines
C. Houk, Hamilton Sundstrand Corporation	D. W. Shepherd, Shepherd Industries
D. P. Karl, <i>Vice Chair</i> , Karl Engineering Services Inc.	J. M. Smith, Caterpillar, Inc.
J. D. Keith, Spirit Aero Systems, Inc.	B. A. Wilson, The Boeing Company
	M. P. Wright, Lockheed Martin Aeronautics Co.

### SUBCOMMITTEE 5 — SUPPORT GROUP

O. J. Deschepper, General Motors	J. I. Miles, Lockheed Martin Aeronautics
B. R. Fischer, Advanced Dimensional Management, LLC	M. A. Murphy, General Motors Corporation
B. A. Harding, Purdue University	R. A. Wheeler, Goodrich Aerostructures
D. H. Honsinger, Consultant	R. D. Wiles, Datum Inspection Services
P. Mares, The Boeing Company	J. E. Winconek, Consultant
J. D. Meadows, James D. Meadows and Associates, Inc.	

# CORRESPONDENCE WITH THE Y14 COMMITTEE

**General.** ASME Standards are developed and maintained with the intent to represent the consensus of concerned interests. As such, users of this Standard may interact with the Committee by proposing revisions and attending Committee meetings. Correspondence should be addressed to:

Secretary, Y14 Standards Committee  
The American Society of Mechanical Engineers  
Three Park Avenue  
New York, NY 10016-5990

**Proposing Revisions.** Revisions are made periodically to the Standard to incorporate changes that appear necessary or desirable, as demonstrated by the experience gained from the application of the Standard. Approved revisions will be published periodically.

The Committee welcomes proposals for revisions to this Standard. Such proposals should be as specific as possible, citing the paragraph number(s), the proposed wording, and a detailed description of the reasons for the proposal including any pertinent documentation.

**Proposing a Case.** Cases may be issued for the purpose of providing alternative rules when justified, to permit early implementation of an approved revision when the need is urgent, or to provide rules not covered by existing provisions. Cases are effective immediately upon ASME approval and shall be posted on the ASME Committee Web page.

Requests for Cases shall provide a Statement of Need and Background Information. The request should identify the standard, the paragraph, figure or table number(s), and be written as a Question and Reply in the same format as existing Cases. Requests for Cases should also indicate the applicable edition(s) of the standard to which the proposed Case applies.

**Attending Committee Meetings.** The Y14 Standards Committee regularly holds meetings or telephone conferences, which are open to the public. Persons wishing to attend any meeting or telephone conference should contact the Secretary of the Y14 Standards Committee or check our Web site at <http://cstools.asme.org/csconnect/>.

**INTENTIONALLY LEFT BLANK**

X

# DIMENSIONING AND TOLERANCING

## Section 1 Scope, Definitions, and General Dimensioning

### 1.1 SCOPE

This Standard establishes uniform practices for stating and interpreting dimensioning, tolerancing, and related requirements for use on engineering drawings and in related documents. For a mathematical explanation of many of the principles in this Standard, see ASME Y14.5.1. Practices unique to architectural and civil engineering and welding symbology are not included.

#### 1.1.1 General

Section 1 establishes definitions, fundamental rules, and practices for general dimensioning. For tolerancing practices, see Sections 2 through 9. Additional information about tolerancing maybe found in Nonmandatory Appendices A through E.

#### 1.1.2 Units

The International System of Units (SI) is featured in this Standard because SI units are expected to supersede United States (U.S.) customary units specified on engineering drawings. Customary units could equally well have been used without prejudice to the principles established.

#### 1.1.3 Reference to This Standard

Where drawings are based on this Standard, this fact shall be noted on the drawings or in a document referenced on the drawings. References to this Standard shall state ASME Y14.5-2009.

#### 1.1.4 Figures

The figures in this Standard are intended only as illustrations to aid the user in understanding the principles and methods of dimensioning and tolerancing described in the text. The absence of a figure illustrating the desired application is neither reason to assume inapplicability, nor basis for drawing rejection. In some instances, figures show added detail for emphasis. In other instances, figures are incomplete by intent. Numerical values of dimensions and tolerances are illustrative only. Multiview drawings contained within figures are third angle projection.

NOTE: To assist the users of this Standard, a listing of the paragraph(s) that refer to an illustration appears in the lower right-hand corner of each figure. This listing may not be all-inclusive. The absence of a listing is not a reason to assume inapplicability. Some illustrations may diverge from Y14 drawing practices to clarify the meanings of principles.

#### 1.1.5 Notes

Notes herein in capital letters are intended to appear on finished drawings. Notes in lowercase letters are explanatory only and are not intended to appear on drawings.

#### 1.1.6 Reference to Gaging

This document is not intended as a gaging standard. Any reference to gaging is included for explanatory purposes only. For gaging principles see ASME Y14.43 Dimensioning and Tolerancing Principles for Gages and Fixtures.

#### 1.1.7 Symbols

Adoption of symbols indicating dimensional requirements, as shown in Fig. C-2 of Nonmandatory Appendix C, does not preclude the use of equivalent terms or abbreviations where symbology is considered inappropriate.

### 1.2 REFERENCES

The following revisions of American National Standards form a part of this Standard to the extent specified herein. A more recent revision may be used provided there is no conflict with the text of this Standard. In the event of a conflict between the text of this Standard and the references cited herein, the text of this Standard shall take precedence.

#### 1.2.1 Cited Standards

- ANSI/ASME B89.6.2-1973 (R2003), Temperature and Humidity Environment for Dimensional Measurement
- ANSI/ASME B94.6-1984 (R2003), Knurling
- ANSI B4.2-1978 (R2004), Preferred Metric Limits and Fits

ANSI B89.3.1-1972 (R2003), Measurement of Out-of-Roundness

ANSI B92.1-1996,1 Involute Splines and Inspection, Inch Version

ANSI B92.2M-1980,1 Metric Module, Involute Splines

ANSI Y14.6-2001 (R2007), Screw Thread Representation

ANSI Y14.6aM-1981 (R1998), Screw Thread Representation (Metric Supplement)

Publisher: American National Standards Institute (ANSI), 25 West 43rd Street, New York, NY 10036

ASME B5.10-1994, Machine Tapers — Self Holding and Steep Taper Series

ASME B46.1-2002, Surface Texture, Surface Roughness, Waviness, and Lay

ASME B94.11M-1993, Twist Drills

ASME Y14.1-2005, Drawing Sheet Size and Format

ASME Y14.1M-2005, Metric Drawing Sheet Size and Format

ASME Y14.2-2008, Line Conventions and Lettering

ASME Y14.5.1M-1994 (R2004), Mathematical Definition of Dimensioning and Tolerancing Principles

ASME Y14.8-2009, Castings and Forgings

ASME Y14.36M-1996 (R2008), Surface Texture Symbols

ASME Y14.41-2003 (R2008), Digital Product Definition Data Practices

ASME Y14.43-2003 (R2008), Dimensioning and Tolerancing Principles for Gages and Fixtures

Publisher: The American Society of Mechanical Engineers (ASME), Three Park Avenue, New York, NY 10016; Order Department: 22 Law Drive, P.O. Box 2300, Fairfield, NJ 07007-2300

IEEE/ASTM SI 10-2002 ERRATA 2005, Standard for Use of the International System of Units (SI) — The Modern Metric System

Publisher: Institute of Electrical and Electronics Engineers (IEEE), 445 Hoes Lane, Piscataway, NJ 08854

### 1.2.2 Additional Sources (Not Cited)

ANSI/ASME B1.2-1983 (R2007), Gages and Gaging for Unified Inch Screw Threads

ANSI B4.4M-1981, Inspection of Workpieces

Publisher: American National Standards Institute (ANSI), 25 West 43rd Street, New York, NY 10036

ASME Y14.3M-2003 (R2008), Multiview and Sectional View Drawings

ASME Y14.38M-2007, Abbreviations

ASME Y14.100-2004, Engineering Drawing Practices

Publisher: The American Society of Mechanical Engineers (ASME), Three Park Avenue, New York, NY 10016; Order Department: 22 Law Drive, P.O. Box 2300, Fairfield, NJ 07007-2300

## 1.3 DEFINITIONS

The following terms are defined as their use applies in this Standard. Additionally, definitions throughout the Standard of italicized terms are given in sections describing their application. Their location may be identified by referring to the index.

### 1.3.1 Angularity

*angularity*: see para. 6.3.1.

### 1.3.2 Boundary, Inner

*boundary, inner*: a worst-case boundary generated by the smallest feature (MMC for an internal feature and LMC for an external feature) minus the stated geometric tolerance and any additional geometric tolerance (if applicable) resulting from the feature's departure from its specified material condition. See Figs. 2-12 through 2-17.

### 1.3.3 Boundary, Least Material (LMB)

*boundary, least material (LMB)*: the limit defined by a tolerance or combination of tolerances that exists on or inside the material of a feature(s).

### 1.3.4 Boundary, Maximum Material (MMB)

*boundary, maximum material (MMB)*: the limit defined by a tolerance or combination of tolerances that exists on or outside the material of a feature(s).

### 1.3.5 Boundary, Outer

*boundary, outer*: a worst-case boundary generated by the largest feature (LMC for an internal feature and MMC for an external feature) plus the stated geometric tolerance and any additional geometric tolerance (if applicable) resulting from the feature's departure from its specified material condition. See Figs. 2-12 through 2-17.

### 1.3.6 Circularity (Roundness)

*circularity (roundness)*: see para. 5.4.3.

### 1.3.7 Coaxiality

*coaxiality*: see para. 7.6.

### 1.3.8 Complex Feature

*complex feature*: a single surface of compound curvature or a collection of other features that constrains up to six degrees of freedom.

### 1.3.9 Concentricity

*concentricity*: see para. 7.6.4.

### 1.3.10 Coplanarity

*coplanarity*: see para. 8.4.1.1.

### 1.3.11 Constraint

*constraint*: a limit to one or more degrees of freedom.

### 1.3.12 Cylindricity

*cylindricity*: see para. 5.4.4.

### 1.3.13 Datum

*datum*: a theoretically exact point, axis, line, plane, or combination thereof derived from the theoretical datum feature simulator.

### 1.3.14 Datum Axis

*datum axis*: the axis of a datum feature simulator established from the datum feature.

### 1.3.15 Datum Center Plane

*datum center plane*: the center plane of a datum feature simulator established from the datum feature.

### 1.3.16 Datum Feature

*datum feature*: a feature that is identified with either a datum feature symbol or a datum target symbol.

### 1.3.17 Datum Feature Simulator

*datum feature simulator*: encompasses two types: theoretical and physical. See paras. 1.3.17.1 and 1.3.17.2.

**1.3.17.1 Datum Feature Simulator (Theoretical).** *datum feature simulator (theoretical)*: the theoretically perfect boundary used to establish a datum from a specified datum feature.

NOTE: Whenever the term “datum feature simulator” is used in this Standard, it refers to the theoretical, unless specifically otherwise indicated.

**1.3.17.2 Datum Feature Simulator (Physical).** *datum feature simulator (physical)*: the physical boundary used to establish a simulated datum from a specified datum feature.

NOTE: For example, a gage, fixture element, or digital data (such as machine tables, surface plates, a mandrel, or mathematical simulation) —although not true planes — are of sufficient quality that the planes derived from them are used to establish simulated datums. Physical datum feature simulators are used as the physical embodiment of the theoretical datum feature simulators during manufacturing and inspection. See ASME Y14.43.

### 1.3.18 Datum Reference Frame

*datum reference frame*: see para. 4.1.

### 1.3.19 Datum, Simulated

*datum, simulated*: a point, axis, line, or plane (or combination thereof) coincident with or derived from processing or inspection equipment, such as the following simulators: a surface plate, a gage surface, a mandrel, or mathematical simulation. See para. 4.6.

### 1.3.20 Datum Target

*datum target*: see para. 4.24.

### 1.3.21 Diameter, Average

*diameter, average*: see para. 5.5.3.

### 1.3.22 Dimension

*dimension*: a numerical value(s) or mathematical expression in appropriate units of measure used to define the form, size, orientation or location, of a part or feature.

### 1.3.23 Dimension, Basic

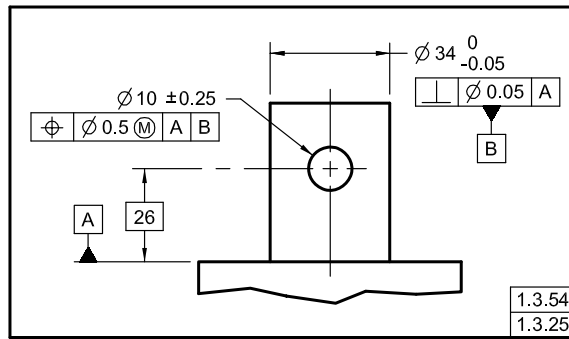
*dimension, basic*: a theoretically exact dimension.

NOTE: A basic dimension is indicated by one of the methods shown in Figs. 3-10 and 7-1.

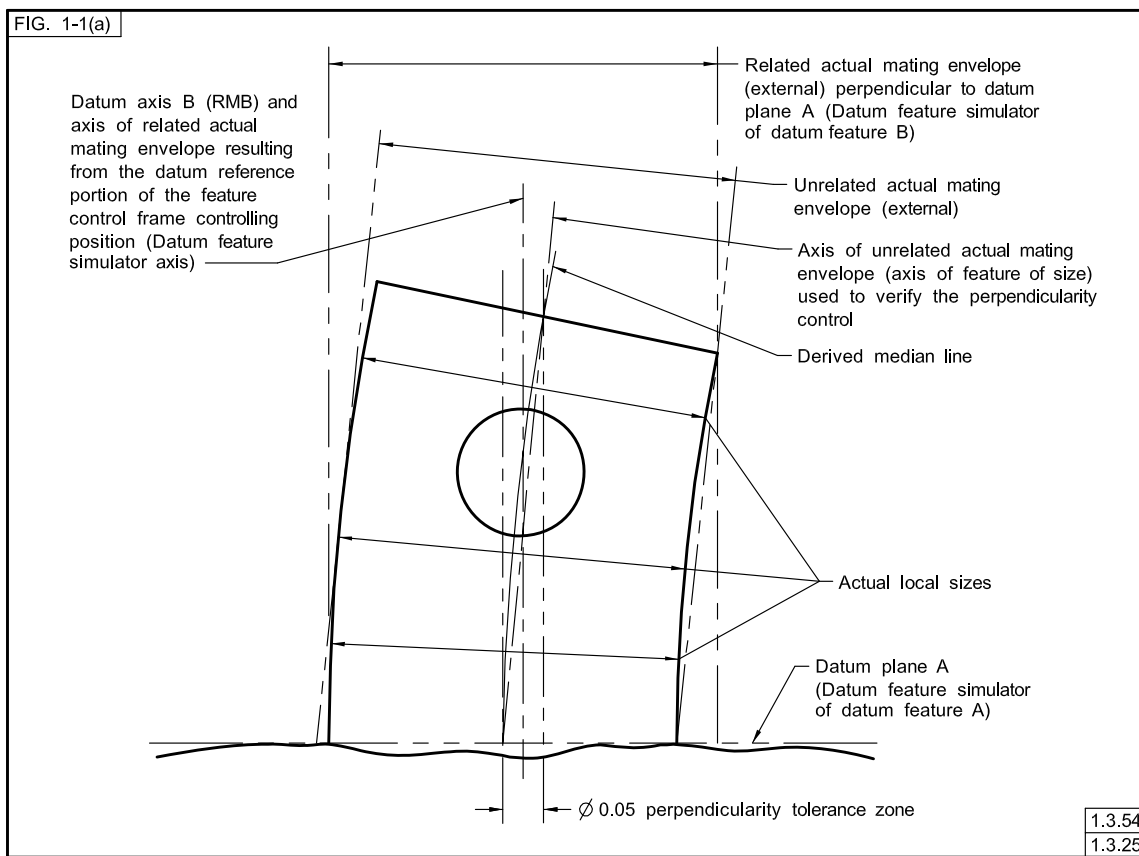
### 1.3.24 Dimension, Reference

*dimension, reference*: a dimension, usually without a tolerance, that is used for informational purposes only.

**Fig. 1-1 Related and Unrelated Actual Mating Envelope**



**Fig. 1-1 Related and Unrelated Actual Mating Envelope (Cont'd)**



NOTE: A reference dimension is a repeat of a dimension or is derived from other values shown on the drawing or on related drawings. It is considered auxiliary information and does not govern production or inspection operations. See Figs. 1-19 and 1-20. Where a basic dimension is repeated on a drawing, it need not be identified as reference. For information on how to indicate a reference dimension, see para 1.7.6.

**1.3.25 Envelope, Actual Mating**

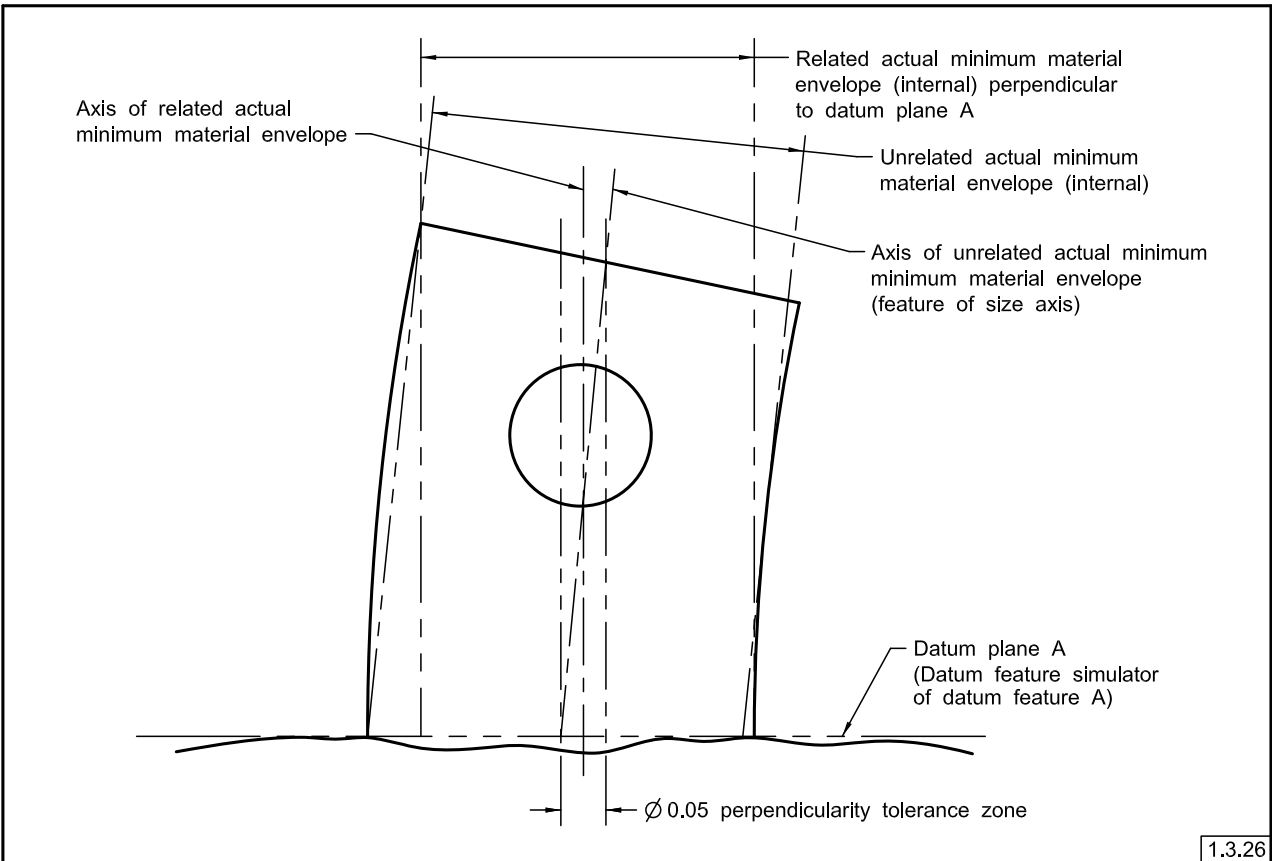
*envelope, actual mating:* this envelope is outside the material. A similar perfect feature(s) counterpart of

smallest size that can be contracted about an external feature(s) or largest size that can be expanded within an internal feature(s) so that it coincides with the surface(s) at the highest points. Two types of actual mating envelopes — unrelated and related — are described in paras. 1.3.25.1 and 1.3.25.2.

**1.3.25.1 Unrelated Actual Mating Envelope.** *unrelated actual mating envelope:* a similar perfect feature(s) counterpart expanded within an internal feature(s) or contracted about an external feature(s), and not constrained to any datum(s). See Fig. 1-1.



Fig. 1-2 Related and Unrelated Actual Minimum Envelope From Figure 1-1



**1.3.25.2 Related Actual Mating Envelope.** *related actual mating envelope*: a similar perfect feature counterpart expanded within an internal feature(s) or contracted about an external feature(s) while constrained either in orientation or location or both to the applicable datum(s). See Fig. 1-1.

### 1.3.26 Envelope, Actual Minimum Material

*envelope, actual minimum material*: this envelope is within the material. A similar perfect feature(s) counterpart of largest size that can be expanded within an external feature(s) or smallest size that can be contracted about an internal feature(s) so that it coincides with the surface(s) at the lowest points. Two types of actual minimum material envelopes — unrelated and related — are described in paras. 1.3.26.1 and 1.3.26.2.

**1.3.26.1 Unrelated Actual Minimum Material Envelope.** *unrelated actual minimum material envelope*: a similar perfect feature(s) counterpart contracted about an internal feature(s) or expanded within an external feature(s), and not constrained to any datum reference frame. See Fig. 1-2.

**1.3.26.2 Related Actual Minimum Material Envelope.** *related actual minimum material envelope*: a similar perfect feature(s) counterpart contracted about an internal feature(s) or expanded within an external feature(s) while constrained in either orientation or location or both to the applicable datum(s). See Fig. 1-2.

### 1.3.27 Feature

*feature*: a physical portion of a part such as a surface, pin, hole, or slot or its representation on drawings, models, or digital data files.

### 1.3.28 Feature Axis

*feature axis*: the axis of the unrelated actual mating envelope of a feature.

NOTE: In this Standard, when the term “feature axis” is used, it refers to the axis of the unrelated actual mating envelope unless specified otherwise.

### 1.3.29 Feature, Center Plane of

*feature, center plane of*: the center plane of the unrelated actual mating envelope of a feature.

NOTE: In this Standard, when the term “feature center plane” is used, it refers to the center plane of the unrelated actual mating envelope unless specified otherwise.

### 1.3.30 Derived Median Plane

*derived median plane*: an imperfect (abstract) plane formed by the center points of all line segments bounded by the feature. These line segments are normal (perpendicular) to the center plane of the unrelated actual mating envelope.

### 1.3.31 Derived Median Line

*derived median line*: an imperfect (abstract) line formed by the center points of all cross sections of the feature. These cross sections are normal (perpendicular) to the axis of the unrelated actual mating envelope.

### 1.3.32 Feature of Size

*feature of size*: encompasses two types: regular and irregular. See paras. 1.3.32.1 and 1.3.32.2.

**1.3.32.1 Regular Feature of Size.** *regular feature of size*: one cylindrical or spherical surface, a circular element, and a set of two opposed parallel elements or opposed parallel surfaces, each of which is associated with a directly toleranced dimension. See para. 2.2.

**1.3.32.2 Irregular Feature of Size.** *irregular feature of size*: the two types of irregular features of size are as follows:

(a) a directly toleranced feature or collection of features that may contain or be contained by an actual mating envelope that is a sphere, cylinder, or pair of parallel planes

(b) a directly toleranced feature or collection of features that may contain or be contained by an actual mating envelope other than a sphere, cylinder, or pair of parallel planes

### 1.3.33 Feature Control Frame

*feature control frame*: see para. 3.4.1.

### 1.3.34 Feature-Relating Tolerance Zone Framework (FRTZF)

*feature-relating tolerance zone framework (FRTZF)*: the tolerance zone framework(s) that controls the basic relationship between the features in a pattern with that framework constrained in rotational degrees of freedom relative to any referenced datum features.

### 1.3.35 Free State

*free state*: the condition of a part free of applied forces.

### 1.3.36 Free-State Variation

*free-state variation*: see para. 5.5.

### 1.3.37 Flatness

*flatness*: see para. 5.4.2.

### 1.3.38 Least Material Condition (LMC)

*least material condition (LMC)*: the condition in which a feature of size contains the least amount of material within the stated limits of size (e.g., maximum hole diameter, minimum shaft diameter).

### 1.3.39 Maximum Material Condition (MMC)

*maximum material condition (MMC)*: the condition in which a feature of size contains the maximum amount of material within the stated limits of size (e.g., minimum hole diameter, maximum shaft diameter).

### 1.3.40 Non-Uniform Tolerance Zone

*non-uniform tolerance zone*: see para. 8.3.2.

### 1.3.41 Parallelism

*parallelism*: see para. 6.3.2.

### 1.3.42 Pattern

*pattern*: two or more features or features of size to which a locational geometric tolerance is applied and are grouped by one of the following methods: nX, n COAXIAL HOLES, ALL OVER, A ↔ B, n SURFACES, simultaneous requirements, or INDICATED.

### 1.3.43 Pattern-Locating Tolerance Zone Framework (PLTZF)

*pattern-locating tolerance zone framework (PLTZF)*: the tolerance zone framework that controls the basic relationship between the features in a pattern with that framework constrained in translational and rotational degrees of freedom relative to the referenced datum features.

### 1.3.44 Perpendicularity

*perpendicularity*: see para. 6.3.3.

### 1.3.45 Plane, Tangent

*plane, tangent*: a plane that contacts the high points of the specified feature surface.

### 1.3.46 Position

*position*: see para. 7.2.

**1.3.47 Profile**

*profile*: see para. 8.2

**1.3.48 Regardless of Feature Size (RFS)**

*regardless of feature size (RFS)*: indicates a geometric tolerance applies at any increment of size of the actual mating envelope of the feature of size.

**1.3.49 Regardless of Material Boundary (RMB)**

*regardless of material boundary (RMB)*: indicates that a datum feature simulator progresses from MMB toward LMB until it makes maximum contact with the extremities of a feature(s).

**1.3.50 Restraint**

*restraint*: the application of force(s) to a part to simulate its assembly or functional condition resulting in possible distortion of a part from its free-state condition. See para. 4.20.

**1.3.51 Resultant Condition**

*resultant condition*: the single worst-case boundary generated by the collective effects of a feature of the size's specified MMC or LMC, the geometric tolerance for that material condition, the size tolerance, and the additional geometric tolerance derived from the feature's departure from its specified material condition. See Figs. 2-12, 2-13, 2-15, and 2-16.

**1.3.52 Runout**

*runout*: see para. 9.2.

**1.3.53 Simultaneous Requirement**

*simultaneous requirement*: see para. 4.19.

**1.3.54 Size, Actual Local**

*size, actual local*: the measured value of any individual distance at any cross section of a feature of size. See Fig. 1-1.

**1.3.55 Size, Limits of**

*size, limits of*: the specified maximum and minimum sizes. See para. 2.7.

**1.3.56 Size, Nominal**

*size, nominal*: the designation used for purposes of general identification.

**1.3.57 Straightness**

*straightness*: see para. 5.4.1.

**1.3.58 Statistical Tolerancing**

*statistical tolerancing*: see para. 2.17.

**1.3.59 Symmetry**

*symmetry*: see para. 7.7.2.

**1.3.60 Tolerance**

*tolerance*: the total amount a specific dimension is permitted to vary. The tolerance is the difference between the maximum and minimum limits.

**1.3.61 Tolerance, Bilateral**

*tolerance, bilateral*: a tolerance in which variation is permitted in both directions from the specified dimension.

**1.3.62 Tolerance, Geometric**

*tolerance, geometric*: the general term applied to the category of tolerances used to control size, form, profile, orientation, location, and runout.

**1.3.63 Tolerance, Unilateral**

*tolerance, unilateral*: a tolerance in which variation is permitted in one direction from the specified dimension.

**1.3.64 True Position**

*true position*: the theoretically exact location of a feature of size, as established by basic dimensions.

**1.3.65 True Profile**

*true profile*: see para. 8.2.

**1.3.66 Uniform Tolerance Zone**

*uniform tolerance zone*: see para. 8.3.1.

**1.3.67 Virtual Condition**

*virtual condition*: a constant boundary generated by the collective effects of a considered feature of the size's specified MMC or LMC and the geometric tolerance for that material condition. See Figs. 2-12, 2-13, 2-15, and 2-16.

**1.4 FUNDAMENTAL RULES**

Dimensioning and tolerancing shall clearly define engineering intent and shall conform to the following.

(a) Each dimension shall have a tolerance, except for those dimensions specifically identified as reference, maximum, minimum, or stock (commercial stock size). The tolerance may be applied directly to the dimension (or indirectly in the case of basic dimensions), indicated by a general note, or located in a supplementary block of the drawing format. See ASME Y14.1 and ASME Y14.1M.

(b) Dimensioning and tolerancing shall be complete so there is full understanding of the characteristics of each feature. Values may be expressed in an engineering drawing or in a CAD product definition data set. See ASME Y14.41. Neither scaling (measuring directly from an engineering drawing) nor assumption of a distance or size is permitted, except as follows: undimensioned drawings, such as loft, printed wiring, templates, and master layouts prepared on stable material, provided the necessary control dimensions are specified.

(c) Each necessary dimension of an end product shall be shown. No more dimensions than those necessary for complete definition shall be given. The use of reference dimensions on a drawing should be minimized.

(d) Dimensions shall be selected and arranged to suit the function and mating relationship of a part and shall not be subject to more than one interpretation.

(e) The drawing should define a part without specifying manufacturing methods. Thus, only the diameter of a hole is given without indicating whether it is to be drilled, reamed, punched, or made by any other operation. However, in those instances where manufacturing, processing, quality assurance, or environmental information is essential to the definition of engineering requirements, it shall be specified on the drawing or in a document referenced on the drawing.

(f) Nonmandatory processing dimensions shall be identified by an appropriate note, such as “NONMANDATORY (MFG DATA).” Examples of nonmandatory data are processing dimensions that provide for finish allowance, shrink allowance, and other requirements, provided the final dimensions are given on the drawing.

(g) Dimensions should be arranged to provide required information for optimum readability. Dimensions should be shown in true profile views and refer to visible outlines.

(h) Wires, cables, sheets, rods, and other materials manufactured to gage or code numbers shall be specified by linear dimensions indicating the diameter or thickness. Gage or code numbers may be shown in parentheses following the dimension.

(i) A 90° angle applies where center lines and lines depicting features are shown on a 2D orthographic drawing at right angles and no angle is specified. See para. 2.1.1.3.

(j) A 90° basic angle applies where center lines of features in a pattern or surfaces shown at right angles on a 2D orthographic drawing are located or defined by basic dimensions and no angle is specified. See para. 2.1.1.4.

(k) A zero basic dimension applies where axes, center planes, or surfaces are shown coincident on a drawing, and geometric tolerances establish the relationship among the features. See para. 2.1.1.4.

(l) Unless otherwise specified, all dimensions and tolerances are applicable at 20°C (68°F) in accordance with ANSI/ASME B89.6.2. Compensation may be made for measurements made at other temperatures.

(m) Unless otherwise specified, all dimensions and tolerances apply in a free-state condition. For exceptions to this rule see paras. 4.20 and 5.5.

(n) Unless otherwise specified, all tolerances apply for full depth, length, and width of the feature.

(o) Dimensions and tolerances apply only at the drawing level where they are specified. A dimension specified for a given feature on one level of drawing (e.g., a detail drawing) is not mandatory for that feature at any other level (e.g., an assembly drawing).

(p) Where a coordinate system is shown on the drawing, it shall be right-handed unless otherwise specified. Each axis shall be labeled and the positive direction shall be shown.

NOTE: Where a model coordinate system is shown on the drawing, it shall be in compliance with ASME Y14.41.

## 1.5 UNITS OF MEASURE

For uniformity, all dimensions in this Standard are given in SI units. However, the unit of measure selected should be in accordance with the policy of the user.

### 1.5.1 SI (Metric) Linear Units

The SI linear unit commonly used on engineering drawings is the millimeter.

### 1.5.2 U.S. Customary Linear Units

The U.S. Customary linear unit commonly used on engineering drawings is the decimal inch.

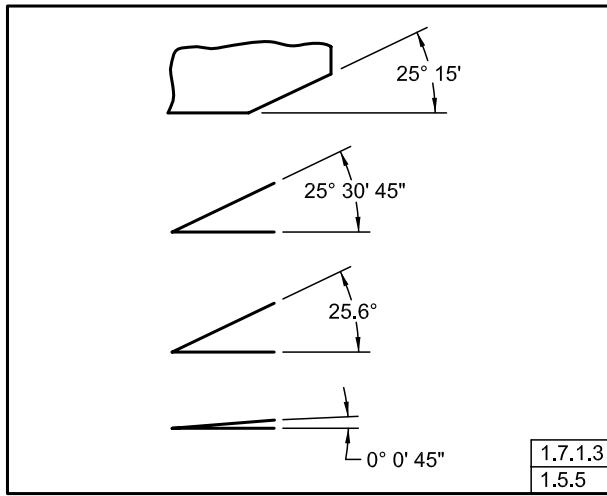
### 1.5.3 Identification of Linear Units

On drawings where all dimensions are in millimeters or all dimensions are in inches, individual identification of linear units is not required. However, the drawing shall contain a note stating “UNLESS OTHERWISE SPECIFIED, ALL DIMENSIONS ARE IN MILLIMETERS (or IN INCHES, as applicable).”

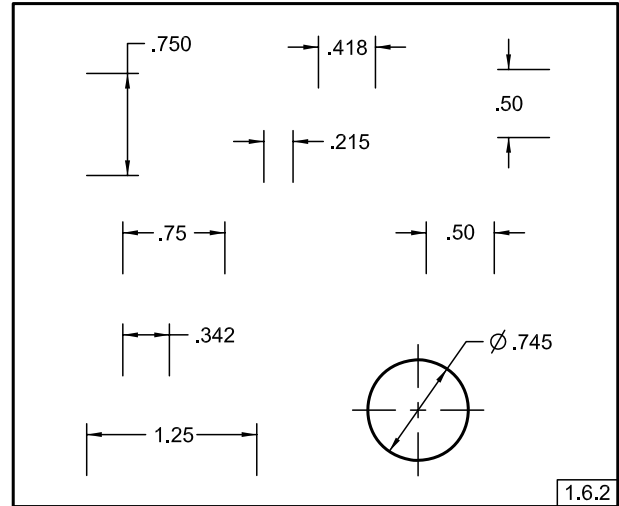
### 1.5.4 Combination SI (Metric) and U.S. Customary Linear Units

Where some inch dimensions are shown on a millimeter-dimensioned drawing, the abbreviation IN shall follow the inch values. Where some millimeter dimensions are shown on an inch-dimensioned drawing, the symbol mm shall follow the millimeter values.

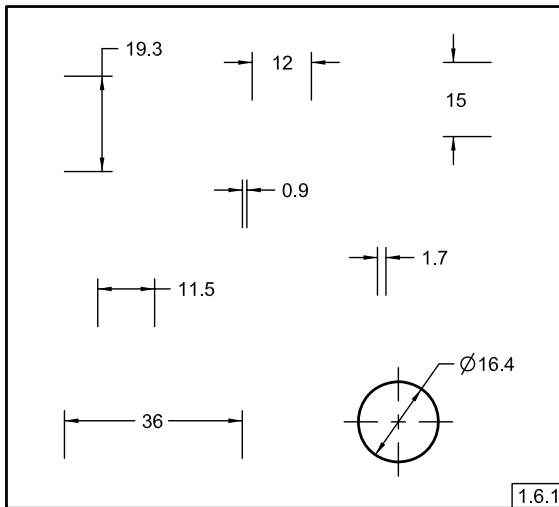
**Fig. 1-3 Angular Units**



**Fig. 1-5 Decimal Inch Dimensions**



**Fig. 1-4 Millimeter Dimensions**



**1.5.5 Angular Units**

Angular dimensions are expressed in both degrees and decimal parts of a degree or in degrees, minutes, and seconds. These latter dimensions are expressed by the following symbols:

- (a) degrees: °
- (b) minutes: '
- (c) seconds: ''

Where degrees are indicated alone, the numerical value shall be followed by the symbol. Where only minutes or seconds are specified, the number of minutes or seconds shall be preceded by 0° or 0°0', as applicable. Where decimal degrees less than one are specified, a zero shall precede the decimal value. See Fig. 1-3.

**1.6 TYPES OF DIMENSIONING**

Decimal dimensioning shall be used on drawings except where certain commercial commodities are identified by standardized nominal size designations, such as pipe and lumber sizes.

**1.6.1 Millimeter Dimensioning**

The following shall be observed where specifying millimeter dimensions on drawings:

- (a) Where the dimension is less than one millimeter, a zero precedes the decimal point. See Fig. 1-4.
- (b) Where the dimension is a whole number, neither the decimal point nor a zero is shown. See Fig. 1-4.
- (c) Where the dimension exceeds a whole number by a decimal fraction of one millimeter, the last digit to the right of the decimal point is not followed by a zero. See Fig. 1-4.

NOTE: This practice differs for tolerances expressed bilaterally or as limits. See paras. 2.3.1(b) and (c).

- (d) Neither commas nor spaces shall be used to separate digits into groups in specifying millimeter dimensions on drawings.

**1.6.2 Decimal Inch Dimensioning**

The following shall be observed where specifying decimal inch dimensions on drawings:

- (a) A zero is not used before the decimal point for values less than 1 in.
- (b) A dimension is expressed to the same number of decimal places as its tolerance. Zeros are added to the right of the decimal point where necessary. See Fig. 1-5 and para. 2.3.2.

Fig. 1-6 Application of Dimensions

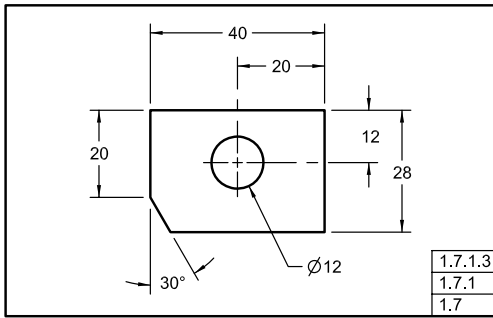


Fig. 1-8 Spacing of Dimension Lines

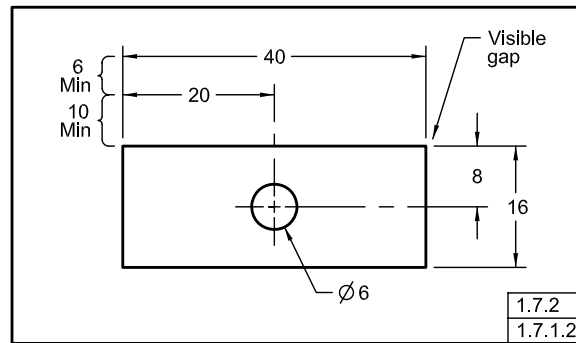


Fig. 1-7 Grouping of Dimensions

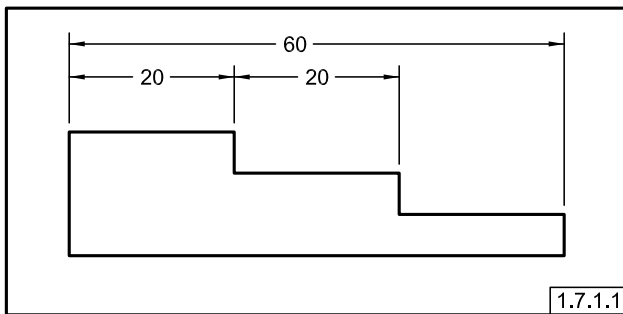
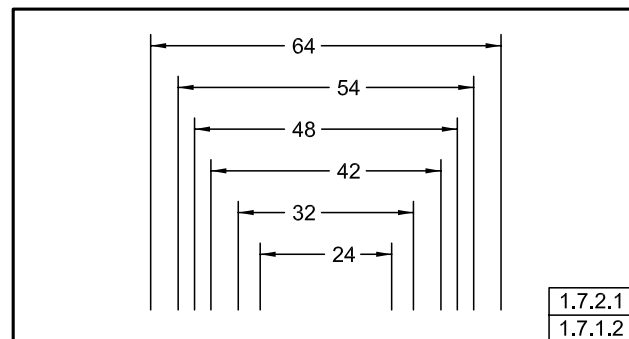


Fig. 1-9 Staggered Dimensions



### 1.6.3 Decimal Points

Decimal points must be uniform, dense, and large enough to be clearly visible and meet the reproduction requirements of ASME Y14.2M. Decimal points are placed in line with the bottom of the associated digits.

### 1.6.4 Conversion and Rounding of Linear Units

For information on conversion and rounding of U.S. Customary linear units, see IEEE/ASTM SI 10.

## 1.7 APPLICATION OF DIMENSIONS

Dimensions are applied by means of dimension lines, extension lines, chain lines, or a leader from a dimension, note, or specification directed to the appropriate feature. See Fig. 1-6. General notes are used to convey additional information. For further information on dimension lines, extension lines, chain lines, and leaders, see ASME Y14.2.

### 1.7.1 Dimension Lines

A dimension line, with its arrowheads, shows the direction and extent of a dimension. Numerals indicate the number of units of a measurement. Preferably, dimension lines should be broken for insertion of numerals as

shown in Fig. 1-6. Where horizontal dimension lines are not broken, numerals are placed above and parallel to the dimension lines.

NOTE: The following shall not be used as a dimension line: a center line, an extension line, a phantom line, a line that is part of the outline of the object, or a continuation of any of these lines. A dimension line is not used as an extension line, except where a simplified method of coordinate dimensioning is used to define curved outlines. See Fig. 1-35

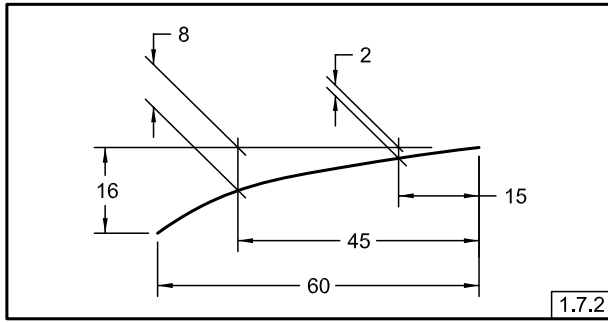
**1.7.1.1 Alignment.** Dimension lines shall be aligned if practicable and grouped for uniform appearance. See Fig. 1-7.

**1.7.1.2 Spacing.** Dimension lines are drawn parallel to the direction of measurement. The space between the first dimension line and the part outline should be not less than 10 mm; the space between succeeding parallel dimension lines should be not less than 6 mm. See Fig. 1-8.

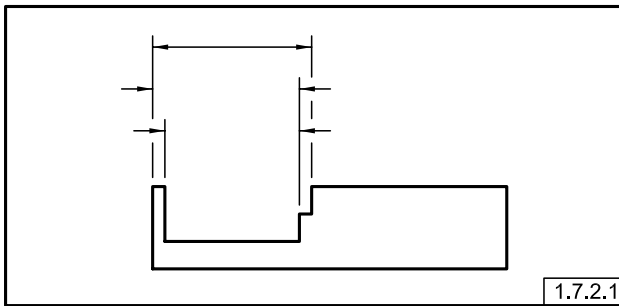
NOTE: These spacings are intended as guides only. If the drawing meets the reproduction requirements of the accepted industry or military reproduction specification, nonconformance to these spacing requirements is not a basis for rejection of the drawing.

Where there are several parallel dimension lines, the numerals should be staggered for easier reading. See Fig. 1-9.

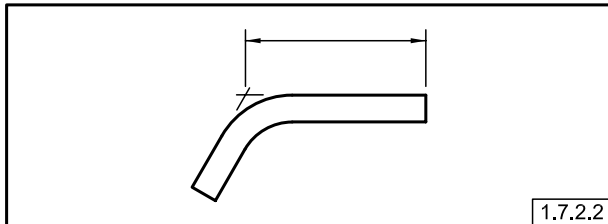
**Fig. 1-10 Oblique Extension Lines**



**Fig. 1-11 Breaks in Extension Lines**



**Fig. 1-12 Point Locations**



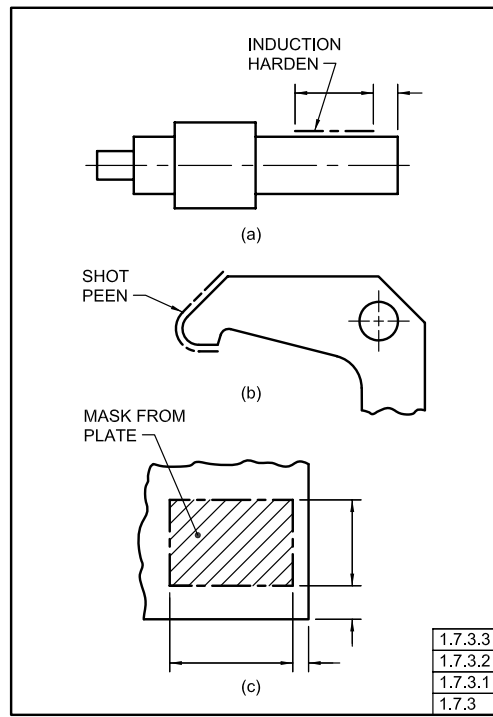
**1.7.1.3 Angle Dimensions.** The dimension line of an angle is an arc drawn with its center at the apex of the angle. The arrowheads terminate at the extensions of the two sides. See Figs. 1-3 and 1-6.

**1.7.1.4 Crossing Dimension Lines.** Crossing dimension lines should be avoided. Where unavoidable, the dimension lines are unbroken.

**1.7.2 Extension (Projection) Lines**

Extension lines are used to indicate the extension of a surface or point to a location preferably outside the part outline. See para. 1.7.8. On 2D orthographic drawings, extension lines start with a short visible gap from the outline of the part and extend beyond the outermost related dimension line. See Fig. 1-8. Extension lines are drawn

**Fig. 1-13 Limited Length or Area Indication**



perpendicular to dimension lines. Where space is limited, extension lines may be drawn at an oblique angle to clearly illustrate where they apply. Where oblique lines are used, the dimension lines are shown in the direction in which they apply. See Fig. 1-10.

**1.7.2.1 Crossing Extension Lines.** Wherever practicable, extension lines should neither cross one another nor cross dimension lines. To minimize such crossings, the shortest dimension line is shown nearest the outline of the object. See Fig. 1-9. Where extension lines must cross other extension lines, dimension lines, or lines depicting features, they are not broken. Where extension lines cross arrowheads or dimension lines close to arrowheads, a break in the extension line is permissible. See Fig. 1-11.

**1.7.2.2 Locating Points or Intersections.** Where a point is located by extension lines only, the extension lines from surfaces should pass through the point or intersection. See Fig. 1-12.

**1.7.3 Limited Length or Area Indication**

Where it is desired to indicate that a limited length or area of a surface is to receive additional treatment or consideration within limits specified on the drawing, the extent of these limits may be indicated by use of a chain line. See Fig. 1-13.

Fig. 1-14 Leaders

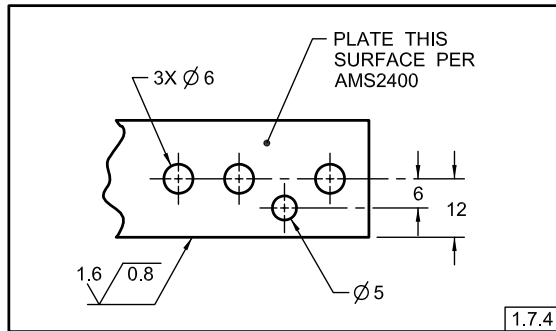
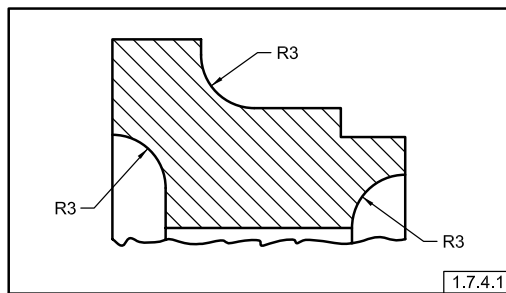


Fig. 1-15 Leader-Directed Dimensions



**1.7.3.1 Chain Lines.** In an appropriate view or section, a chain line is drawn parallel to the surface profile at a short distance from it. Dimensions are added for length and location. If applied to a surface of revolution, the indication may be shown on one side only. See Fig. 1-13, illustration (a).

**1.7.3.2 Omitting Chain Line Dimensions.** If the chain line clearly indicates the location and extent of the surface area, dimensions may be omitted. See Fig. 1-13, illustration (b).

**1.7.3.3 Area Indication Identification.** Where the desired area is shown on a direct view of the surface, the area is section lined within the chain line boundary and appropriately dimensioned. See Fig. 1-13, illustration (c).

## 1.7.4 Leaders (Leader Lines)

A leader is used to direct a dimension, note, or symbol to the intended place on the drawing. Normally, a leader terminates in an arrowhead. However, where it is intended for a leader to refer to a surface by ending within the outline of that surface, the leader should terminate in a dot. A leader should be an inclined straight line except for a short horizontal portion extending to the mid-height of the first or last letter or digit of the note or dimension. Two or more leaders to adjacent areas on the drawing should be drawn parallel to each other. See Fig. 1-14.

Fig. 1-16 Minimizing Leaders

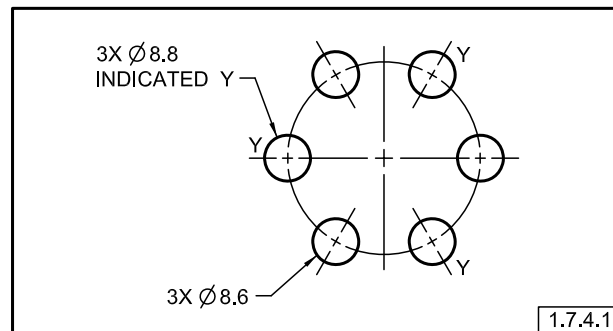
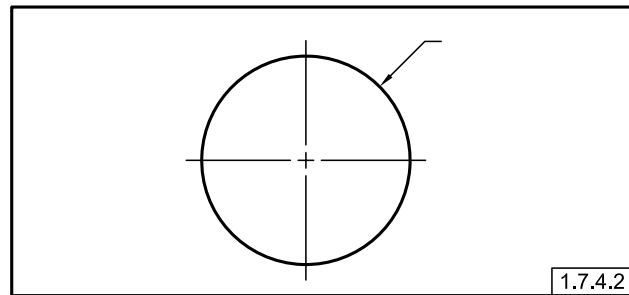


Fig. 1-17 Leader Directions



**1.7.4.1 Leader-Directed Dimensions.** Leader-directed dimensions are specified individually to avoid complicated leaders. See Fig. 1-15. Where too many leaders would impair the legibility of the drawing, letters or symbols should be used to identify features. See Fig. 1-16.

**1.7.4.2 Circle and Arc.** Where a leader is directed to a circle or an arc, its direction should be radial. See Fig. 1-17.

## 1.7.5 Reading Direction

Reading direction for the following specifications apply:

**1.7.5.1 Notes.** Notes should be placed to read from the bottom of the drawing with regard to the orientation of the drawing format.

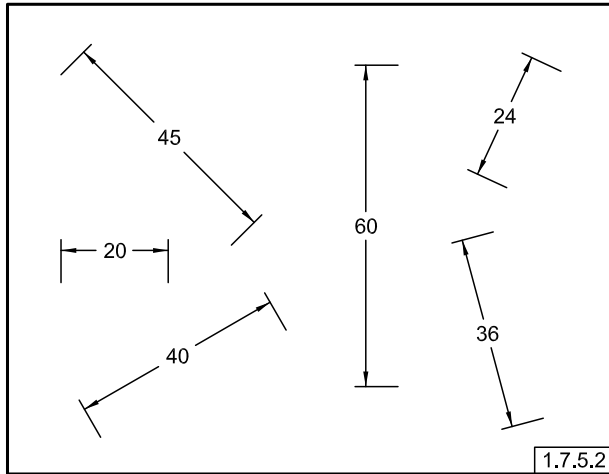
**1.7.5.2 Dimensions.** Dimensions shown with dimension lines and arrowheads should be placed to read from the bottom of the drawing. See Fig. 1-18.

**1.7.5.3 Baseline Dimensioning.** Baseline dimensions should be shown aligned to their extension lines and read from the bottom or right side of the drawing. See Fig. 1-50.

**1.7.5.4 Feature Control Frames.** Feature control frames should be placed to read from the bottom of the drawing.

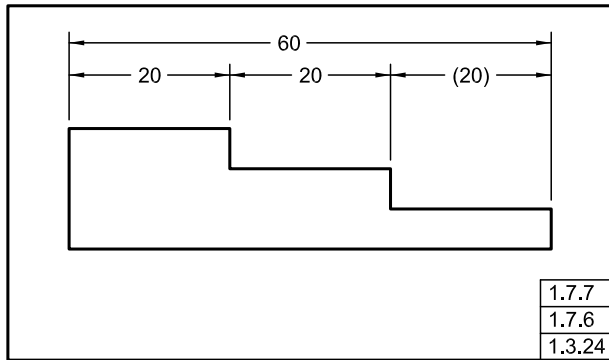


**Fig. 1-18 Reading Direction**



1.7.5.2

**Fig. 1-19 Intermediate Reference Dimension**



1.7.7  
1.7.6  
1.3.24

**1.7.5.5 Datum Feature Symbols.** Datum feature symbols should be placed to read from the bottom of the drawing.

**1.7.6 Reference Dimensions**

The method for identifying a reference dimension (or reference data) on drawings is to enclose the dimension (or data) within parentheses. See Figs. 1-19 and 1-20.

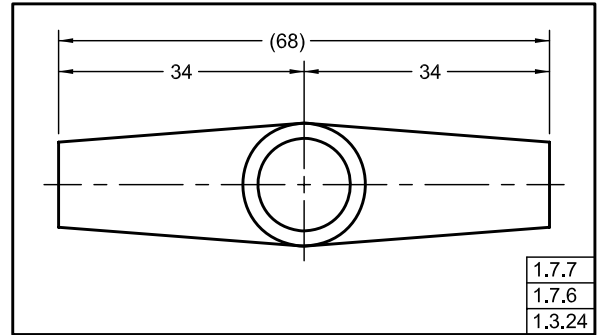
**1.7.7 Overall Dimensions**

Where an overall dimension is specified, one intermediate dimension is omitted or identified as a reference dimension. See Fig. 1-19. Where the intermediate dimensions are more important than the overall dimension, the overall dimension, if used, is identified as a reference dimension. See Fig. 1-20.

**1.7.8 Dimensioning Within the Outline of a View**

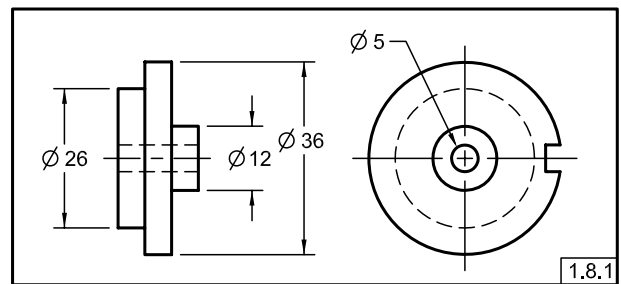
Dimensions are usually placed outside the outline of a view. Where directness of application makes it desirable, or where extension lines or leader lines would be

**Fig. 1-20 Overall Reference Dimension**



1.7.7  
1.7.6  
1.3.24

**Fig. 1-21 Diameters**



1.8.1

excessively long, dimensions may be placed within the outline of a view.

**1.7.9 Dimensions Not to Scale**

Agreement should exist between the pictorial presentation of a feature and its defining dimension. Where a change to a feature is made, the following, as applicable, must be observed.

(a) Where the sole authority for the product definition is a hard-copy original drawing prepared either manually or on an interactive computer graphics system, and it is not feasible to update the pictorial view of the feature, the defining dimension is to be underlined with a straight thick line. Where a basic dimension symbol is used, the line is placed beneath the symbol.

(b) Where the sole authority for the product definition is a model (digital), refer to ASME Y14.41.

**1.8 DIMENSIONING FEATURES**

Various characteristics and features require unique methods of dimensioning.

**1.8.1 Diameters**

The diameter symbol precedes all diametral values. See Fig. 1-21 and para. 3.3.7. Where the diameter of a spherical feature is specified, the diametral value is preceded by the spherical diameter symbol. See Fig. 3-11 and para. 3.3.7. Where the diameters of a number of concentric

Fig. 1-22 Radii

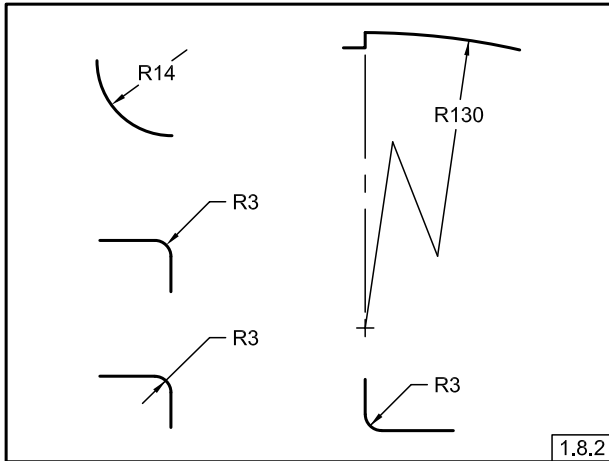


Fig. 1-24 Radii With Unlocated Centers

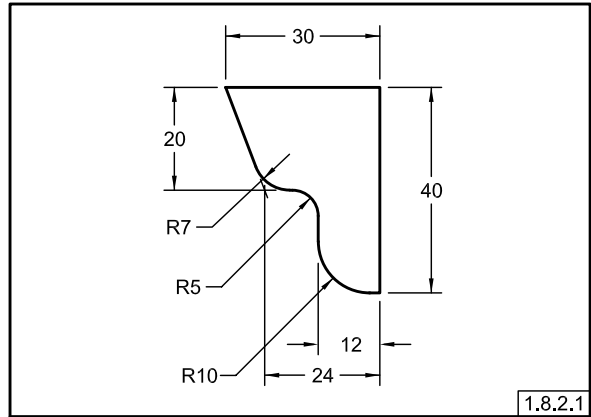


Fig. 1-23 Radius With Located Center

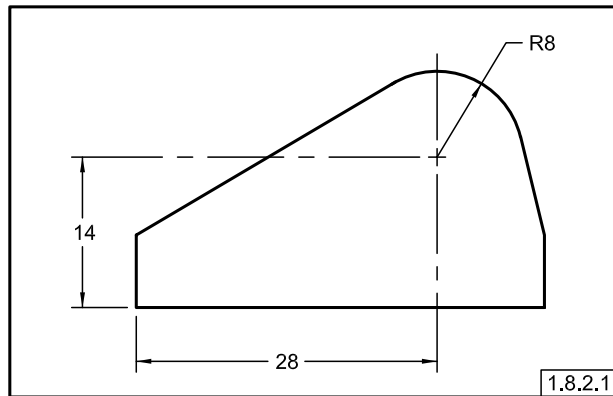
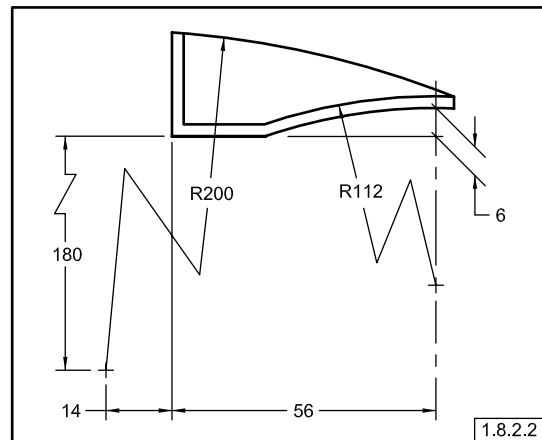


Fig. 1-25 Foreshortened Radii



cylindrical features are specified, such diameters should be dimensioned in a longitudinal view if practical.

**1.8.2 Radii**

Each radius value is preceded by the appropriate radius symbol. See Figs. 1-22 and 3-11 and para. 3.3.7. A radius dimension line uses one arrowhead, at the arc end. An arrowhead is never used at the radius center. Where location of the center is important and space permits, a dimension line is drawn from the radius center with the arrowhead touching the arc, and the dimension is placed between the arrowhead and the center. Where space is limited, the dimension line is extended through the radius center. Where it is inconvenient to place the arrowhead between the radius center and the arc, it may be placed outside the arc with a leader. Where the center of a radius is not dimensionally located, the center shall not be indicated. See Fig. 1-22.

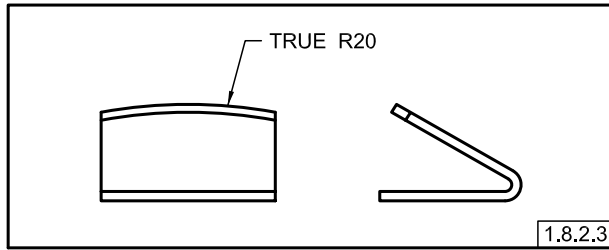
**1.8.2.1 Center of Radius.** Where a dimension is given to the center of a radius, a small cross is drawn at

the center. Extension lines and dimension lines are used to locate the center. See Fig. 1-23. Where location of the center is unimportant, the drawing must clearly show that the arc location is controlled by other dimensioned features such as tangent surfaces. See Fig. 1-24.

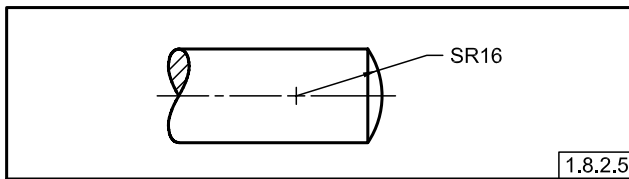
**1.8.2.2 Foreshortened Radii.** Where the center of a radius is outside the drawing or interferes with another view, the radius dimension line may be foreshortened. See Fig. 1-25. That portion of the dimension line extending from the arrowhead is radial relative to the arc. Where the radius dimension line is foreshortened and the center is located by coordinate dimensions, the dimension line locating the center is also foreshortened.

**1.8.2.3 True Radius.** On a 2D orthographic drawing, where a radius is dimensioned in a view that does not show the true shape of the radius, TRUE is added before the radius dimension. See Fig. 1-26. This practice is applicable to other foreshortened features as well as radii. See Fig. 4-28.

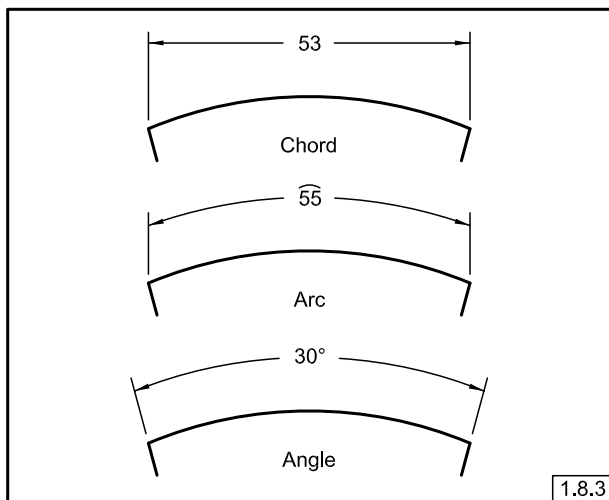
**Fig. 1-26 True Radius**



**Fig. 1-27 Spherical Radius**



**Fig. 1-28 Dimensioning Chords, Arcs, and Angles**



**1.8.2.4 Multiple Radii.** Where a part has a number of radii of the same dimension, a note may be used instead of dimensioning each radius separately.

**1.8.2.5 Spherical Radii.** Where a spherical surface is dimensioned by a radius, the radius dimension is preceded by the symbol SR. See Fig. 1-27.

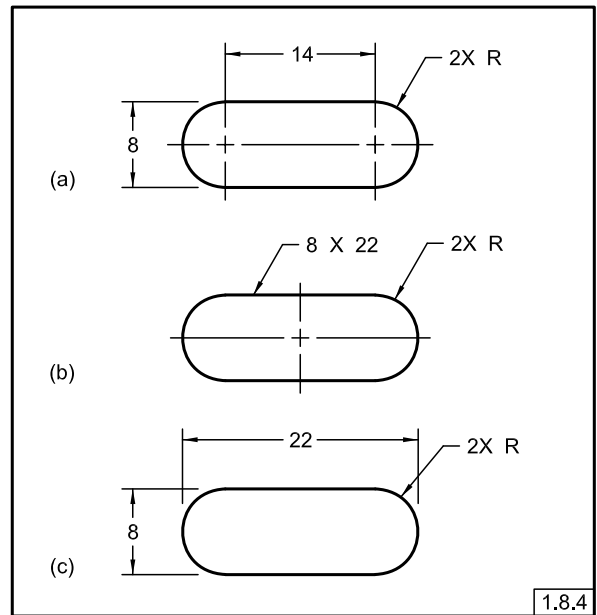
**1.8.3 Chords, Arcs, and Angles**

The dimensioning of chords, arcs, and angles shall be as shown in Fig. 1-28.

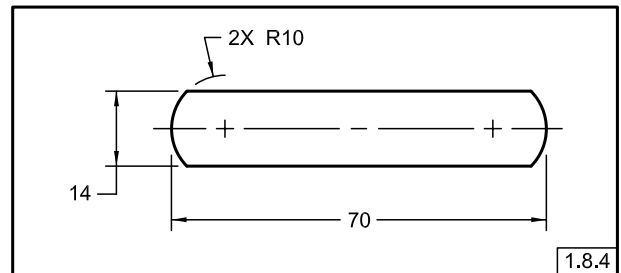
**1.8.4 Rounded Ends and Slotted Holes**

Features having rounded ends, including slotted holes, are dimensioned using one of the methods

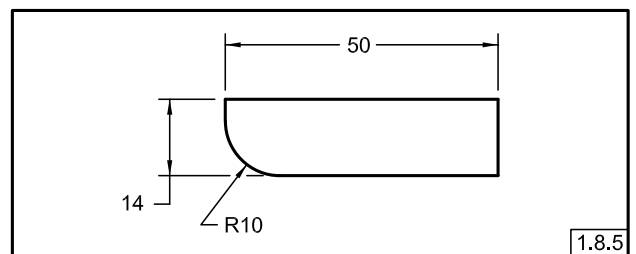
**Fig. 1-29 Slotted Holes**



**Fig. 1-30 Partially Rounded Ends**



**Fig. 1-31 Rounded Corners**

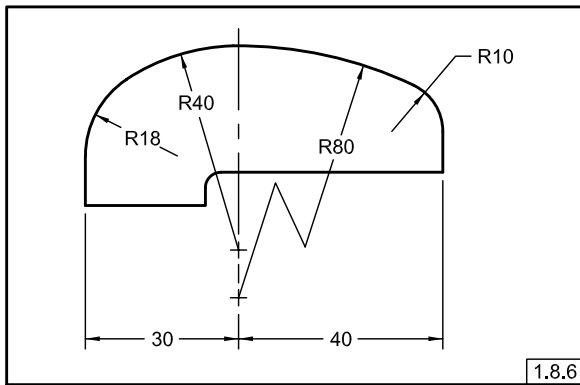


shown in Fig. 1-29. For fully rounded ends, the radii are indicated but not dimensioned. For features with partially rounded ends, the radii are dimensioned. See Fig. 1-30.

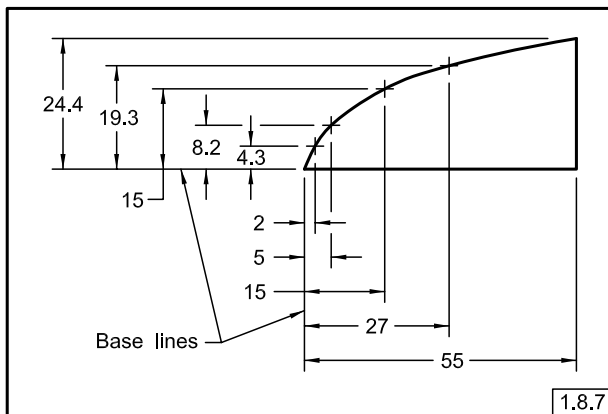
**1.8.5 Rounded Corners**

Where corners are rounded, dimensions define the edges, and the arcs are tangent. See Fig. 1-31.

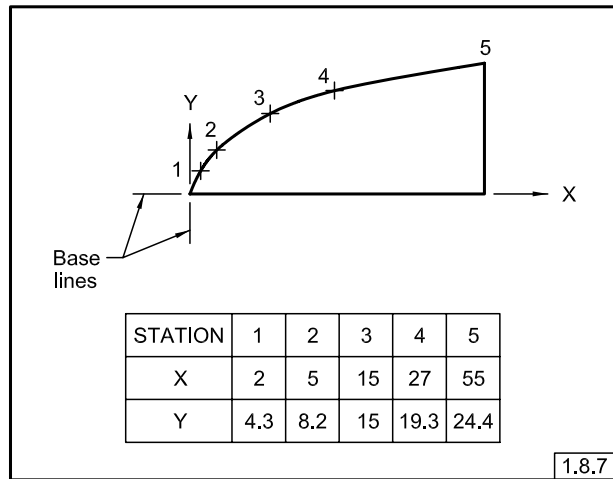
**Fig. 1-32 Circular Arc Outline**



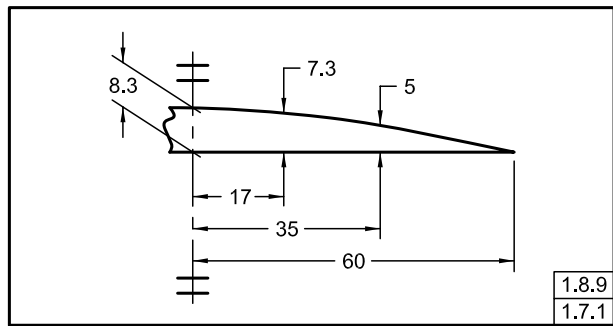
**Fig. 1-33 Coordinate or Offset Outline**



**Fig. 1-34 Tabulated Outline**



**Fig. 1-35 Symmetrical Outlines**



**1.8.6 Outlines Consisting of Arcs**

A curved outline composed of two or more arcs is dimensioned by giving the radii of all arcs and locating the necessary centers with coordinate dimensions. Other radii are located on the basis of their points of tangency. See Fig. 1-32.

**1.8.7 Irregular Outlines**

Irregular outlines may be dimensioned as shown in Figs. 1-33 and 1-34. Circular or noncircular outlines may be dimensioned by the rectangular coordinate or offset method. See Fig. 1-33. Coordinates are dimensioned from base lines. Where many coordinates are required to define an outline, the vertical and horizontal coordinate dimensions may be tabulated, as in Fig. 1-34.

**1.8.8 Grid System**

Curved pieces that represent patterns may be defined by a grid system with numbered grid lines.

**1.8.9 Symmetrical Outlines**

Symmetrical outlines may be dimensioned on one side of the center line of symmetry. Such is the case where,

due to the size of the part or space limitations, only part of the outline can be conveniently shown. See Fig. 1-35. One-half the outline of the symmetrical shape is shown and symmetry is indicated by applying symbols for part symmetry to the center line. See ASME Y14.2.

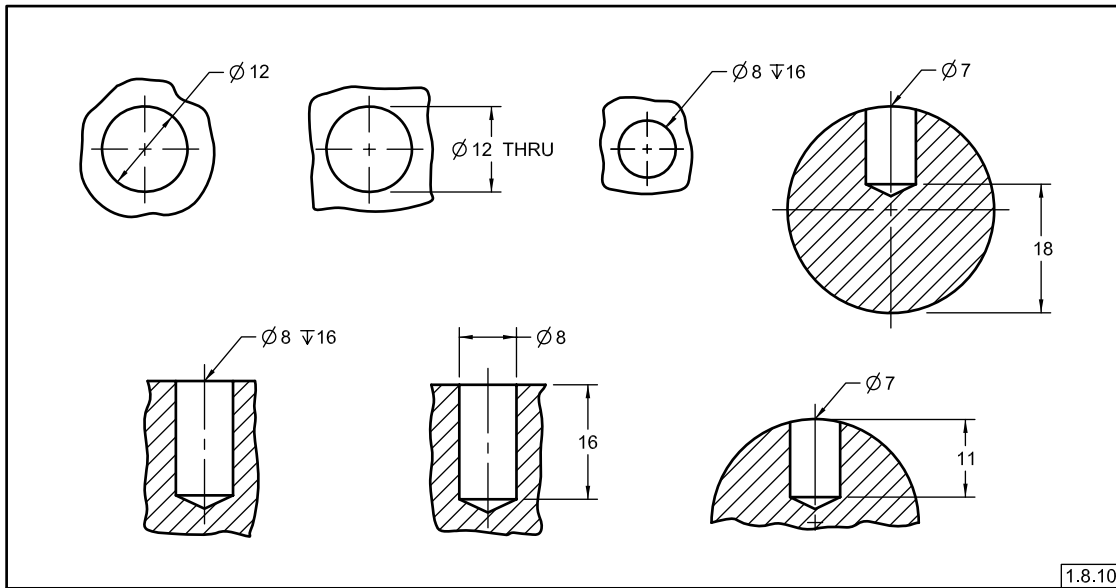
**1.8.10 Round Holes**

Round holes are dimensioned as shown in Fig. 1-36. Where it is not clear that a hole goes through, the notation THRU follows a dimension. Where multiple features are involved, additional clarification may be required. The depth dimension of a blind hole is the depth of the full diameter from the outer surface of the part. Where the depth dimension is not clear, as from a curved surface, the depth should be dimensioned pictorially. For methods of specifying blind holes, see Fig. 1-36.

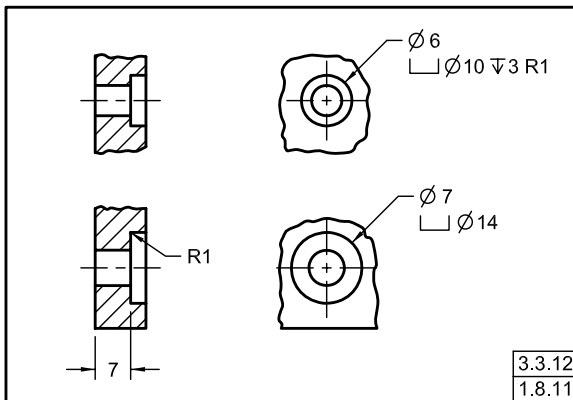
**1.8.11 Counterbored Holes**

Counterbored holes may be specified as shown in Fig. 1-37. Where the thickness of the remaining material has significance, this thickness (rather than the depth) is dimensioned. The relationship of the counterbore and the hole shall be specified. See Figs. 7-24 and 7-25. For holes having more than one counterbore,

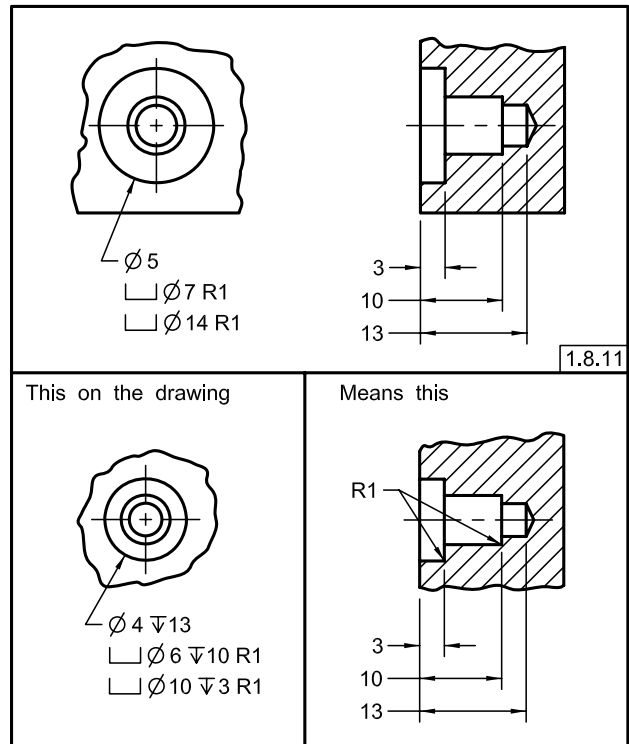
**Fig. 1-36 Round Holes**



**Fig. 1-37 Counterbored Holes**



**Fig. 1-38 Counterbored Holes**



see Fig. 1-38. Where applicable, a fillet radius may be specified.

**1.8.12 Countersunk and Counterdrilled Holes**

For countersunk holes, the diameter and included angle of the countersink are specified. For counterdrilled holes, the diameter and depth of the counterdrill are specified. Specifying the included angle of the counterdrill is optional. See Fig. 1-39. The depth dimension is the depth of the full diameter of the counterdrill from the outer surface of the part.

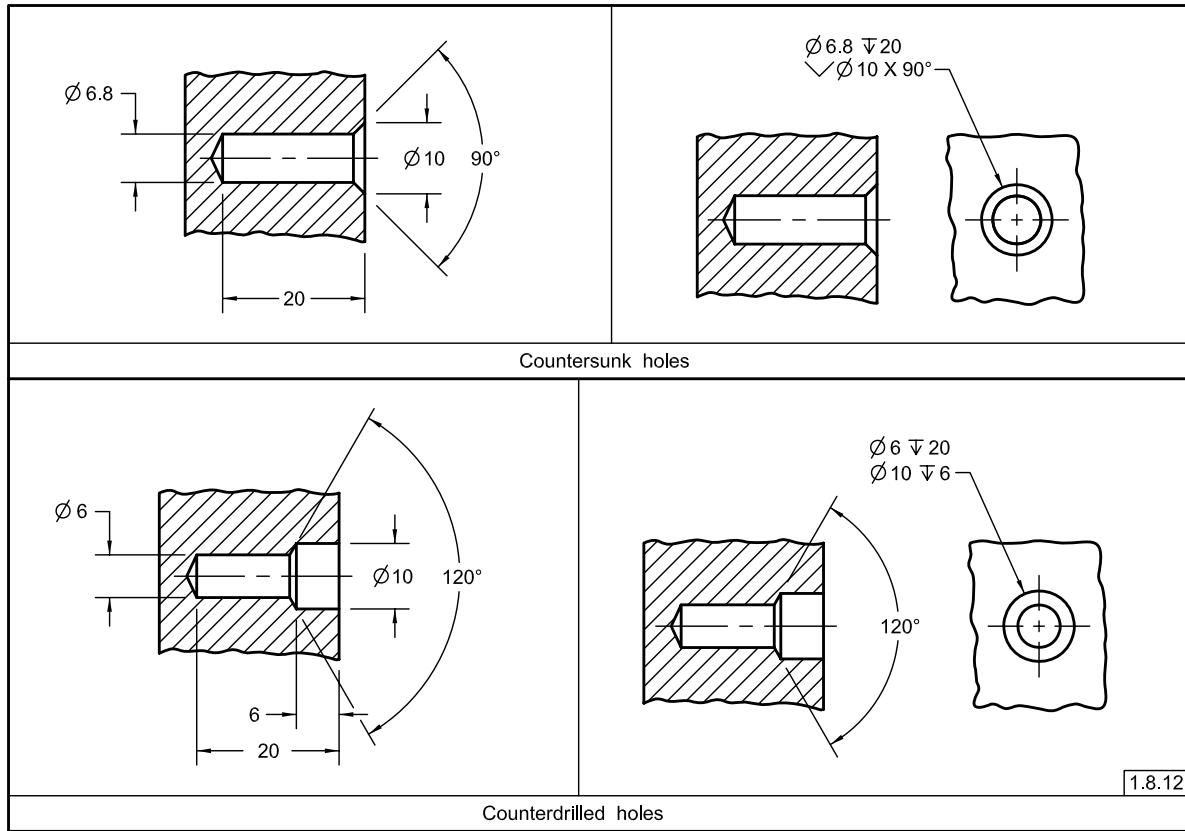
**1.8.13 Chamfered and Countersunk Holes on Curved Surfaces**

Where a hole is chamfered or countersunk on a curved surface, the diameter specified on the drawing applies at the minor diameter of the chamfer or countersink. See Fig. 1-40.

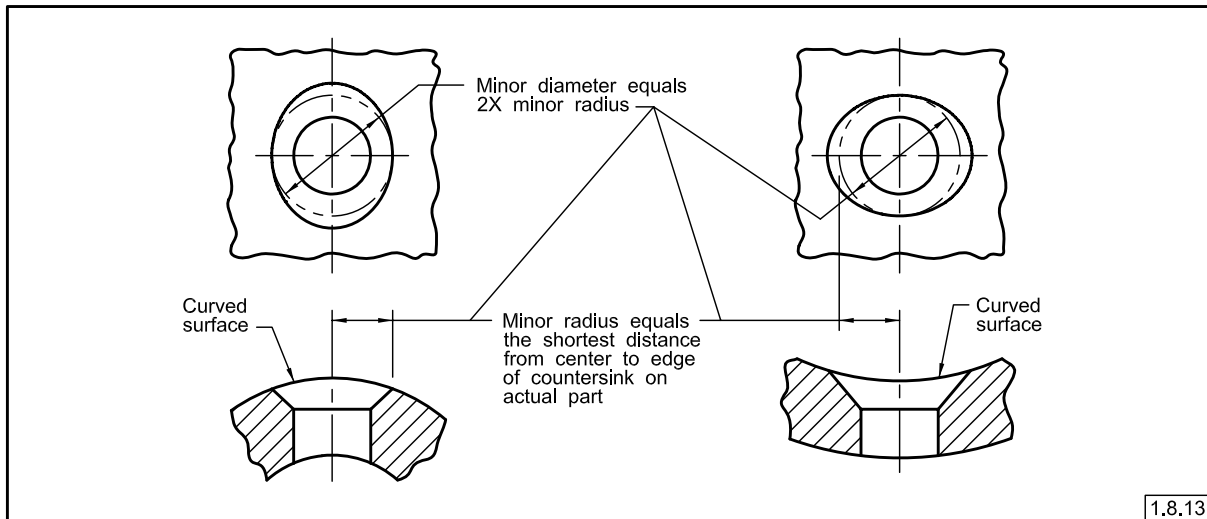
**1.8.14 Spotfaces**

Where the diameter of the spotfaced surface is specified, either the depth or the remaining thickness of material may be specified. If no depth or remaining thickness of material is specified, the spotface is the minimum depth necessary to clean up the surface to the specified diameter. Where applicable, a fillet

**Fig. 1-39 Countersunk and Counterdrilled Holes**



**Fig. 1-40 Countersink on a Curved Surface**

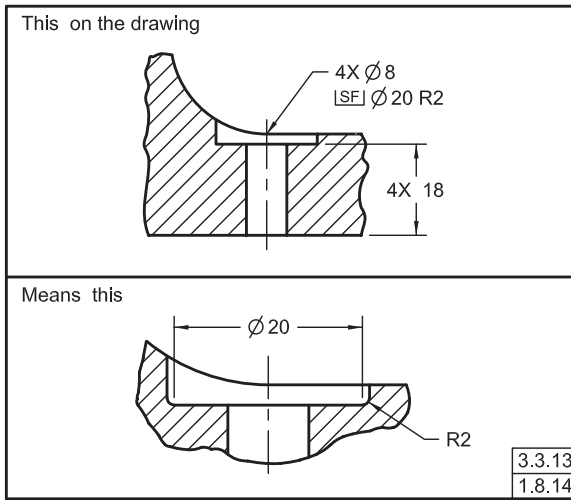


radius may be indicated for the spotface. In some cases, such as with a through hole, a notation may be necessary to indicate the surface to be spotfaced. See Fig. 1-41. A spotface may be specified by note only and need not be shown pictorially.

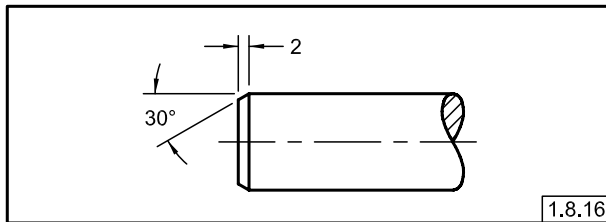
**1.8.15 Machining Centers**

Where machining centers are to remain on the finished part, they are indicated by a note or dimensioned on the drawing. See ASME B94.11M.

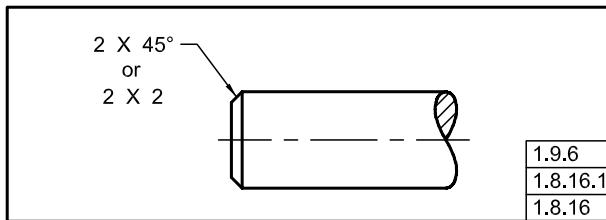
**Fig. 1-41 Spotfaced Holes**



**Fig. 1-42 Chamfers**



**Fig. 1-43 45° Chamfer**



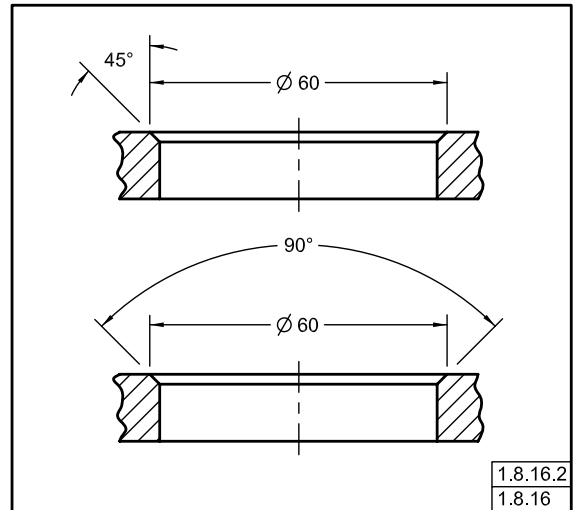
**1.8.16 Chamfers**

Chamfers are dimensioned by a linear dimension and an angle, or by two linear dimensions. See Figs. 1-42 through 1-45. Where an angle and a linear dimension are specified, the linear dimension is the distance from the indicated surface of the part to the start of the chamfer. See Fig. 1-42.

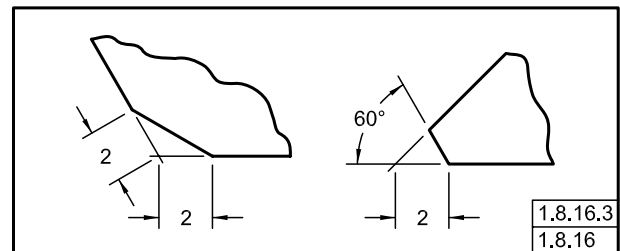
**1.8.16.1 Chamfers Specified by Note.** A note may be used to specify 45° chamfers on perpendicular surfaces. See Fig. 1-43. This method is used only with 45° chamfers, as the linear value applies in either direction.

**1.8.16.2 Round Holes.** Where the edge of a round hole is chamfered, the practice of para. 1.8.16.1 is followed, except where the chamfer diameter requires

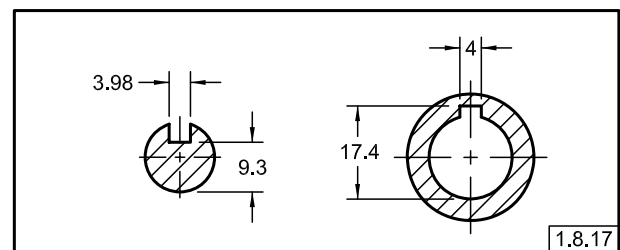
**Fig. 1-44 Internal Chamfers**



**Fig. 1-45 Chamfers Between Surfaces at Other Than 90°**



**Fig. 1-46 Keyseats**



dimensional control. See Fig. 1-44. This type of control may also be applied to the chamfer diameter on a shaft.

**1.8.16.3 Non-Perpendicular Intersecting Surfaces.** Two acceptable methods of dimensioning chamfers for surfaces intersecting at other than right angles are shown in Fig. 1-45.

**1.8.17 Keyseats**

Keyseats are dimensioned by width, depth, location, and if required, length. The depth may be dimensioned from the opposite side of the shaft or hole. See Fig. 1-46.

Fig. 1-47 Knurls

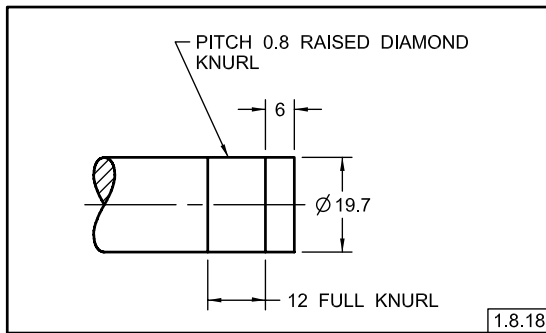
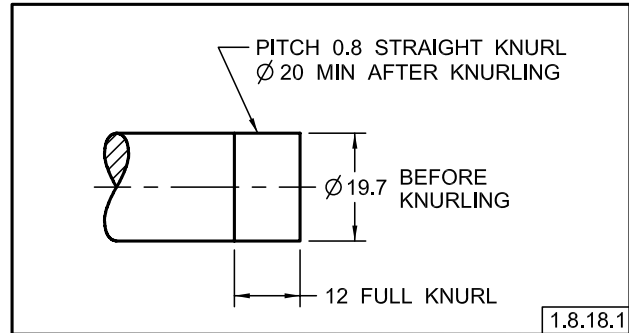


Fig. 1-48 Knurls for Press Fits



### 1.8.18 Knurling

Knurling is specified in terms of type, pitch, and diameter before and after knurling. Where control is not required, the diameter after knurling is omitted. Where only a portion of a feature requires knurling, the location and length of the knurl shall be specified. See Fig. 1-47.

**1.8.18.1 Knurling for Press Fit.** Where required to provide a press fit between parts, knurling is specified by a note that includes the type of knurl required, its pitch, the toleranced diameter of the feature before knurling, and the minimum acceptable diameter after knurling. See Fig. 1-48.

**1.8.18.2 Knurling Standard.** For information on inch knurling, see ANSI/ASME B94.6.

### 1.8.19 Rods and Tubing Details

Rods and tubing may be dimensioned in three coordinate directions and toleranced using geometric tolerances or by specifying the straight lengths, bend radii, angles of bend, and angles of twist for all portions of each feature. This may be done by means of auxiliary views, tabulation, or supplementary data.

### 1.8.20 Screw Threads

Methods of specifying and dimensioning screw threads are covered in ASME Y14.6.

### 1.8.21 Surface Texture

Methods of specifying surface texture requirements are covered in ASME Y14.36M. For additional information, see ASME B46.1.

### 1.8.22 Involute Splines

Methods of specifying involute spline requirements are covered in the ANSI B92 series of standards.

### 1.8.23 Castings, Forgings, and Molded Parts

Methods of specifying requirements peculiar to castings, forgings, and molded parts are covered in ASME Y14.8.

## 1.9 LOCATION OF FEATURES

Rectangular coordinate or polar coordinate dimensions locate features with respect to one another, and as a group or individually, from a datum or an origin. The features that establish this datum or origin must be identified. See para. 7.2.1.3. Round holes or other features of symmetrical contour are located by giving distances, or distances and directions, to the feature centers.

### 1.9.1 Rectangular Coordinate Dimensioning

Where rectangular coordinate dimensioning is used to locate features, linear dimensions specify distances in coordinate directions from two or three mutually perpendicular planes. See Fig. 1-49. Coordinate dimensioning must clearly indicate which features of the part establish these planes. For methods to accomplish this, see Figs. 4-2 and 4-8.

### 1.9.2 Rectangular Coordinate Dimensioning Without Dimension Lines

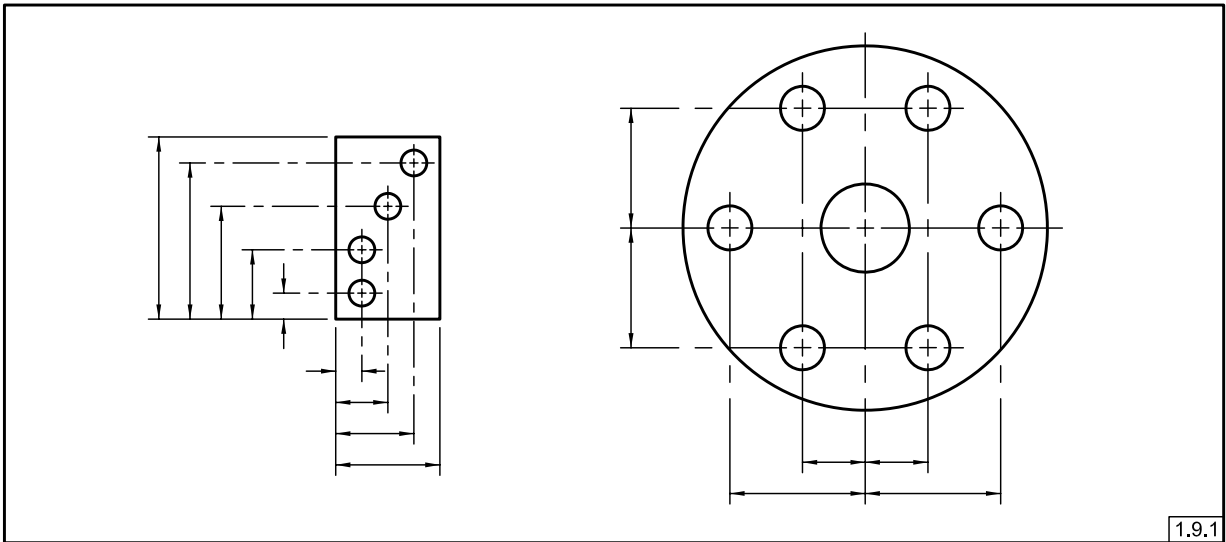
Dimensions may be shown on extension lines without the use of dimension lines or arrowheads. The base lines are indicated as zero coordinates. See Fig. 1-50.

### 1.9.3 Tabular Dimensioning

Tabular dimensioning is a type of rectangular coordinate dimensioning in which dimensions from mutually perpendicular planes are listed in a table on the drawing, rather than on the pictorial delineation. See Fig. 1-51. Tables are prepared in any suitable manner that adequately locates the features.

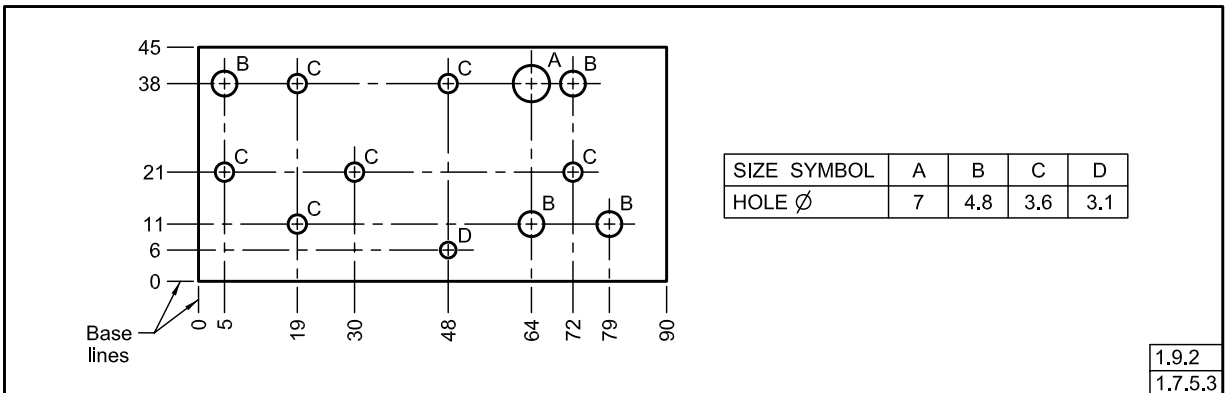


**Fig. 1-49 Rectangular Coordinate Dimensioning**



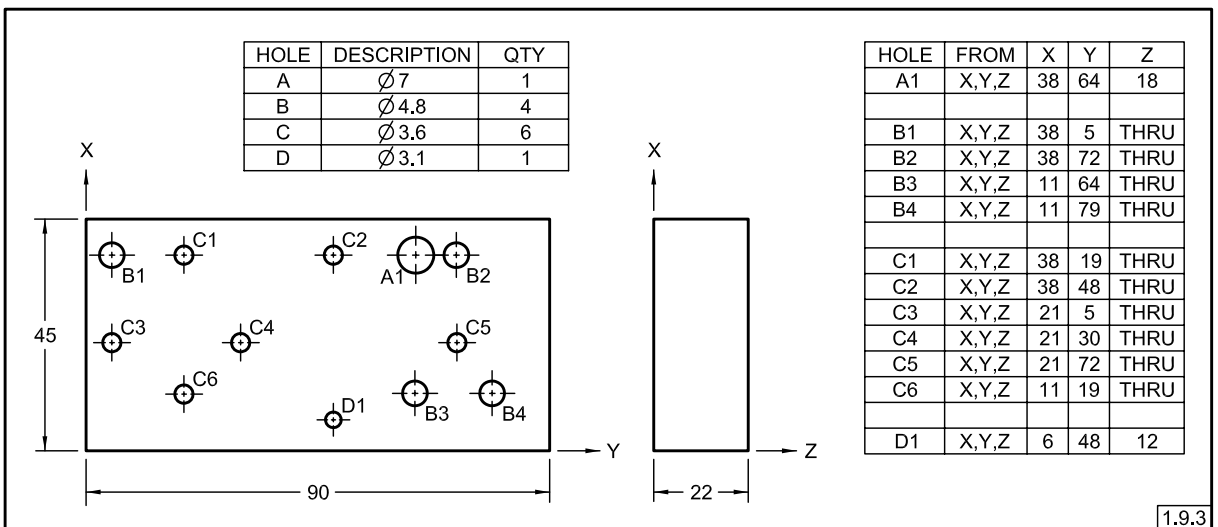
1.9.1

**Fig. 1-50 Rectangular Coordinate Dimensioning Without Dimension Lines**



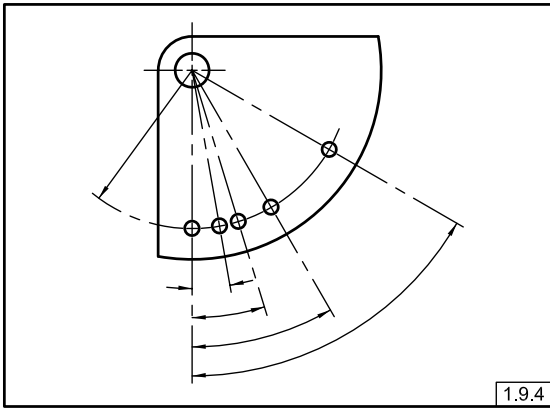
1.9.2  
1.7.5.3

**Fig. 1-51 Rectangular Coordinate Dimensioning in Tabular Form**



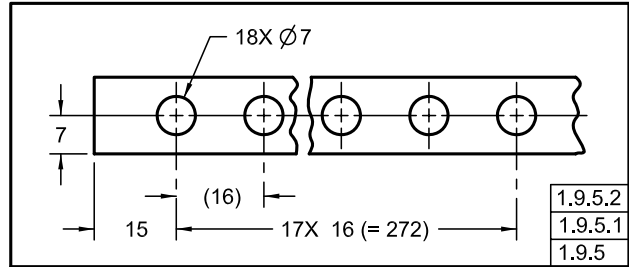
1.9.3

**Fig. 1-52 Polar Coordinate Dimensioning**



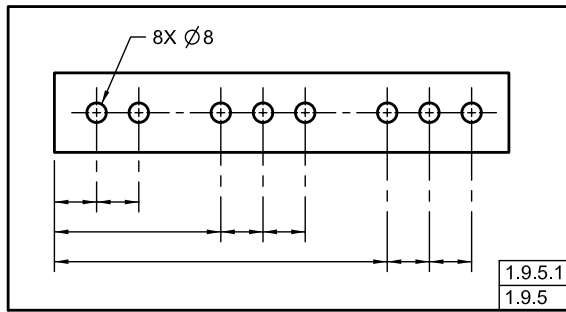
1.9.4

**Fig. 1-55 Repetitive Features and Dimensions**



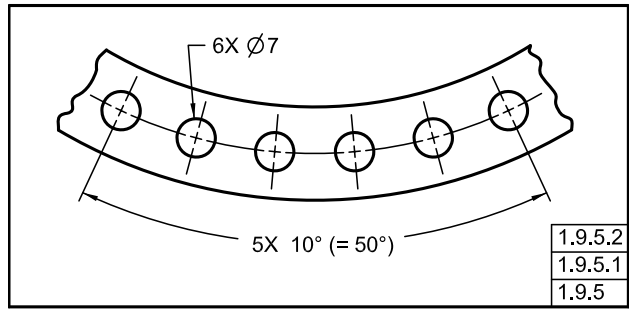
1.9.5.2
1.9.5.1
1.9.5

**Fig. 1-53 Repetitive Features**



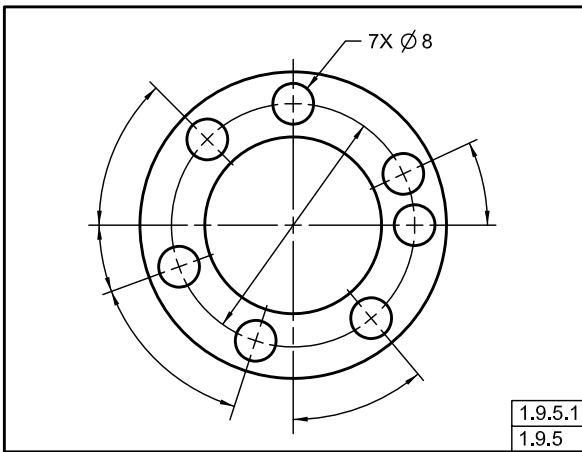
1.9.5.1
1.9.5

**Fig. 1-56 Repetitive Features and Dimensions**



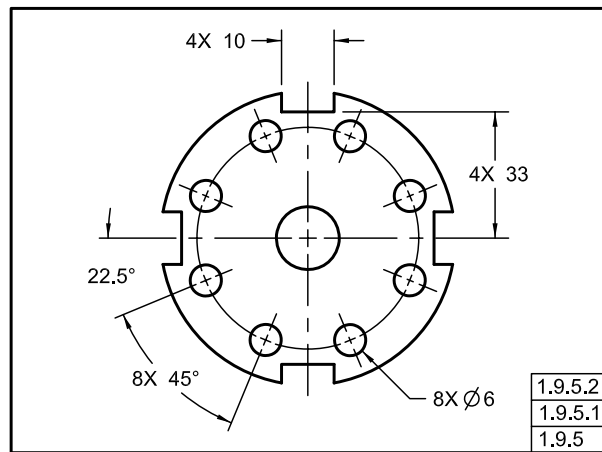
1.9.5.2
1.9.5.1
1.9.5

**Fig. 1-54 Repetitive Features**



1.9.5.1
1.9.5

**Fig. 1-57 Repetitive Features and Dimensions**



1.9.5.2
1.9.5.1
1.9.5

**1.9.4 Polar Coordinate Dimensioning**

Where polar coordinate dimensioning is used to locate features, a linear and an angular dimension specifies a distance from a fixed point at an angular direction from two or three mutually perpendicular planes. The fixed point is the intersection of these planes. See Fig. 1-52.

**1.9.5 Repetitive Features or Dimensions**

Repetitive features or dimensions may be specified by the use of an X in conjunction with a numeral to indicate the “number of places” required. See Figs. 1-53 through 1-57. Where used with a basic dimension, the X may be placed either inside or outside the basic dimension frame.

A space is used between the X and the dimension. See Figs. 4-39 and 7-16.

**1.9.5.1 Series and Patterns.** Features, such as holes and slots, which are repeated in a series or pattern, may be specified by giving the required number of features and an X followed by the size dimension of the feature. A space is used between the X and the dimension. See Figs. 1-53 through 1-57.

**1.9.5.2 Spacing.** Equal spacing of features in a series or pattern may be specified by giving the required number of spaces and an X, followed by the applicable dimension. A space is used between the X and the

dimension. See Figs. 1-55 through 1-57. Where it is difficult to distinguish between the dimension and the number of spaces, as in Fig. 1-55, one space may be dimensioned and identified as reference.

#### **1.9.6 Use of X to Indicate “By”**

An X may be used to indicate “by” between coordinate dimensions as shown in Fig. 1-43. In such cases, the X shall be preceded and followed by one character space.

NOTE: Where the practices described in paras. 1.9.5 and 1.9.6 are used on the same drawing; care must be taken to be sure each usage is clear.

## Section 2

# General Tolerancing and Related Principles

### 2.1 GENERAL

This Section establishes practices for expressing tolerances on linear and angular dimensions, applicability of material condition modifiers on geometric tolerance values, and interpretations governing limits and tolerances.

NOTE: If a model (digital) is used to define the tolerances of the part, see ASME Y14.41 for additional requirements.

#### 2.1.1 Application

Tolerances may be expressed as follows:

- (a) as direct limits or as tolerance values applied directly to a dimension. See para. 2.2.
- (b) as a geometric tolerance, as described in Sections 5 through 9.
- (c) in a note or table referring to specific dimensions.
- (d) as specified in other documents referenced on the drawing for specific features or processes.
- (e) in a general tolerance block referring to all dimensions on a drawing for which tolerances are not otherwise specified.

**2.1.1.1 Positional Tolerancing Method.** Preferably, tolerances on dimensions that locate features of size are specified by the positional tolerancing method described in Section 7. In certain cases, such as locating irregular-shaped features, the profile tolerancing method described in Section 8 may be used.

**2.1.1.2 Basic Dimensions.** Basic dimensions may be indicated on the drawing in the following ways:

- (a) applying the basic dimension symbol to each of the basic dimensions. See Fig. 7-1, illustrations (a) and (b).
- (b) specifying on the drawing (or in a document referenced on the drawing) a general note such as: UNTOLERANCED DIMENSIONS ARE BASIC. See Fig. 7-1, illustration (c).

NOTE: Where using this method a plus/minus general tolerance is not allowed.

- (c) For specifying and querying basic dimensions on models or digital drawings with models, see ASME Y14.41.

**2.1.1.3 Implied 90° Angle.** By convention, where center lines and surfaces of features are depicted on 2D orthographic engineering drawings intersecting at right angles, a 90° angle is not specified. Implied 90° angles are understood

to apply. The tolerance on these implied 90° angles is the same as for all other angular features shown on the field of the drawing governed by general angular tolerance notes or general tolerance block values. See para 1.4(i).

**2.1.1.4 Implied 90° or 0° Basic Angle.** Where center lines and surfaces are depicted on 2D orthographic engineering drawings intersecting at right angles or parallel to each other and basic dimensions or geometric tolerances have been specified, implied 90° or 0° basic angles are understood to apply. The tolerance on the feature associated with these implied 90° or 0° basic angles is provided by feature control frames that govern the location, orientation, profile, or runout of features. See paras. 1.4(j) and (k).

### 2.2 DIRECT TOLERANCING METHODS

Limits and directly applied tolerance values are specified as follows.

- (a) *Limit Dimensioning.* The high limit (maximum value) is placed above the low limit (minimum value). When expressed in a single line, the low limit precedes the high limit and a dash separates the two values. See Fig. 2-1.
- (b) *Plus and Minus Tolerancing.* The dimension is given first and is followed by a plus and minus expression of tolerance. See Fig. 2-2.
- (c) *Geometric Tolerances Directly Applied to Features.* See Sections 5 through 9.

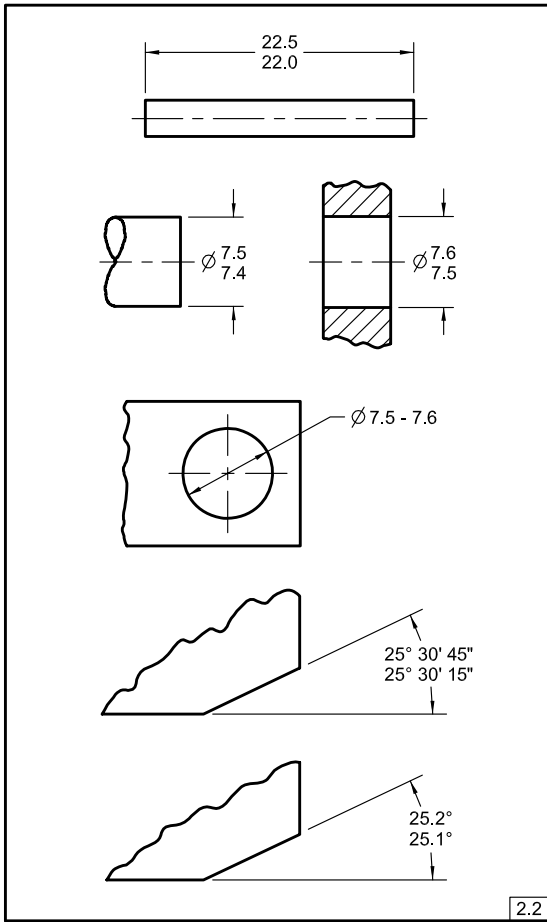
#### 2.2.1 Metric Limits and Fits

For metric application of limits and fits, the tolerance may be indicated by a basic size and tolerance symbol as in Fig. 2-3. See ANSI B4.2 for complete information on this system.

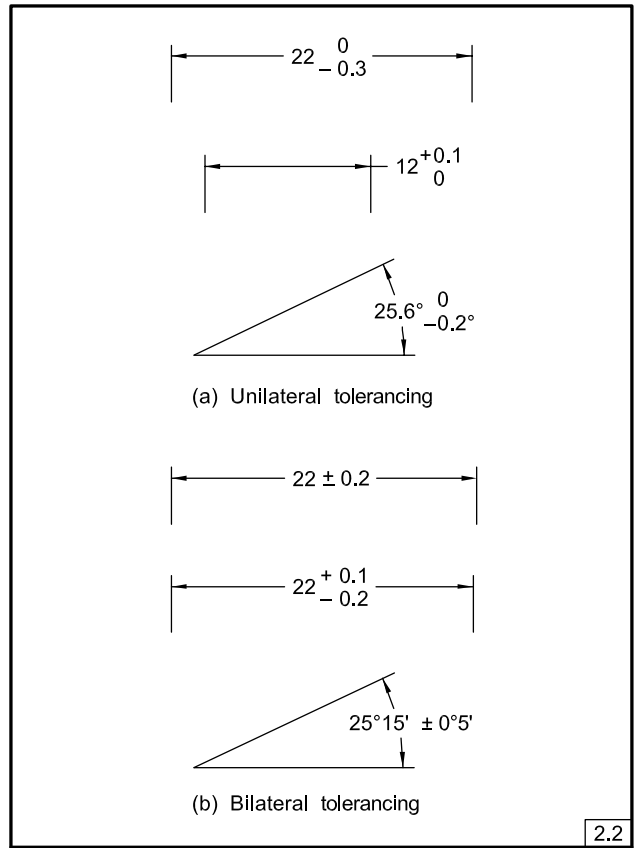
**2.2.1.1 Limits and Tolerance Symbols.** The method shown in Fig. 2-3, illustration (a) is recommended when the system is introduced by an organization. In this case, limit dimensions are specified, and the basic size and tolerance symbol are identified as reference.

**2.2.1.2 Tolerance Symbol and Limits.** As experience is gained, the method shown in Fig. 2-3, illustration (b) may be used. When the system is established and standard tools, gages, and stock materials are available with size and symbol identification, the method shown in Fig. 2-3, illustration (c) may be used.

**Fig. 2-1 Limit Dimensioning**



**Fig. 2-2 Plus and Minus Tolerancing**



**2.3 TOLERANCE EXPRESSION**

The conventions shown in the following paragraphs shall be observed pertaining to the number of decimal places carried in the tolerance.

**2.3.1 Millimeter Tolerances**

Where millimeter dimensions are used on the drawings, the following apply.

(a) Where unilateral tolerancing is used and either the plus or minus value is nil, a single zero is shown without a plus or minus sign. In this example the 32 value is the nominal size.

**EXAMPLE:**

32	0	or	32	+0.02
	-0.02			0

**Fig. 2-3 Indicating Symbols for Metric Limits and Fits**

(a)	29.980 29.959 (30f7)	
(b)	30f7 (29.980 29.959)	3.3.8 2.2.1.2
(c)	30f7	2.2.1.1 2.2.1

(b) Where bilateral tolerancing is used, both the plus and minus values have the same number of decimal places, using zeros where necessary. In this example the 32 value is the nominal size.

**EXAMPLE:**

32	+0.25 -0.10	not	32	+0.25 -0.1
----	----------------	-----	----	---------------

(c) Where limit dimensioning is used and either the maximum or minimum value has digits following

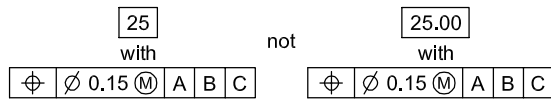
a decimal point, the other value has zeros added for uniformity.

**EXAMPLE:**

25.45		25.45
25.00	not	25

(d) Where basic dimensions are used, associated tolerances contain the number of decimal places necessary for control. The basic dimension value observes the practices of para. 1.6.1.

**EXAMPLE:**



**2.3.2 Inch Tolerances**

Where inch dimensions are used on the drawing, the following apply:

(a) Where unilateral tolerancing is used and either the plus or minus value is nil, its dimension shall be expressed with the same number of decimal places, and the appropriate plus or minus sign.

**EXAMPLE:**

.500	+ .005		not	.500	+ .005
	- .000				0

(b) Where bilateral tolerancing is used, both the plus and minus values and the dimension have the same number of decimal places.

**EXAMPLE:**

.500 ± .005	not	.50 ± .005
-------------	-----	------------

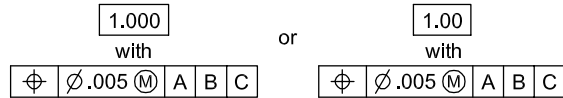
(c) Where limit dimensioning is used and either the maximum or minimum value has digits following a decimal point, the other value has zeros added for uniformity.

**EXAMPLE:**

.750		.75
.748	not	.748

(d) Where basic dimensions are used, associated tolerances contain the number of decimal places necessary for control. There is no requirement for the basic dimension value to be expressed with the same number of decimal places as the tolerance.

**EXAMPLE:**



**2.3.3 Angle Tolerances**

Where angle dimensions are used, both the plus and minus values and the angle have the same number of decimal places.

**EXAMPLE:**

25.0° ± 0.2°	not	25° ± .2°
25° ± 0°30'	not	25° ± 30'

**2.4 INTERPRETATION OF LIMITS**

All limits are absolute. Dimensional limits, regardless of the number of decimal places, are used as if they were continued with zeros.

**EXAMPLES:**

12.2	means	12.20...0
12.0	means	12.00...0
12.01	means	12.010...0

**2.4.1 Plated or Coated Parts**

Where a part is to be plated or coated, the drawing or referenced document shall specify whether the dimensions apply before or after plating. Typical examples of notes are the following:

- (a) "DIMENSIONAL LIMITS APPLY AFTER PLATING."
  - (b) "DIMENSIONAL LIMITS APPLY BEFORE PLATING."
- (For processes other than plating, substitute the appropriate term.)

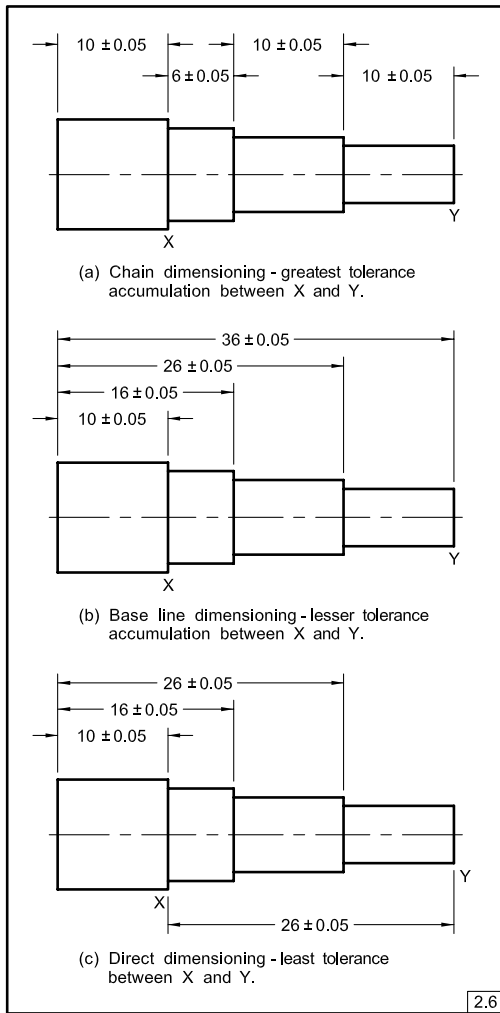
**2.5 SINGLE LIMITS**

MIN or MAX is placed after a dimension where other elements of the design definitely determine the other unspecified limit. Features, such as depths of holes, lengths of threads, corner radii, chamfers, etc., may be limited in this way. Single limits are used where the intent will be clear, and the unspecified limit can be zero or approach infinity and will not result in a condition detrimental to the design.

**2.6 TOLERANCE ACCUMULATION**

Figure 2-4 compares the tolerance values resulting from the following three methods of dimensioning.

**Fig. 2-4 Tolerance Accumulation**



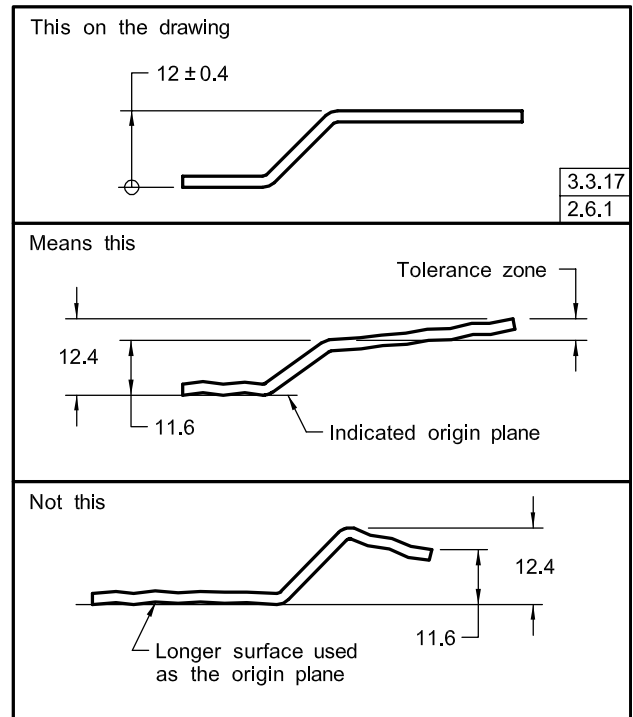
(a) *Chain Dimensioning.* The maximum variation between two features is equal to the sum of the tolerances on the intermediate distances; this results in the greatest tolerance accumulation. In Fig. 2-4, illustration (a), the tolerance accumulation between surfaces X and Y is  $\pm 0.15$ .

(b) *Base Line Dimensioning.* The maximum variation between two features is equal to the sum of the tolerances on the two dimensions from their origin to the features; this results in a reduction of the tolerance accumulation. In Fig. 2-4, illustration (b), the tolerance accumulation between surfaces X and Y is  $\pm 0.1$ .

(c) *Direct Dimensioning.* The maximum variation between two features is controlled by the tolerance on the dimension between the features; this results in the least tolerance. In Fig. 2-4, illustration (c), the tolerance between surfaces X and Y is  $\pm 0.05$ .

NOTE: When basic dimensions are used, there is no accumulation of tolerances. A geometric tolerance is required to create the tolerance zone. In this case, the style of dimensioning (chain,

**Fig. 2-5 Relating Dimensional Limits to an Origin**



baseline, direct) is up to the discretion of the user. Locating features using directly toleranced dimensions is not recommended.

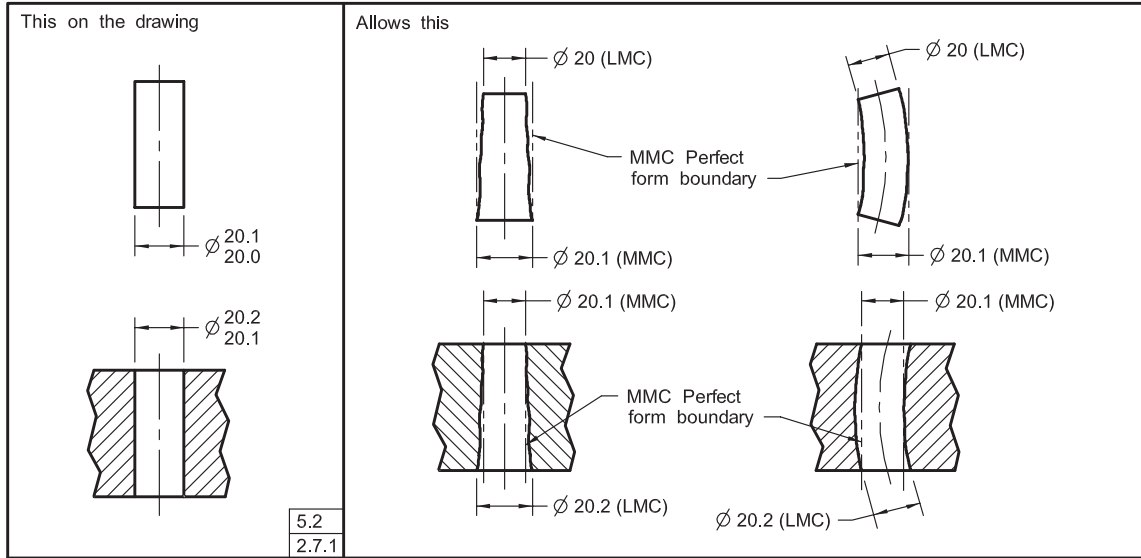
**2.6.1 Dimensional Limits Related to an Origin**

In certain cases, it is necessary to indicate that a dimension between two features shall originate from one of these features and not the other. The high points of the surface indicated as the origin define a plane for measurement. The dimensions related to the origin are taken from the plane or axis and define a zone within which the other features must lie. This concept does not establish a datum reference frame as described in Section 4. Such a case is illustrated in Fig. 2-5, where a part having two parallel surfaces of unequal length is to be mounted on the shorter surface. In this example, the dimension origin symbol described in para. 3.3.17 signifies that the dimension originates from the plane established by the shorter surface and dimensional limits apply to the other surface. Without such indication, the longer surface could have been selected as the origin, thus permitting a greater angular variation between surfaces.

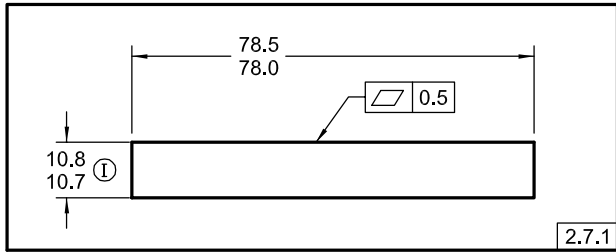
**2.7 LIMITS OF SIZE**

Unless otherwise specified, the limits of size of a feature prescribe the extent within which variations of geometric form, as well as size, are allowed. This control applies solely to individual regular features of size as

**Fig. 2-6 Extreme Variations of Form Allowed by a Size Tolerance**



**Fig. 2-7 Independency and Flatness Application**



defined in para. 1.3.32.1. The actual local size of an individual feature at each cross section shall be within the specified tolerance of size.

**2.7.1 Variations of Form (Rule #1: Envelope Principle)**

The form of an individual regular feature of size is controlled by its limits of size to the extent prescribed in the following paragraphs and illustrated in Fig. 2-6.

(a) The surface or surfaces of a regular feature of size shall not extend beyond a boundary (envelope) of perfect form at MMC. This boundary is the true geometric form represented by the drawing. No variation in form is permitted if the regular feature of size is produced at its MMC limit of size unless a straightness or flatness tolerance is associated with the size dimension or the Independency symbol is applied per para. 2.7.3. See Fig. 2-7.

(b) Where the actual local size of a regular feature of size has departed from MMC toward LMC, a local variation in form is allowed equal to the amount of such departure.

(c) Where is no default requirement for a boundary of perfect form at LMC. Thus, a regular feature of size produced at its LMC limit of size is permitted to vary

from true form to the maximum variation allowed by the boundary of perfect form at MMC.

(d) In cases where a geometric tolerance is specified to apply at LMC, perfect form at LMC is required. See para. 7.3.5.

**2.7.2 Form Control Does Not Apply (Exceptions to Rule #1)**

The control of geometric form prescribed by limits of size does not apply to the following:

(a) stock, such as bars, sheets, tubing, structural shapes, and other items produced to established industry or government standards that prescribe limits for straightness, flatness, and other geometric characteristics. Unless geometric tolerances are specified on the drawing of a part made from these items, standards for these items govern the surfaces that remain in the as-furnished condition on the finished part.

(b) parts subject to free-state variation in the unrestrained condition. See para. 5.5.

**2.7.3 Perfect Form at MMC Not Required**

Where perfect form at MMC is not required, the Independency symbol may be placed next to the appropriate dimension or notation. See Fig. 3-11 and para. 3.3.24.

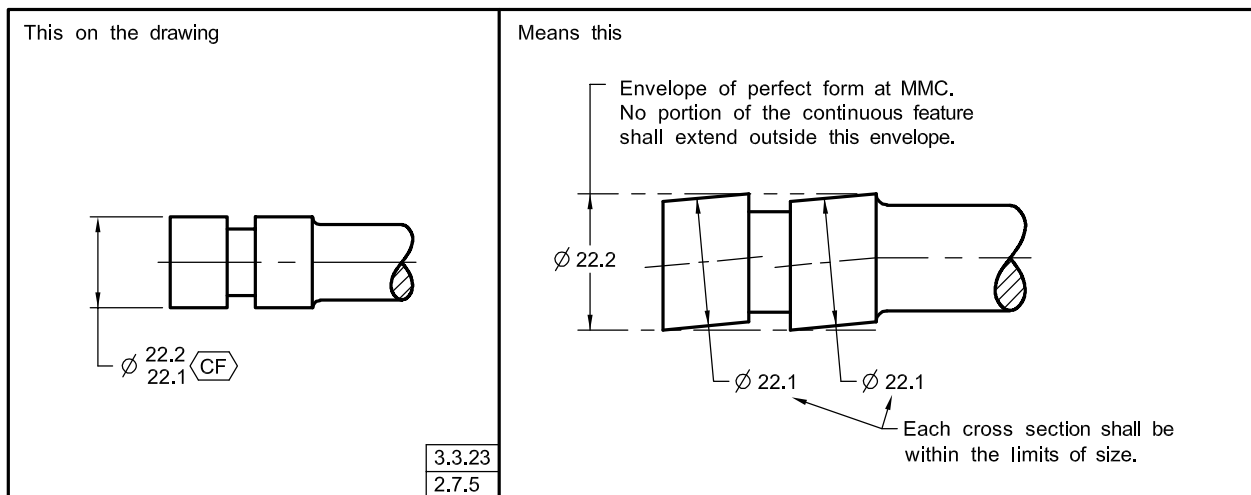
**CAUTION:** Without a supplementary form control, the feature form is entirely uncontrolled. See Fig. 2-7.

**2.7.4 Relationship Between Individual Features**

The limits of size do not control the orientation or location relationship between individual features. Features shown perpendicular, coaxial, or symmetrical



Fig. 2-8 Continuous Feature, External Cylindrical



to each other must be toleranced for location or orientation to avoid incomplete drawing requirements. These tolerances may be specified by one of the methods given in Sections 6 through 9. If it is necessary to establish a boundary of perfect form at MMC to control the relationship between features, one of the following methods may be used:

(a) Specify a zero tolerance of orientation at MMC, including a datum reference (at MMB if applicable), to control angularity, perpendicularity, or parallelism of the feature. See para. 6.4.4.

(b) Specify a zero positional tolerance at MMC, including any specified datum reference (at MMB if applicable) to control coaxial or symmetrical features. See paras. 7.6.2.2 and 7.7.1.1.

(c) Indicate this control for the features involved by a note such as “PERFECT ORIENTATION (or COAXIALITY or LOCATION OF SYMMETRICAL FEATURES) AT MMC REQUIRED FOR RELATED FEATURES.”

### 2.7.5 Limits of Size and Continuous Features of Size

The note “CONTINUOUS FEATURE” or continuous feature symbol is used to identify a group of two or more features of size where there is a requirement that they be treated geometrically as a single feature of size. When using the continuous feature symbol, extension lines between the features may be shown or omitted; however, extension lines by themselves do not indicate a continuous feature. See Figs. 2-8 through 2-10.

## 2.8 APPLICABILITY OF MODIFIERS ON GEOMETRIC TOLERANCE VALUES AND DATUM FEATURE REFERENCES

RFS, MMC, and LMC may be applied to geometric tolerance values on features of size. See Figs. 7-34 and 8-24.

RMB, MMB, and LMB may be applied to datum feature references. Rule #2 RFS applies, with respect to the individual tolerance, and RMB applies, with respect to the individual datum feature reference, where no modifying symbol is specified. MMC, LMC, MMB, or LMB shall be specified on the drawing where it is required.

### NOTES:

- (1) The following paragraphs describe the principles based on an axis interpretation for RFS, MMC, and LMC. In certain cases of surface deviation of the feature, the tolerance in terms of the feature axis or feature center plane may not be exactly equivalent to the tolerance in terms of the surface limited by a boundary. In such cases, the surface interpretation shall take precedence. See para. 7.3.3.1(a) and Fig. 7-6.
- (2) Circular runout, total runout, concentricity, profile of a line, profile of a surface, circularity, cylindricity, and symmetry tolerances are applicable only on an RFS basis and cannot be modified to MMC or LMC.

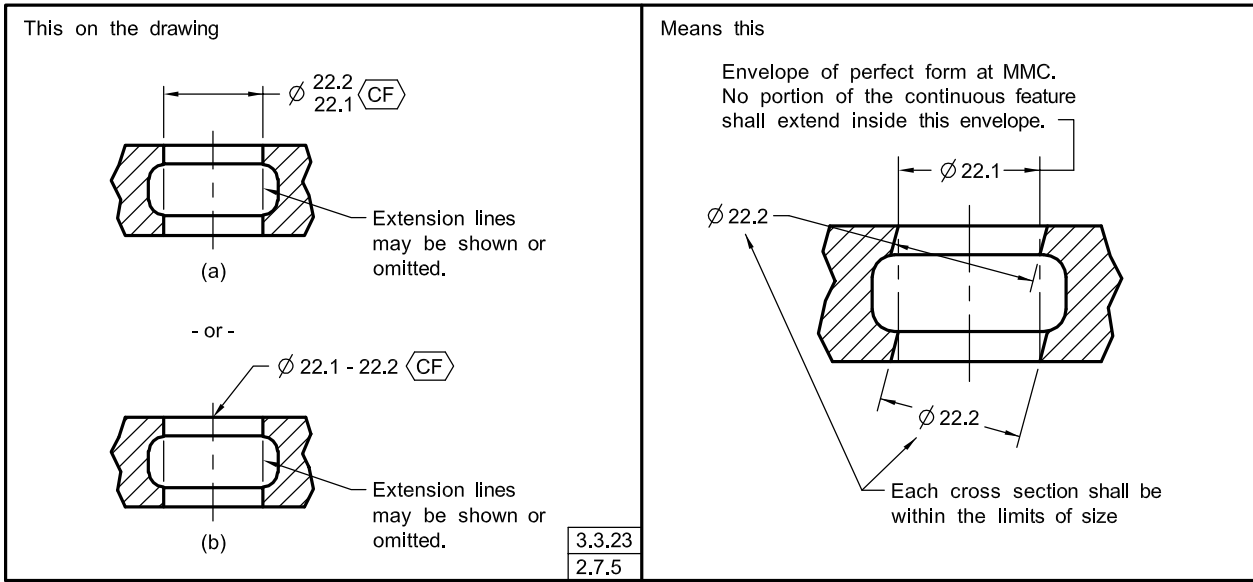
### 2.8.1 Effect of RFS

Where a geometric tolerance is applied on an RFS basis, the specified tolerance is independent of the size of the considered feature of size. The tolerance is limited to the specified value regardless of the size of the unrelated actual mating envelope.

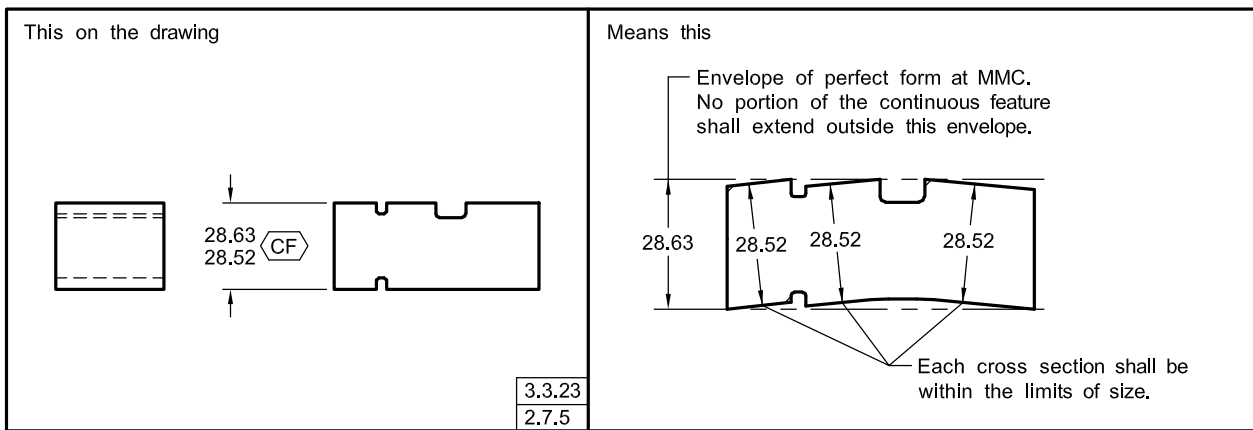
### 2.8.2 Effect of MMC

Where a geometric tolerance is applied on an MMC basis, the allowed tolerance is dependent on the size of the unrelated actual mating envelope of the considered feature when considering effects based on the axis interpretation. The tolerance is limited to the specified value if the feature is produced at its MMC limit of size. Where the size of the unrelated actual mating envelope of the feature has departed from MMC, an increase in the tolerance equal to the amount of such departure is

**Fig. 2-9 Continuous Feature, Internal Cylindrical**



**Fig. 2-10 Continuous Feature, External Width**



allowed. The total permissible variation in the specified geometric characteristic is maximum when the feature is at LMC, unless a maximum is specified.

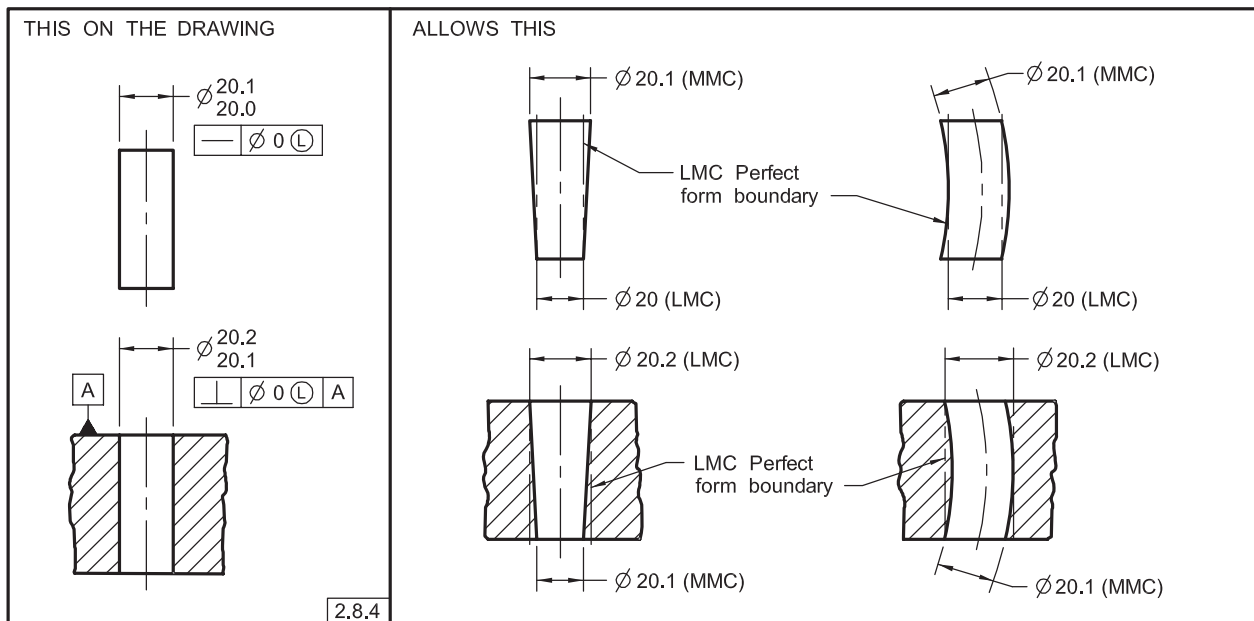
**2.8.3 Effect of Zero Tolerance at MMC**

Where a tolerance of position or orientation is applied on a zero tolerance at MMC basis, the tolerance is totally dependent on the size of the unrelated actual mating envelope of the considered feature. No tolerance of position or orientation is allowed if the feature is produced at its MMC limit of size; and in this case, it must be located at true position or be perfect in orientation, as applicable. Where the size of the unrelated actual mating envelope of the considered feature has departed from MMC, a tolerance equal to the amount of such departure is allowed. The total permissible variation in position or orientation

is maximum when the feature is at LMC, unless a maximum is specified. See Figs. 6-14 and 6-15.

**2.8.4 Effect of LMC**

Where a geometric tolerance is applied on an LMC basis, perfect form at LMC is required. Perfect form at MMC is not required. This is the reciprocal of the MMC concept. See Fig. 2-11. Where a geometric tolerance is applied on an LMC basis, the allowed tolerance is dependent on the unrelated actual minimum material envelope of the considered feature. The tolerance is limited to the specified value if the feature is produced at its LMC limit of size. Where the unrelated actual minimum material envelope of the feature has departed from LMC, an increase in the tolerance equal to the amount of such departure is allowed. The total permissible variation

**Fig. 2-11 Extreme Variations of Form Allowed by a Geometric Tolerance — Perfect Form at LMC**

in position is maximum when the feature is at MMC, unless a maximum is specified. See Figs. 7-14 and 7-15.

### 2.8.5 Effect of Zero Tolerance at LMC

Where a tolerance of position or orientation is applied on a zero tolerance at LMC basis, the tolerance is totally dependent on the size of the actual minimum material envelope of the considered feature. No tolerance of position or orientation is allowed if the feature is produced at its LMC limit of size; and in this case, it must be located at true position or be perfect in orientation, as applicable. Where the actual minimum material envelope of the considered feature has departed from LMC, a tolerance equal to the amount of such departure is allowed. The total permissible variation in position or orientation is maximum when the feature is at MMC unless a maximum is specified. See Figs. 6-15 and 7-14.

## 2.9 SCREW THREADS

Each tolerance of orientation or position and datum reference specified for a screw thread applies to the axis of the thread derived from the pitch cylinder. Where an exception to this practice is necessary, the specific feature of the screw thread (such as “MAJOR DIA” or “MINOR DIA”) shall be stated beneath the feature control frame, or beneath or adjacent to the datum feature symbol, as applicable. See Fig. 7-35.

## 2.10 GEARS AND SPLINES

Each tolerance of orientation or position and datum reference specified for features other than screw threads,

such as gears and splines, must designate the specific feature of the gear or spline to which each applies (such as “MAJOR DIA,” “PITCH DIA,” or “MINOR DIA”). This information is stated beneath the feature control frame or beneath the datum feature symbol, as applicable.

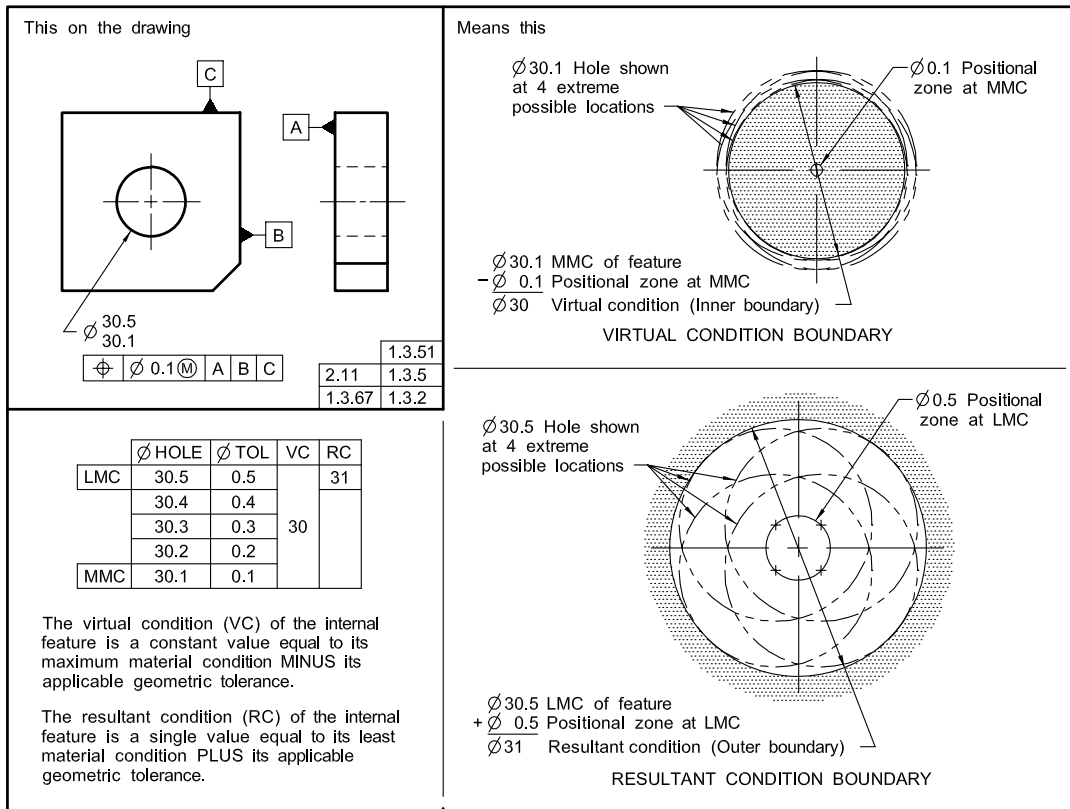
## 2.11 BOUNDARY CONDITIONS

Depending upon its function, a feature of size is controlled by its size and any applicable geometric tolerances. Material condition (RFS, MMC, or LMC) may also be applicable. Consideration must be given to the collective effects of MMC and applicable tolerances in determining the clearance between parts (fixed or floating fastener formula) and in establishing gage feature sizes. Consideration must be given to the collective effects of LMC and applicable tolerances in determining guaranteed area of contact, thin wall conservation, and alignment hole location in establishing gage feature sizes. Consideration must be given to the collective effects of RFS and any applicable tolerances in determining guaranteed control of the center point, feature axis, or feature center plane. See Figs. 2-12 through 2-17.

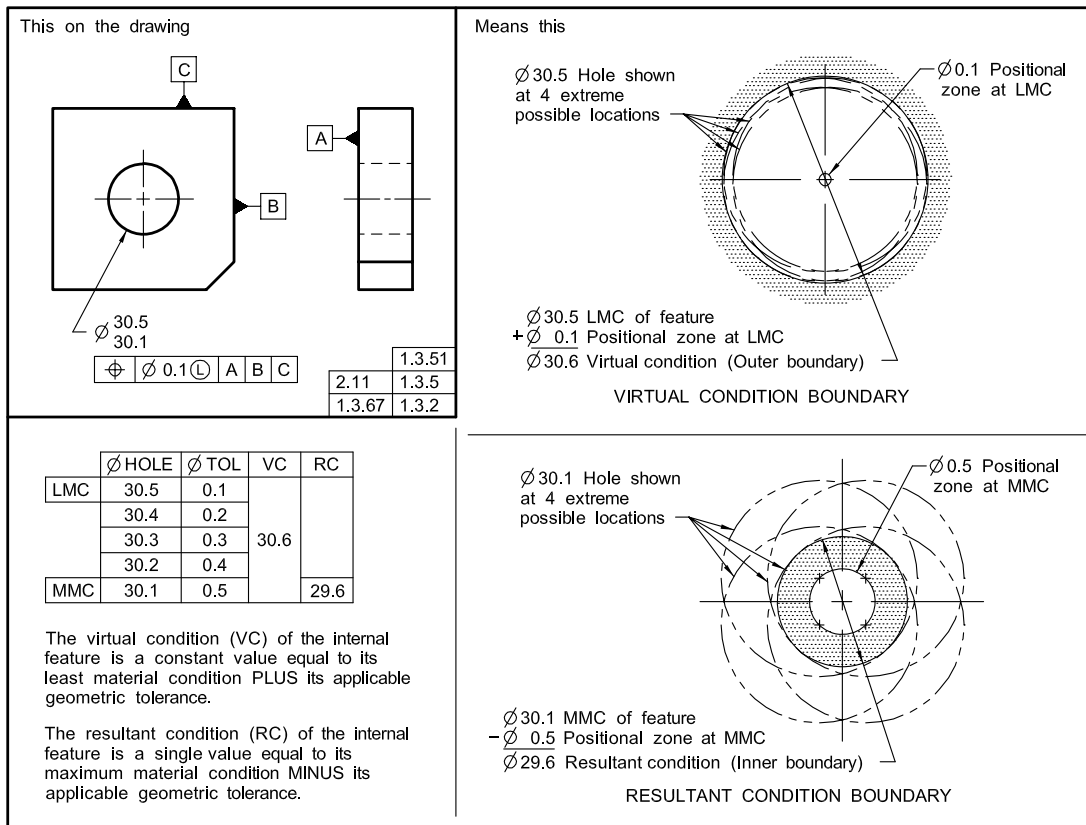
## 2.12 ANGULAR SURFACES

Where an angular surface is defined by a combination of a directly toleranced linear and an angular dimension, the surface must lie within a tolerance zone represented by two nonparallel planes. See Fig. 2-18. The tolerance zone will widen as the distance from the apex of the angle increases. Where a tolerance zone with parallel boundaries is desired, angularity or profile tolerance may be used. See Fig. 6-1 and Sections 6 and 8.

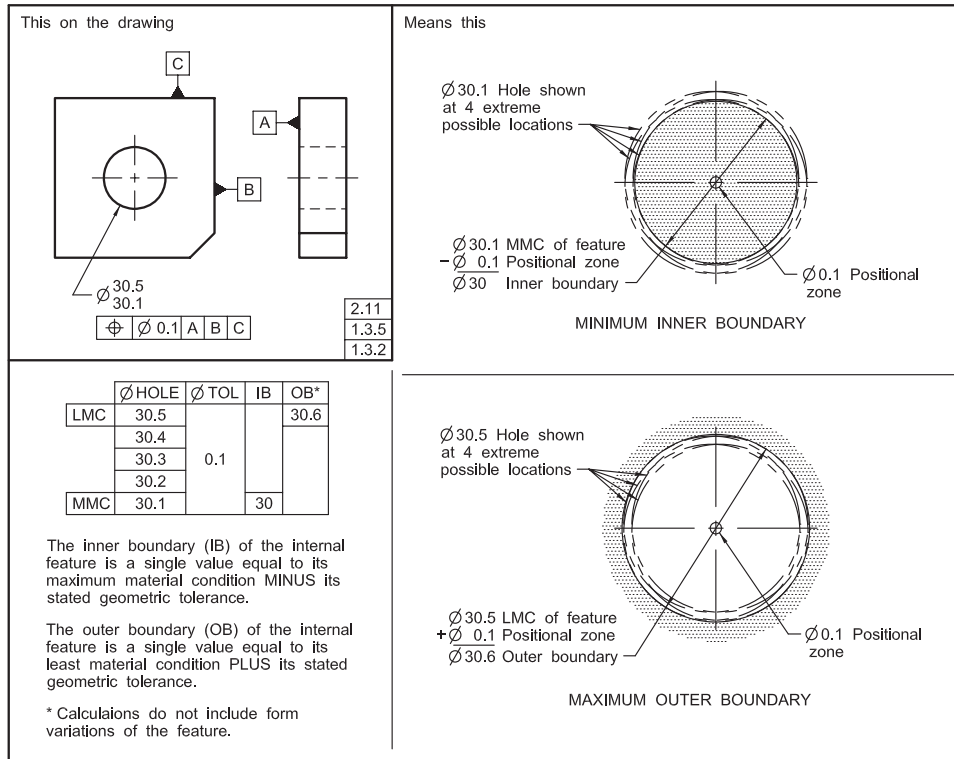
**Fig. 2-12 Virtual and Resultant Condition Boundaries Using MMC Concept — Internal Feature**



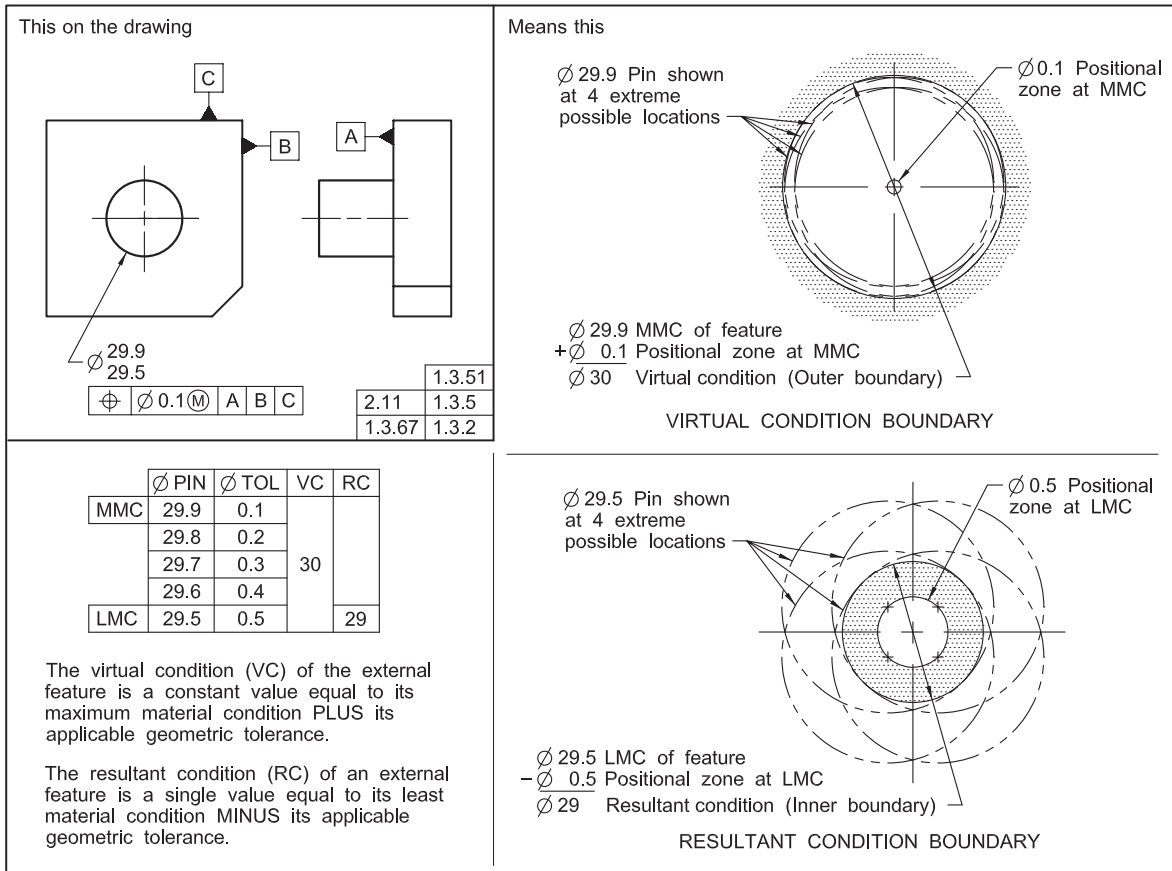
**Fig. 2-13 Virtual and Resultant Condition Boundaries Using LMC Concept — Internal Feature**



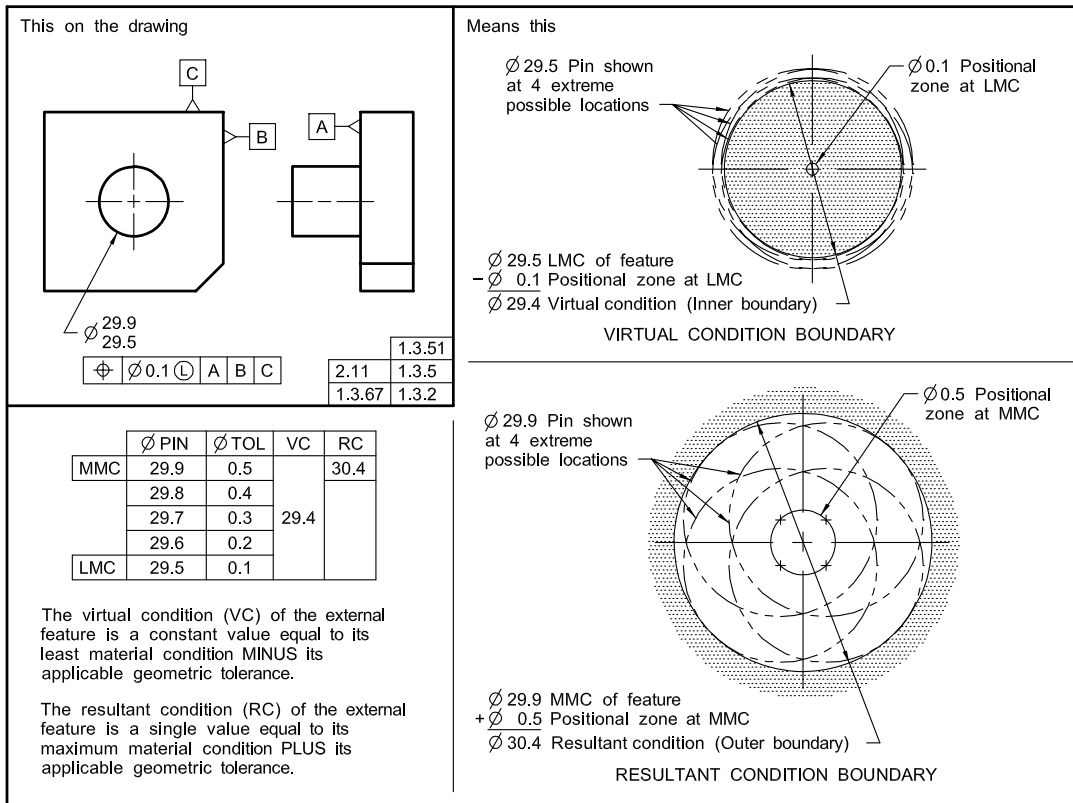
**Fig. 2-14 Inner and Outer Boundaries Using RFS Concept — Internal Feature**



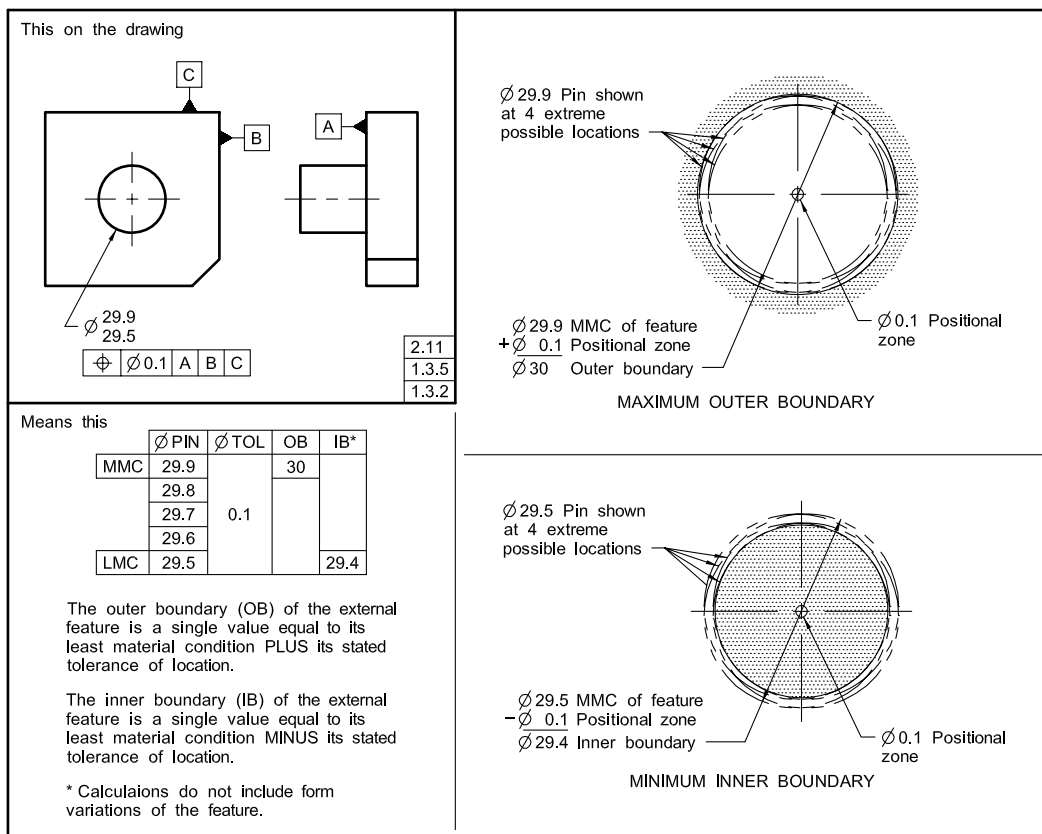
**Fig. 2-15 Virtual and Resultant Condition Boundaries Using MMC Concept — External Feature**



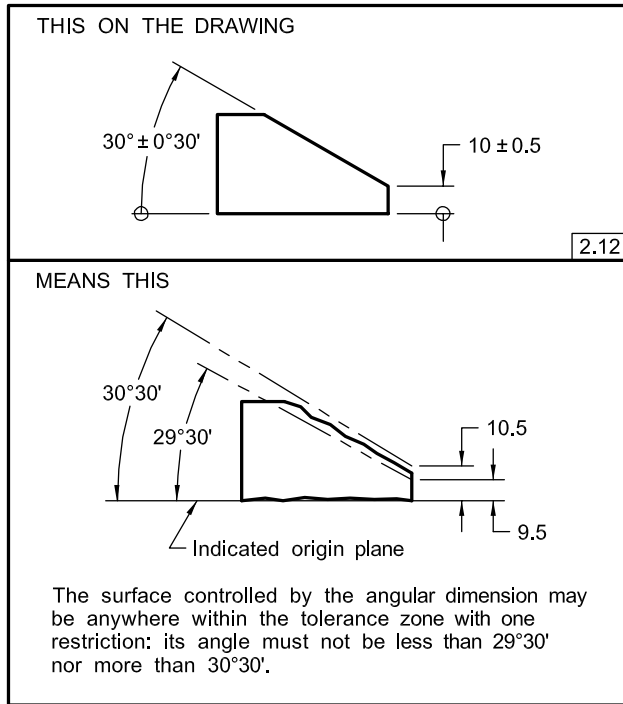
**Fig. 2-16 Virtual and Resultant Condition Boundaries Using LMC Concept – External Feature**



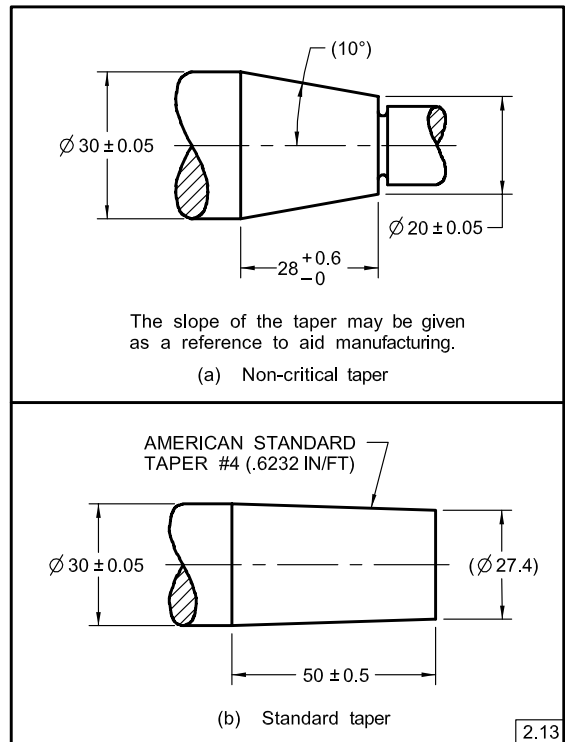
**Fig. 2-17 Inner and Outer Condition Boundaries Using RFS Concept – External Feature**



**Fig. 2-18 Tolerancing an Angular Surface Using a Combination of Linear and Angular Dimensions**



**Fig. 2-19 Specifying Tapers**



**2.13 CONICAL TAPERS**

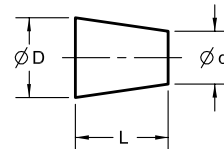
Conical tapers include the category of standard machine tapers used throughout the tooling industry, classified as American Standard Self-Holding and Steep Taper series. See ASME B5.10. American Standard machine tapers are usually dimensioned by specifying the taper name and number. See Fig. 2-19, illustration (b). The diameter at the gage line and the length may also be specified. The taper in inches per foot and the diameter of the small end may be shown as reference. A conical taper may also be specified by one of the following methods:

- (a) a basic taper and a basic diameter (see Fig. 2-21).
- (b) a size tolerance combined with a profile of a surface tolerance applied to the taper (see para. 8.4.2).
- (c) a toleranced diameter at both ends of a taper and a toleranced length. See Fig. 2-19, illustration (a).

NOTE: The method described in subpara. (c) is applicable for noncritical tapers, such as the transition between diameters of a shaft.

- (d) a composite profile tolerance.
- Conical taper is the ratio of the difference in the diameters of two sections (perpendicular to the axis) of a cone to the distance between these sections.

Thus, taper =  $(D - d) / L$ .

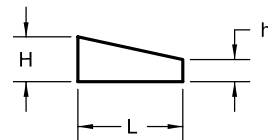


The symbol for a conical taper is shown in Fig. 2-21.

**2.14 FLAT TAPERS**

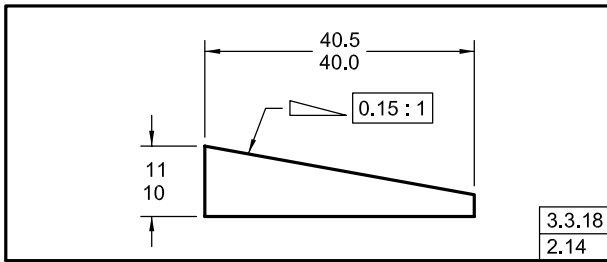
A flat taper may be specified by a toleranced slope and a toleranced height at one end. See Fig. 2-20. *Slope* may be specified as the inclination of a surface expressed as a ratio of the difference in the heights at each end (above and at right angles to a base line) to the distance between those heights.

Thus, slope =  $(H - h) / L$ .

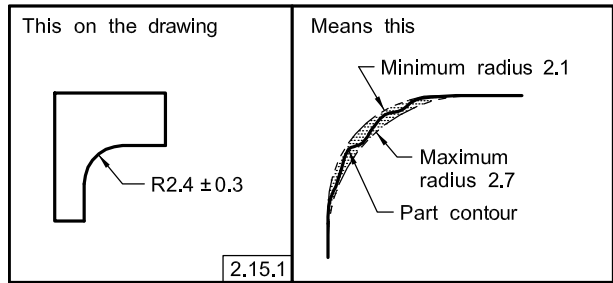


The symbol for slope is shown in Fig. 2-20.

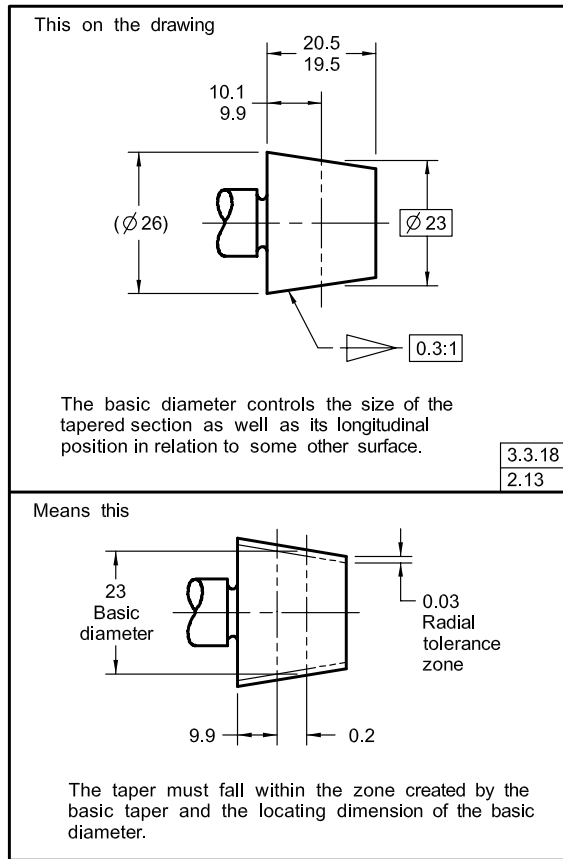
**Fig. 2-20 Specifying a Flat Taper**



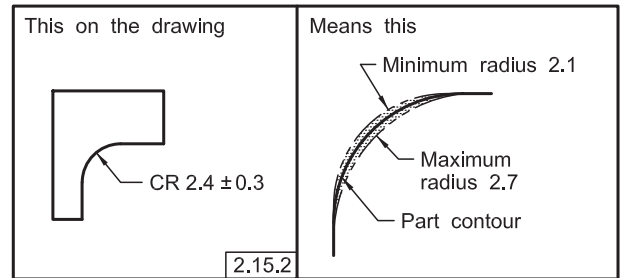
**Fig. 2-22 Specifying a Radius**



**Fig. 2-21 Specifying a Basic Taper and a Basic Diameter**



**Fig. 2-23 Specifying a Controlled Radius**



radii) that are tangent to the adjacent surfaces. Where a controlled radius is specified, the part contour within the crescent-shaped tolerance zone must be a fair curve without reversals. It is recommended that the CR be further defined with an engineering control specification. Additionally, radii taken at all points on the part contour shall neither be smaller than the specified minimum limit nor larger than the maximum limit. See Fig. 2-23. Where it is necessary to apply further restrictions to the part radius, they shall be specified on the drawing or in a document referenced on the drawing.

**2.15 RADIUS**

A radius is any straight line extending from the center to the periphery of a circle or sphere.

**2.15.1 Radius Tolerance**

A radius symbol, R, creates a zone defined by two arcs (the minimum and maximum radii). The part surface must lie within this zone. See Fig. 2-22.

**2.15.2 Controlled Radius Tolerance**

A controlled radius symbol, CR, creates a tolerance zone defined by two arcs (the minimum and maximum

**2.16 TANGENT PLANE**

Where it is desired to control a tangent plane established by the contacting points of a surface, the tangent plane symbol shall be added in the feature control frame after the stated tolerance. See Fig. 6-18. If the tangent plane is unstable it may be optimized. See para. 4.11.2 and ASME Y14.5.1M.

**2.17 STATISTICAL TOLERANCING**

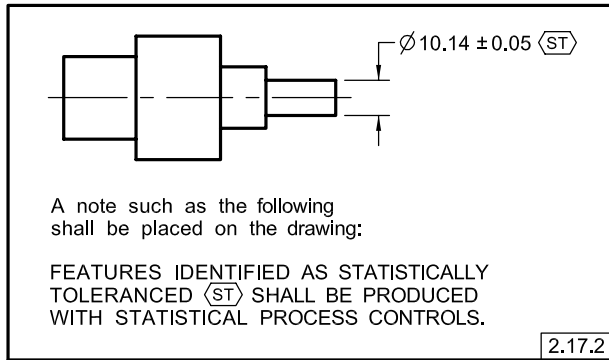
Statistical tolerancing is the assigning of tolerances to related components of an assembly on the basis of sound statistics (such as the assembly tolerance is equal to the square root of the sum of the squares of the individual tolerances).

**2.17.1 Application to Assemblies**

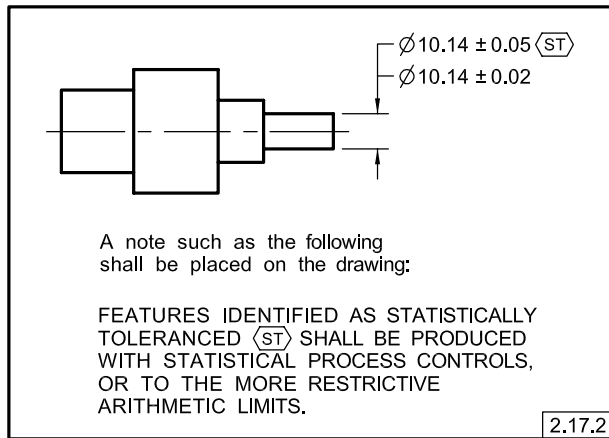
The tolerances assigned to component items of an assembly are determined by arithmetically dividing the



**Fig. 2-24 Statistical Tolerancing**



**Fig. 2-25 Statistical Tolerancing With Arithmetic Limits**



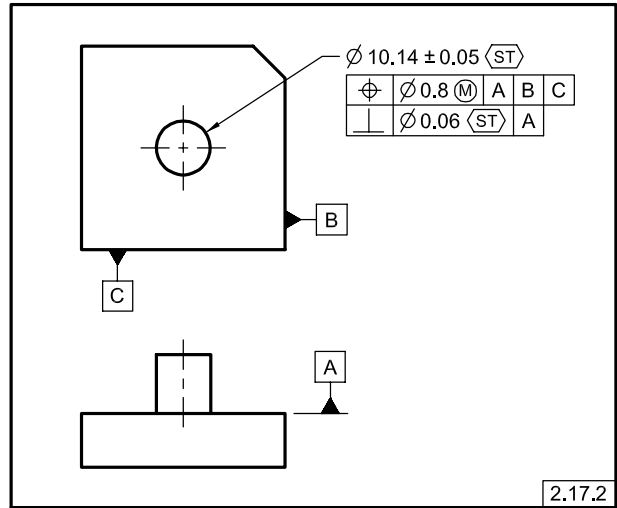
assembly tolerances among the individual components of the assembly. Where tolerances assigned by arithmetic stacking are restrictive, statistical tolerancing may be used for increased individual feature tolerance. The increased tolerance may reduce manufacturing cost, but shall only be employed where the appropriate statistical process control will be used. For application see appropriate statistics or engineering design manuals.

**2.17.2 Identification**

Statistical tolerances on dimensions are designated as illustrated in Figs. 2-24 through 2-26.

(a) A note such as the following shall be placed on the drawing: “FEATURES IDENTIFIED AS STATISTICALLY

**Fig. 2-26 Statistical Tolerancing With Geometric Controls**



TOLERANCED  $\langle ST \rangle$  SHALL BE PRODUCED WITH STATISTICAL PROCESS CONTROLS.” See Fig. 2-24.

(b) It may be necessary to designate both the statistical limits and the arithmetic stacking limits where the dimension has the possibility of being produced without statistical process control (SPC). A note such as the following shall be placed on the drawing: “FEATURES IDENTIFIED AS STATISTICALLY TOLERANCED  $\langle ST \rangle$  SHALL BE PRODUCED WITH STATISTICAL PROCESS CONTROLS, OR TO THE MORE RESTRICTIVE ARITHMETIC LIMITS.” See Fig. 2-25.

**CAUTION:** Where using the statistical tolerancing symbol, the necessary statistical indices should be specified.

## Section 3 Symbology

### 3.1 GENERAL

This Section establishes the symbols for specifying geometric characteristics and other dimensional requirements on engineering drawings. Symbols shall be of sufficient clarity to meet the legibility and reproducibility requirements of ASME Y14.2M. Symbols shall be used only as described herein.

### 3.2 USE OF NOTES TO SUPPLEMENT SYMBOLS

Situations may arise where the desired geometric requirements cannot be completely conveyed by symbology. In such cases, a note may be used to describe the requirement, either separately or to supplement a geometric symbol. See Figs. 6-16, 6-17, and 7-54.

### 3.3 SYMBOL CONSTRUCTION

Information related to the construction, form, and proportion of individual symbols described herein is contained in Nonmandatory Appendix C.

#### 3.3.1 Geometric Characteristic Symbols

The symbolic means of indicating geometric characteristics are shown in Fig. 3-1.

#### 3.3.2 Datum Feature Symbol

The symbolic means of indicating a datum feature consists of a capital letter enclosed in a square or rectangular frame and a leader line extending from the frame to the feature, terminating with a triangle. The triangle may be filled or not filled. See Fig. 3-2. Letters of the alphabet (except I, O, and Q) shall be used as datum identifying letters. Each datum feature of a part requiring identification shall be assigned a different letter. When datum features requiring identification on a drawing are so numerous as to exhaust the single alpha series, the double alpha series (AA through AZ, BA through BZ, etc.) shall be used and enclosed in a rectangular frame. Where the same datum feature symbol is repeated to identify the same feature in other locations of a drawing, it need not be identified as reference. The datum feature symbol is applied to the feature surface outline, extension line, dimension line, or feature control frame as follows:

(a) placed on the outline of a feature surface, on an extension line of the feature outline, clearly separated from the dimension line, when the datum feature is the

surface itself, or on a leader line directed to the surface. On 2D orthographic drawings where the datum feature is not on the visible surface, the leader line may be shown as a dashed line. See Fig. 3-3.

(b) placed on the dimension line or an extension of the dimension line of a feature of size when the datum is an axis or center plane. If there is insufficient space for the two arrows, one of them may be replaced by the datum feature triangle. See Figs. 3-4, illustrations (a) through (c), (f), and (h); 4-33; and 4-35, illustrations (c) and (d).

(c) placed on the outline of a cylindrical feature surface or an extension line of the feature outline, separated from the size dimension, when the datum is an axis. For digital data files, the triangle may be tangent to the feature. See Fig. 3-4, illustrations (e) and (g).

(d) placed on the horizontal portion of a dimension leader line for the size dimension. See Figs. 3-4, illustration (d); 4-33; and 4-35, illustrations (a) and (b).

(e) placed above or below and attached to the feature control frame. See para. 3.4.6 and Figs. 3-5 and 3-27.

(f) placed on a chain line that indicates a partial datum feature. See Fig. 4-27.

#### 3.3.3 Datum Target Symbol

The symbolic means of indicating a datum target shall be a circle divided horizontally into halves. The lower half contains a letter identifying the associated datum, followed by the target number assigned sequentially starting with 1 for each datum. See Figs. 3-6 and 4-48. A radial line attached to the symbol is directed to a target point, target line, or target area, as applicable. See para. 4.24.1. Where the datum target is an area, the size and shape of the area (true geometric counterpart) is entered in the upper half of the symbol; otherwise, the upper half is left blank. If there is not sufficient space within the compartment, the size and shape of the area may be placed outside and connected to the compartment by a leader line terminating with a dot. See Figs. 3-6 and 4-42.

**3.3.3.1 Datum Target Points.** A datum target point is indicated by the target point symbol, dimensionally located in a direct view of the surface. Where there is no direct view, the point location is dimensioned on two adjacent views. See Fig. 3-7.

**3.3.3.2 Datum Target Lines.** A datum target line is indicated by the datum target point symbol on an edge view of the surface, a phantom line on the direct view,

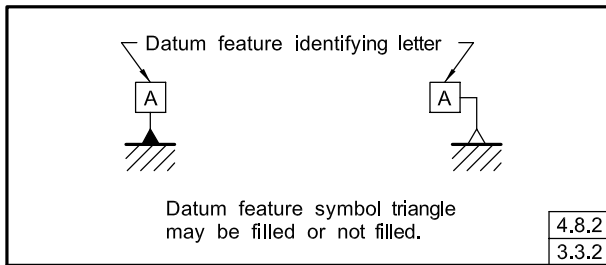
**Fig. 3-1 Geometric Characteristic Symbols**

APPLICATION	TYPE OF TOLERANCE	CHARACTERISTIC	SYMBOL	SEE:
INDIVIDUAL FEATURES	FORM	STRAIGHTNESS	—	5.4.1
		FLATNESS	▭	5.4.2
		CIRCULARITY	○	5.4.3
		CYLINDRICITY	∅	5.4.4
INDIVIDUAL OR RELATED FEATURES	PROFILE	PROFILE OF A LINE	⤿	8.2.1.2
		PROFILE OF A SURFACE	⤿	8.2.1.1
RELATED FEATURES	ORIENTATION	ANGULARITY	∠	6.3.1
		PERPENDICULARITY	⊥	6.3.3
		PARALLELISM	//	6.3.2
	LOCATION	POSITION **	⊕	7.2
		CONCENTRICITY	◎	7.6.4
		SYMMETRY	≡	7.7.2
	RUNOUT	CIRCULAR RUNOUT	↗*	9.4.1
TOTAL RUNOUT		↗*	9.4.2	

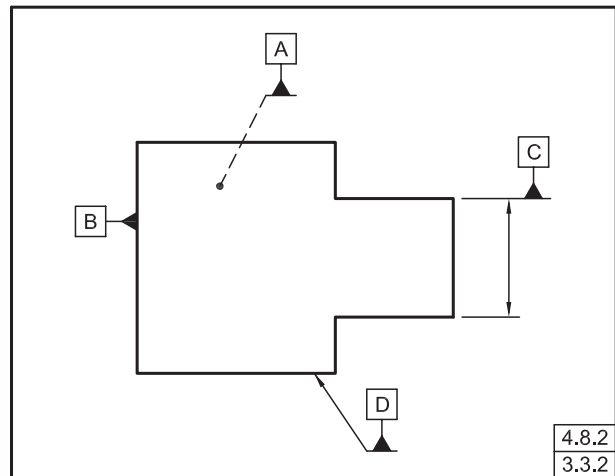
\* Arrowheads may be filled or not filled      \*\* May be related or unrelated

3.3.1

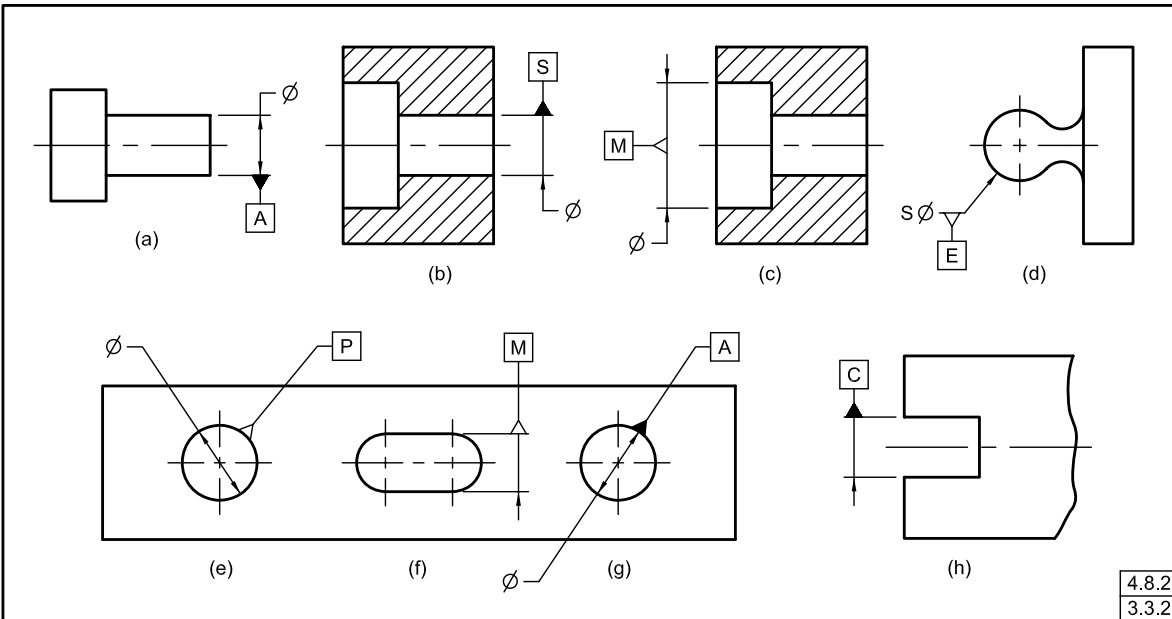
**Fig. 3-2 Datum Feature Symbol**



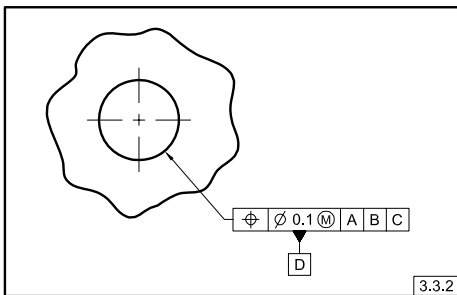
**Fig. 3-3 Datum Feature Symbols on a Feature Surface and an Extension Line**



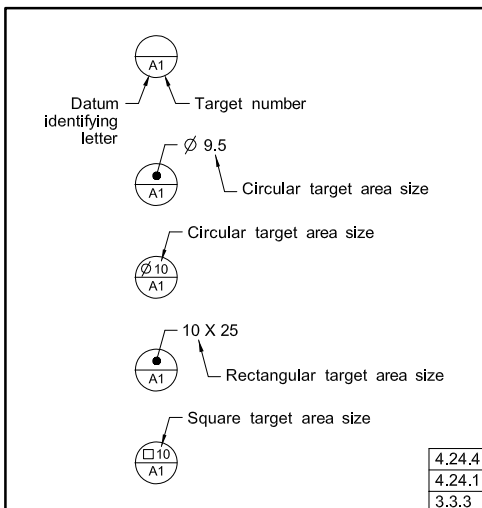
**Fig. 3-4 Placement of Datum Feature Symbols on Features of Size**



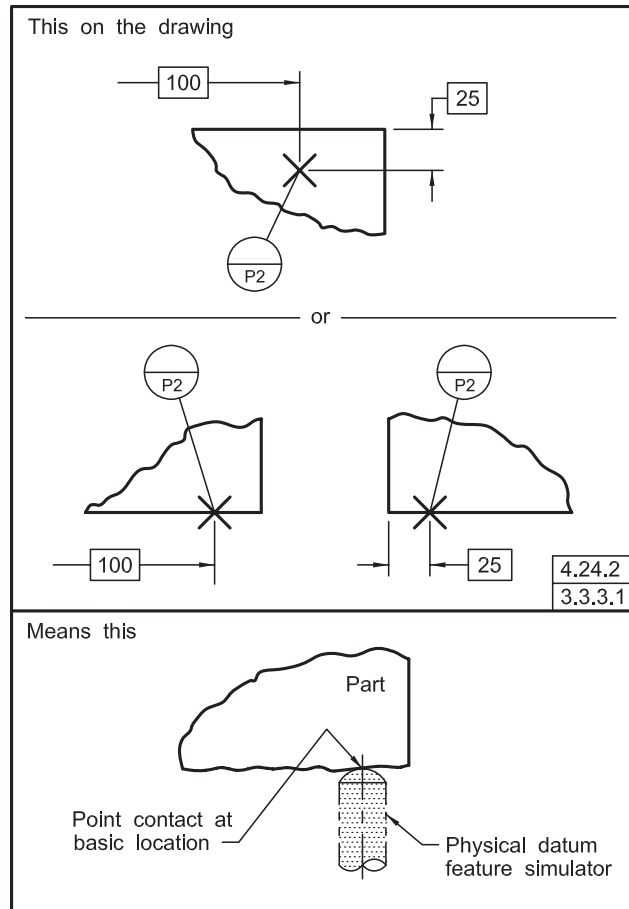
**Fig. 3-5 Placement of Datum Feature Symbol in Conjunction With a Feature Control Frame**



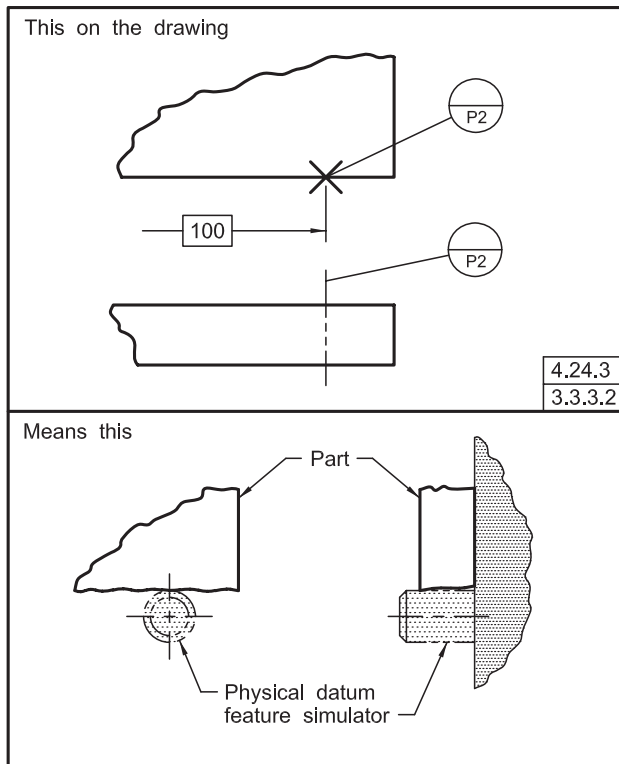
**Fig. 3-6 Datum Target Symbol Examples**



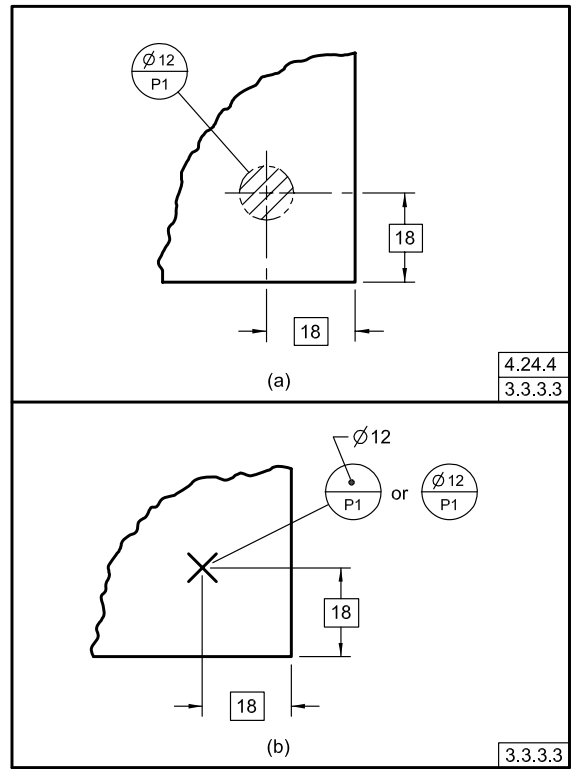
**Fig. 3-7 Datum Target Point**



**Fig. 3-8 Datum Target Line**



**Fig. 3-9 Datum Target Area**



or both. See Fig. 3-8. Where it is necessary to control the length of the datum target line, its length and location are dimensioned.

**3.3.3.3 Datum Target Areas.** Where it is determined that an area or areas of contact is necessary to assure establishment of the datum (that is, where spherical or pointed pins would be inadequate), a target area of the desired shape is specified. The datum target area is indicated by section lines inside a phantom outline of the desired shape, with controlling dimensions added. The diameter of circular areas is given in the upper half of the datum target symbol. See Fig. 3-9, illustration (a). Where it becomes impractical to delineate a circular target area, the method of indication shown in Fig. 3-9, illustration (b) may be used.

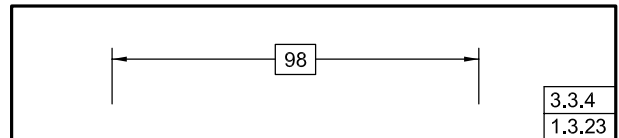
**3.3.4 Basic Dimension Symbol**

The symbolic means of indicating a basic dimension shall be as shown in Fig. 3-10.

**3.3.5 Material Condition/Boundary Symbols**

The symbolic means of indicating “at maximum material condition” or “at maximum material boundary,” “at least material condition” or “at least material boundary” shall be as shown in Figs. 3-11 and 4-5.

**Fig. 3-10 Basic Dimension Symbol Application**



**3.3.6 Projected Tolerance Zone Symbol**

The symbolic means of indicating a projected tolerance zone shall be as shown in Figs. 3-11, 7-21, and 7-22.

**3.3.7 Diameter and Radius Symbols**

The symbols used to indicate diameter, spherical diameter, radius, spherical radius, and controlled radius shall be as shown in Fig. 3-11. These symbols shall precede the value of a dimension or tolerance given as a diameter or radius, as applicable. The symbol and the value shall not be separated by a space.

**3.3.8 Reference Symbol**

The symbolic means of indicating a dimension or other dimensional data as reference shall be by enclosing the dimension (or dimensional data) within parentheses. See Figs. 2-3 and 3-11. In written notes, parentheses retain their grammatical interpretation unless otherwise

**Fig. 3-11 Modifying Symbols**

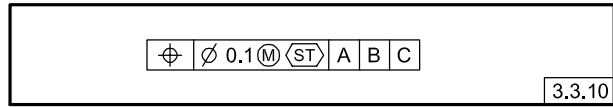
TERM	SYMBOL	SEE:
AT MAXIMUM MATERIAL CONDITION (When applied to a tolerance value) AT MAXIMUM MATERIAL BOUNDARY (When applied to a datum reference)		3.3.5
AT LEAST MATERIAL CONDITION (When applied to a tolerance value) AT LEAST MATERIAL BOUNDARY (When applied to a datum reference)		3.3.5
TRANSLATION		3.3.26
PROJECTED TOLERANCE ZONE		3.3.6
FREE STATE		3.3.20
TANGENT PLANE		3.3.21
UNEQUALLY DISPOSED PROFILE		3.3.22
INDEPENDENCY		3.3.24
STATISTICAL TOLERANCE		3.3.10
CONTINUOUS FEATURE		3.3.23
DIAMETER		3.3.7
SPHERICAL DIAMETER		3.3.7
RADIUS	<b>R</b>	3.3.7
SPHERICAL RADIUS	<b>SR</b>	3.3.7
CONTROLLED RADIUS	<b>CR</b>	3.3.7
SQUARE		3.3.16
REFERENCE	<b>( )</b>	3.3.8
ARC LENGTH		3.3.9
DIMENSION ORIGIN		3.3.17
BETWEEN		3.3.11
ALL AROUND		3.3.19
ALL OVER		3.3.25

specified. When it is necessary to define dimensions or dimensional data as reference in a note, the term “REFERENCE” or abbreviation “REF” shall be used.

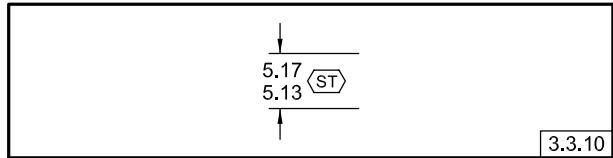
**3.3.9 Arc Length Symbol**

The symbolic means of indicating that a dimension is an arc length measured on a curved outline shall be as shown in Fig. 3-11. The symbol shall be placed above the dimension and applies to the surface nearest the dimension.

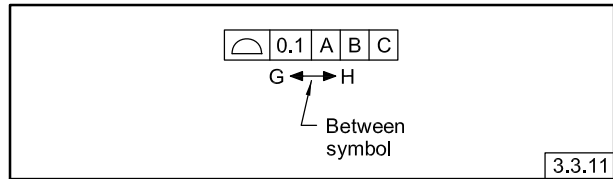
**Fig. 3-12 Indicating the Specified Tolerance is a Statistical Geometric Tolerance**



**Fig. 3-13 Statistical Tolerance Symbol**



**Fig. 3-14 Between Symbol**



**3.3.10 Statistical Tolerancing Symbol**

The symbolic means of indicating that a tolerance is based on statistical tolerancing shall be as shown in Fig. 3-11. If the tolerance is a statistical geometric tolerance, the symbol shall be placed in the feature control frame following the stated tolerance and any modifier. See Fig. 3-12. If the tolerance is a statistical size tolerance, the symbol shall be placed adjacent to the size dimension. See Fig. 3-13.

**3.3.11 Between Symbol**

The symbolic means of indicating that a tolerance or other specification apply across multiple features or to a limited segment of a feature between designated extremities is shown in Figs. 3-11, 3-14, 8-6, and 8-7. The leader from the feature control frame is directed to the portion of the feature to which that tolerance applies. In Fig. 3-14, for example, the tolerance applies only between G and H. G and H may be points, lines, or features.

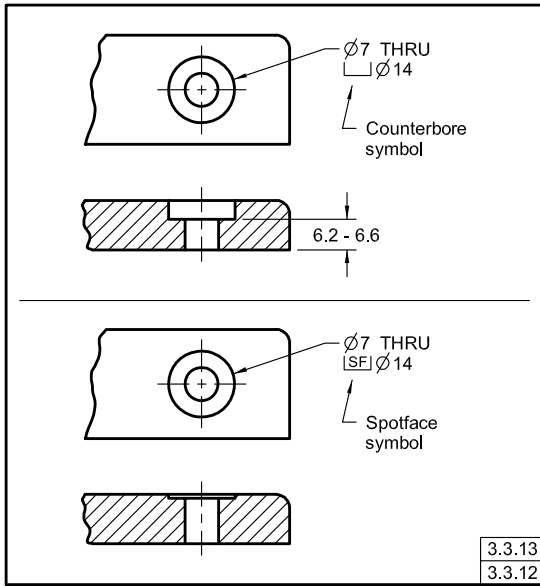
**3.3.12 Counterbore Symbol**

The symbolic means of indicating a counterbore shall be as shown in Figs. 1-37 and 3-15. The symbol shall precede, with no space, the dimension of the counterbore.

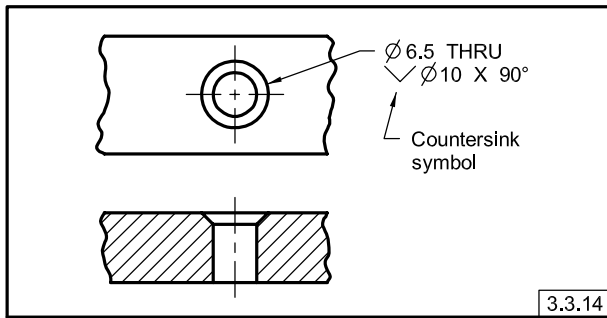
**3.3.13 Spotface Symbol**

The symbolic means of indicating a spotface shall be as shown in Figs. 1-41 and 3-15. The symbol shall precede, with no space, the dimension of the spotface.

**Fig. 3-15 Counterbore or Spotface Symbol**



**Fig. 3-16 Countersink Symbol**



**3.3.14 Countersink Symbol**

The symbolic means of indicating a countersink shall be as shown in Fig. 3-16. The symbol shall precede, with no space, the dimensions of the countersink.

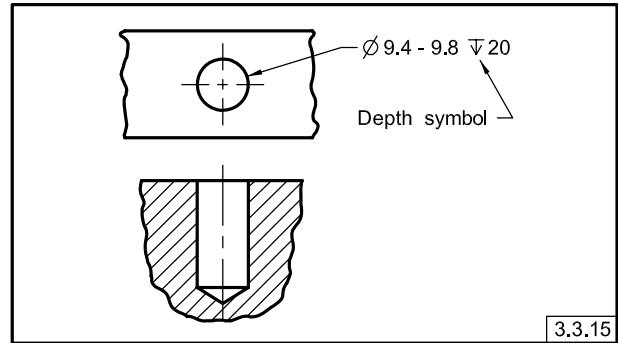
**3.3.15 Depth Symbol**

The symbolic means of indicating that a dimension applies to the depth of a feature is to precede that dimension with the depth symbol, as shown in Fig. 3-17. The symbol and the value are not separated by a space.

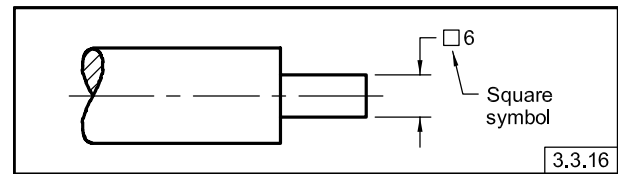
**3.3.16 Square Symbol**

The symbolic means of indicating that a single dimension applies to a square shape shall be to precede that dimension with the square symbol, as shown in Figs. 3-11 and 3-18. The symbol and the value shall not be separated by a space.

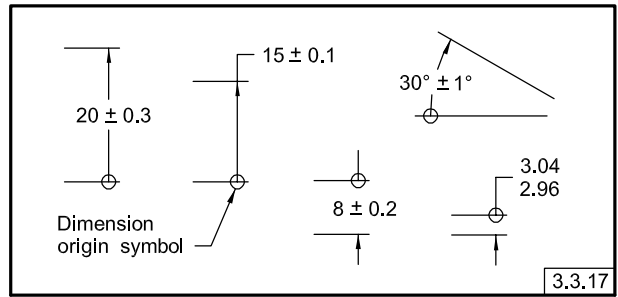
**Fig. 3-17 Depth Symbol**



**Fig. 3-18 Square Symbol**



**Fig. 3-19 Dimension Origin Symbol**



**3.3.17 Dimension Origin Symbol**

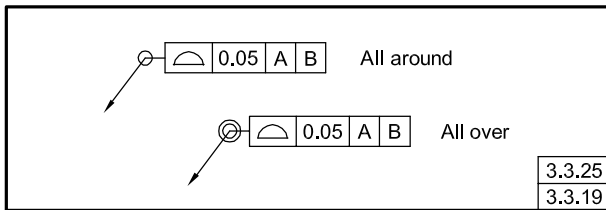
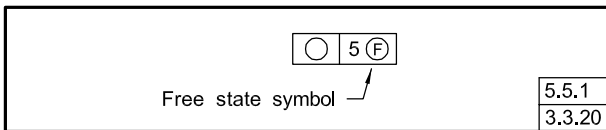
The symbolic means of indicating that a tolerated dimension between two features originates from one of these features and not the other shall be as shown in Figs. 2-5, 3-11, and 3-19.

**3.3.18 Taper and Slope Symbols**

The symbolic means of indicating taper and slope for conical and flat tapers shall be as shown in Figs. 2-20 and 2-21. These symbols shall be shown with the vertical leg to the left.

**3.3.19 All Around Symbol**

The symbolic means of indicating that a profile tolerance applies to surfaces all around the true profile in the view shown is a circle located at the junction of the leader from the feature control frame. See Figs. 3-11, 3-20, and 8-12.

**Fig. 3-20 All Over and All Around Symbols Applications****Fig. 3-21 Feature Control Frame With Free State Symbol**

### 3.3.20 Free-State Symbol

For features or datum feature references subject to free-state variation as defined in para. 5.5, the symbolic means of indicating that the geometric tolerance or datum feature applies in its “free state” is shown in Figs. 3-1 and 3-21. When the symbol is applied to a tolerance in the feature control frame, it shall follow the stated tolerance and any modifier. When the symbol is applied to a datum feature reference, it shall follow that datum feature reference and any modifier.

### 3.3.21 Tangent Plane Symbol

The symbolic means of indicating a tangent plane shall be as shown in Fig. 3-11. The symbol shall be placed in the feature control frame following the stated tolerance as shown in Fig. 6-18. Also, see paras. 1.3.45 and 6.5.

### 3.3.22 Unequally Disposed Profile Symbol

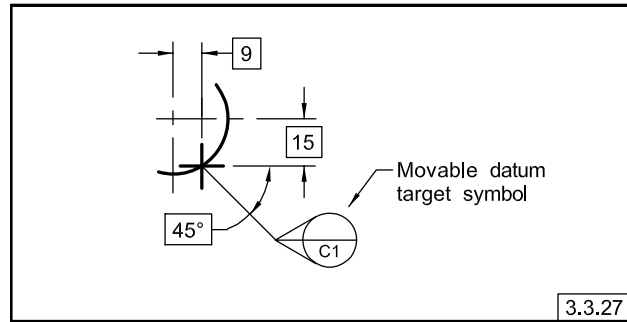
This symbol indicates a unilateral or unequally disposed profile tolerance. The symbol shall be placed in the feature control frame following the tolerance value as shown in Figs. 3-11 and 8-1 through 8-3 and para. 8.3.1.2.

### 3.3.23 Continuous Feature Symbol

This symbol indicates a group of two or more interrupted features as a single feature. See Figs. 2-8 through 2-10 and 3-11 and para. 2.7.5.

### 3.3.24 Independency Symbol

This symbol indicates that perfect form of a feature of size at MMC or at LMC is not required. The symbol shall

**Fig. 3-22 Movable Datum Target Symbol Application**

be placed next to the appropriate dimension or notation. See Fig. 3-11 and para. 2.7.3.

### 3.3.25 All-Over Symbol

This symbol indicates that a profile tolerance or other specification shall apply all over the three-dimensional profile of a part. See Figs. 3-11, 3-20, and 8-8 and para. 8.3.1.6.

### 3.3.26 Datum Translation Symbol

This symbol indicates that a datum feature simulator is not fixed at its basic location and shall be free to translate. See Figs. 3-11, 4-19, and 4-32, illustration (b), and para. 4.11.10.

### 3.3.27 Movable Datum Target Symbol

This symbol indicates that a datum target is not fixed at its basic location and is free to translate. See Figs. 3-22, 4-47, and 4-49 and para. 4.24.6.

### 3.3.28 Surface Texture Symbols

For information on the symbolic means of specifying surface texture, see ASME Y14.36M.

### 3.3.29 Symbols for Limits and Fits

For information on the symbolic means of specifying metric limits and fits, see para. 2.2.1.

### 3.3.30 Datum Reference Frame Symbol

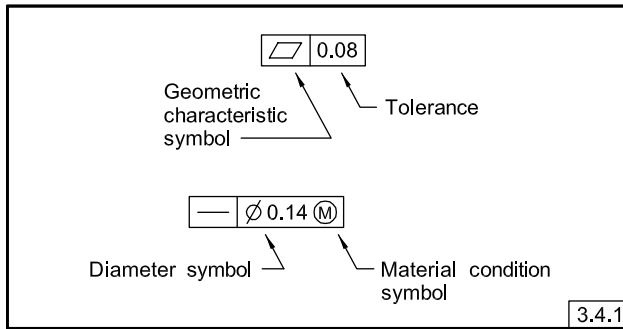
The datum reference frame symbol shall consist of the X, Y, and Z coordinate labels applied to the axes of the datum reference frame. See Figs. 4-1 and 4-2.

## 3.4 FEATURE CONTROL FRAME SYMBOLS

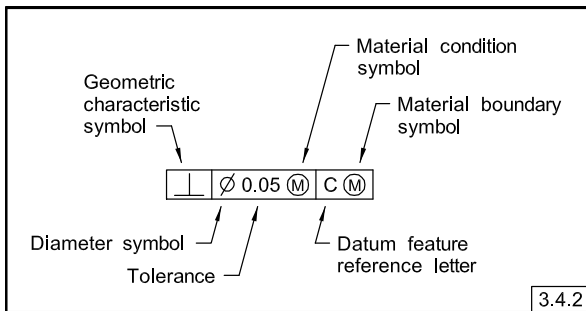
Geometric characteristic symbols, the tolerance value, modifiers, and datum feature reference letters, where applicable, are combined in a feature control frame to express a geometric tolerance.



**Fig. 3-23 Feature Control Frame**



**Fig. 3-24 Feature Control Frame Incorporating a Datum Feature Reference**



**3.4.1 Feature Control Frame**

A feature control frame is a rectangle divided into compartments containing the geometric characteristic symbol followed by the tolerance value or description, modifiers, and any applicable datum feature references. See Figs. 3-23, 4-2, and 7-4. Where applicable, the tolerance is preceded by the diameter or spherical diameter symbol and followed by a material condition modifier.

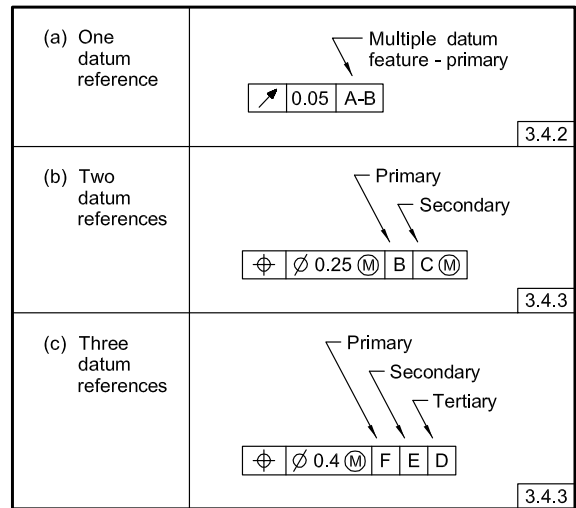
**3.4.2 Feature Control Frame Incorporating One Datum Feature Reference**

Where a geometric tolerance is related to a datum, this relationship is indicated by entering the datum feature reference letter in a compartment following the tolerance. Where applicable, the datum feature reference letter is followed by a material boundary modifier. See Fig. 3-24. Where a datum is established by two or more datum features (e.g., an axis established by two datum features) all datum feature reference letters, separated by a dash, are entered in a single compartment. Where applicable, each datum feature reference letter is followed by a material boundary modifier. See Figs. 3-25, illustration (a), and 4-25 and para. 4.12.2.

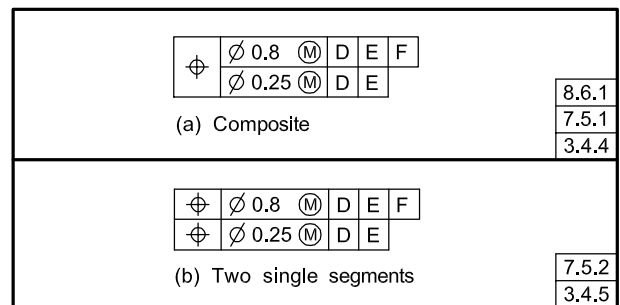
**3.4.3 Feature Control Frame Incorporating Two or Three Datum Feature References**

Where more than one datum is required, the datum feature reference letters (each followed by a material

**Fig. 3-25 Order of Precedence of Datum Reference**



**Fig. 3-26 Multiple Feature Control Frames**



boundary modifier, where applicable) are entered in separate compartments in the desired order of precedence, from left to right. See Fig. 3-25, illustrations (b) and (c). Datum feature reference letters need not be in alphabetical order in the feature control frame.

**3.4.4 Composite Feature Control Frame**

A composite feature control frame contains a single entry of a geometric characteristic symbol (position or profile) followed by each tolerance and datum requirement, one above the other. See Fig. 3-26, illustration (a), and paras. 7.5.1 and 8.6.

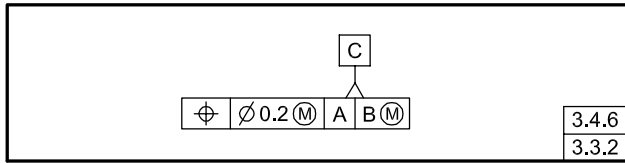
**3.4.5 Two Single-Segment Feature Control Frames**

The symbolic means of representing two single-segment feature control frames shall be as shown in Fig. 3-26, illustration (b). Application of this control is described in para. 7.5.2.

**3.4.6 Combined Feature Control Frame and Datum Feature Symbol**

Where a feature or pattern of features controlled by a geometric tolerance also serves as a datum feature, the

**Fig. 3-27 Combined Feature Control Frame and Datum Feature Symbol**



feature control frame and datum feature symbol may be combined. The datum feature symbol may be attached to the feature control frame. See Fig. 3-27. In the positional tolerance example in Fig. 3-27, a feature is controlled for position in relation to datums A and B, and identified as datum feature C.

**3.4.7 Feature Control Frame With a Projected Tolerance Zone**

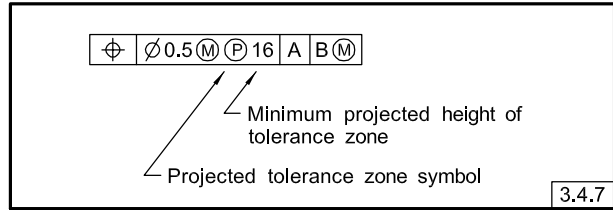
Where a positional or an orientation tolerance is specified as a projected tolerance zone, the projected tolerance zone symbol shall be placed in the feature control frame, along with the dimension indicating the minimum height of the tolerance zone. This shall follow the stated tolerance and any modifier. See Figs. 3-28 and 7-21. Where necessary for clarification, the projected tolerance zone shall be indicated with a chain line, and the minimum height of the tolerance zone is specified in a drawing view. The height dimension may then be omitted from the feature control frame. See Fig. 7-22.

**3.5 FEATURE CONTROL FRAME PLACEMENT**

A feature control frame is related to a considered feature by one of the following methods and as depicted in Fig. 3-29:

- (a) locating the frame below or attached to a leader-directed note or dimension pertaining to the feature

**Fig. 3-28 Feature Control Frame With a Projected Tolerance Zone Symbol**



- (b) attaching a leader from the frame pointing to the feature

- (c) attaching a side, corner, or an end of the frame to an extension line from the feature, provided it is a plane surface

- (d) attaching a side, corner, or an end of the frame to an extension of the dimension line pertaining to a feature of size

- (e) placing in a note, chart, or the general tolerance block

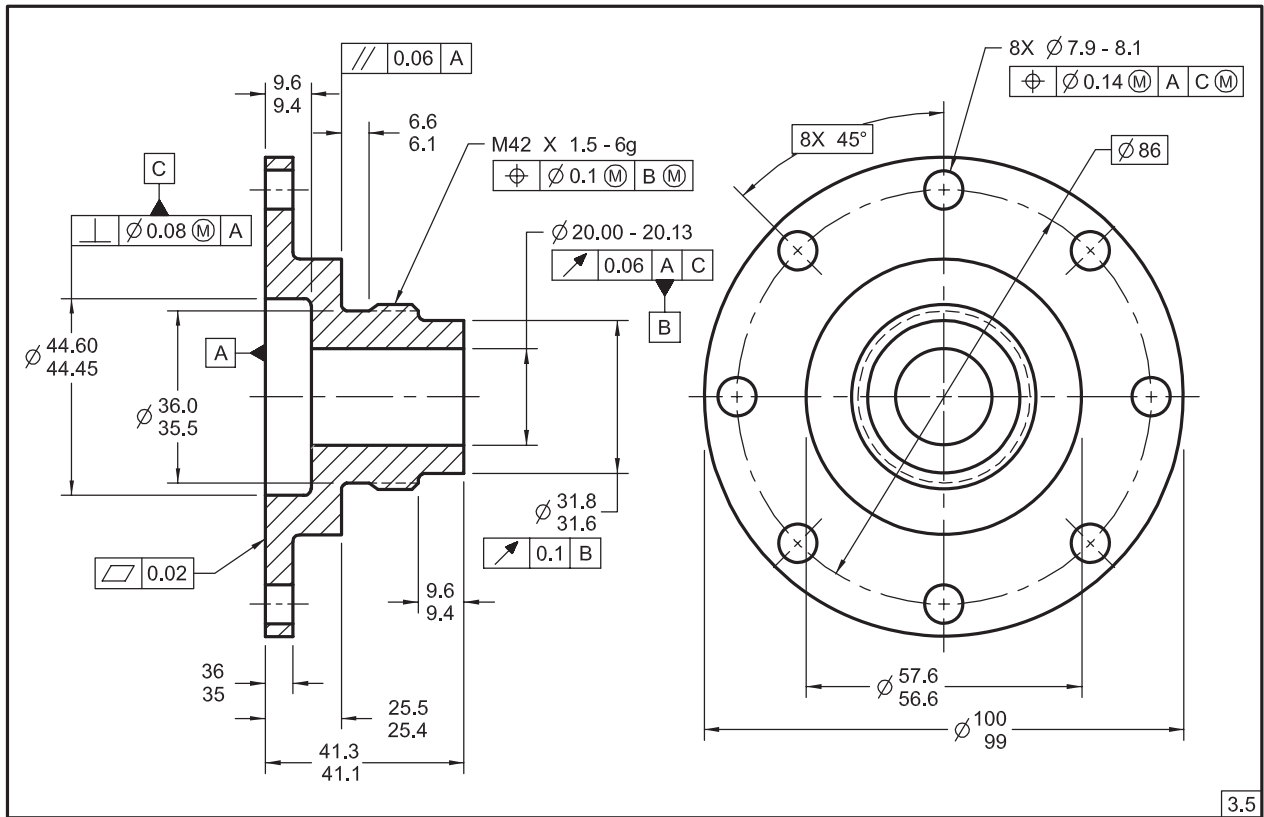
**3.6 DEFINITION OF THE TOLERANCE ZONE**

Where the specified tolerance value represents the diameter of a cylindrical or spherical zone, the diameter or spherical diameter symbol shall precede the tolerance value. Where the tolerance zone is other than a diameter, the diameter symbol shall be omitted, and the specified tolerance value represents the distance between two parallel straight lines or planes, or the distance between two uniform boundaries, as the specific case may be. In some cases the tolerance zone is nonuniform and is specified as described in para. 8.3.2.

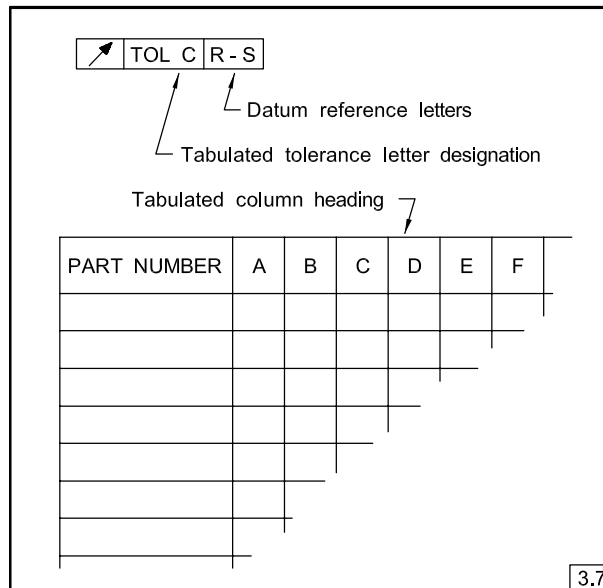
**3.7 TABULATED TOLERANCES**

Where the tolerance in a feature control frame is tabulated, a letter representing the tolerance, preceded by the abbreviation TOL, shall be entered as shown in Fig. 3-30.

**Fig. 3-29 Feature Control Frame Placement**



**Fig. 3-30 Tabulated Tolerances**



## Section 4

# Datum Reference Frames

### 4.1 GENERAL

This Section establishes the principles of identifying features as datum features for establishing relationships imposed by geometric tolerances and for constraining degrees of freedom. This Section also establishes the criteria for establishing datums and the datum reference frame using datum feature simulators derived from datum features. Datums are theoretically exact points, axes, lines, and planes. A datum reference frame is three mutually perpendicular intersecting datum planes. See Fig. 4-1.

NOTE: Whenever the term “datum feature simulator” is used in this Standard, it refers to the theoretical, unless specifically otherwise indicated.

### 4.2 DEGREES OF FREEDOM

All parts have six degrees of freedom, three translational and three rotational, which may be constrained by datum feature references in a feature control frame. The three translational degrees of freedom are termed X, Y, and Z. The three rotational degrees of freedom are termed u, v, and w. See Figs. 4-1, 4-2, illustration (c); 4-2, illustration (d); and 4-2, illustration (e).

NOTE: In the means this portion of some figures in this Standard, the translational and rotational degrees of freedom are annotated such as in Figs. 4-1, 4-2, 4-3, and 4-44 to aid the user in interpretation of the drawing.

### 4.3 DEGREES OF FREEDOM CONSTRAINED BY PRIMARY DATUM FEATURES REGARDLESS OF MATERIAL BOUNDARY

The relationship between the primary datum feature and its datum feature simulator constrains the degrees of freedom according to the material boundary condition applied to the datum feature in the feature control frame. The datum feature simulator restricts the movement of the datum feature and establishes the datum(s). See Fig. 4-3 for some examples of degrees of freedom constrained by primary datum features regardless of material boundary (RMB). Although collections of features may be used to establish a single datum, for simplicity, the chart in Fig. 4-3 illustrates only single datum features. The degrees of freedom constrained depend on whether the datum feature is referenced as a primary, a secondary, or a tertiary datum feature. See Figs. 4-2,

4-8, and 4-12. The following primary datums are derived from the associated datum feature simulator:

(a) a planar datum feature (nominally flat) establishes a datum feature simulator that creates a datum plane and constrains three degrees of freedom (one translation and two rotations). See Fig. 4-3, illustration (a).

(b) a width as a datum feature (two opposed parallel surfaces) establishes a datum feature simulator that creates a datum center plane and constrains three degrees of freedom (one translation and two rotations). See Fig. 4-3, illustration (b).

(c) a spherical datum feature establishes a datum feature simulator that creates a datum center point and constrains three translational degrees of freedom. See Fig. 4-3, illustration (c).

(d) a cylindrical datum feature establishes a datum feature simulator that creates a datum axis (line) and constrains four degrees of freedom (two translations and two rotations). See Fig. 4-3, illustration (d).

(e) a conical shaped datum feature establishes a datum feature simulator that creates a datum axis and a datum point and constrains five degrees of freedom (three translations and two rotations). See Fig. 4-3, illustration (e).

(f) a datum feature of linear extruded shape establishes a datum feature simulator that creates a datum plane and a datum axis and constrains five degrees of freedom (two translations and three rotations). See Fig. 4-3, illustration (f).

(g) a complex datum feature establishes a datum feature simulator that creates a datum plane, datum point, and a datum axis and constrains six degrees of freedom (three translations and three rotations). See Fig. 4-3, illustration (g).

### 4.4 CONSTRAINING DEGREES OF FREEDOM OF A PART

Where datum features are referenced in a feature control frame, the part is constrained in rotation and translation relative to the applicable datum feature simulators in the specified order of precedence with applicable modifiers that establish the datum reference frame. This defines the geometric relationships that exist between the geometric tolerance zones and the datum reference frame. See Figs. 4-2, 4-5, 4-6, and 4-9. Datum feature simulators are used to associate the datum features and the datums. This constrains the motion (degrees of freedom) between the part and the associated datum reference frame.

Fig. 4-1 Datum Reference Frame

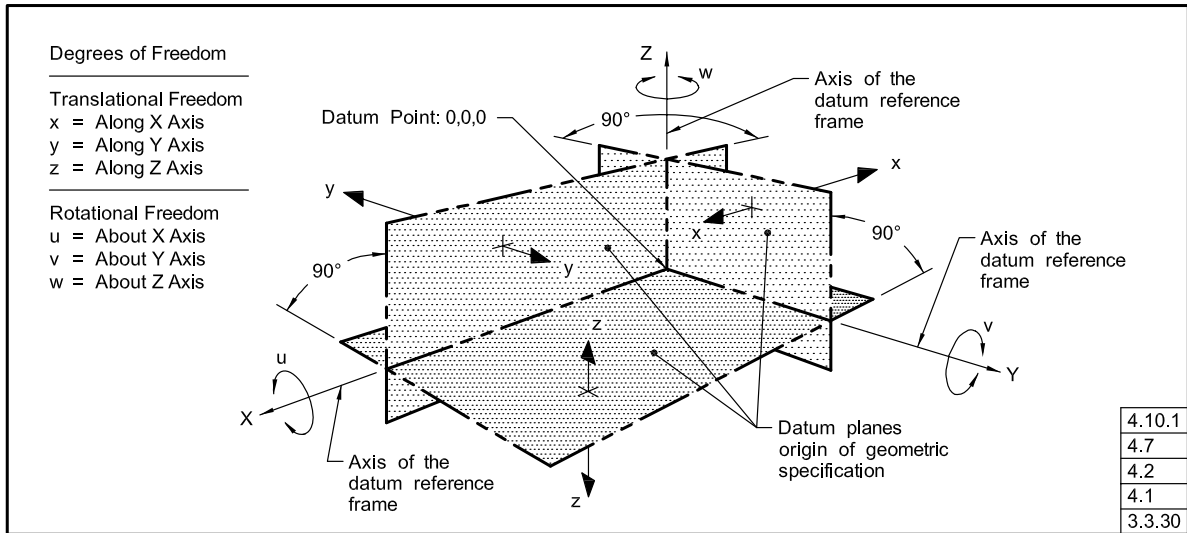
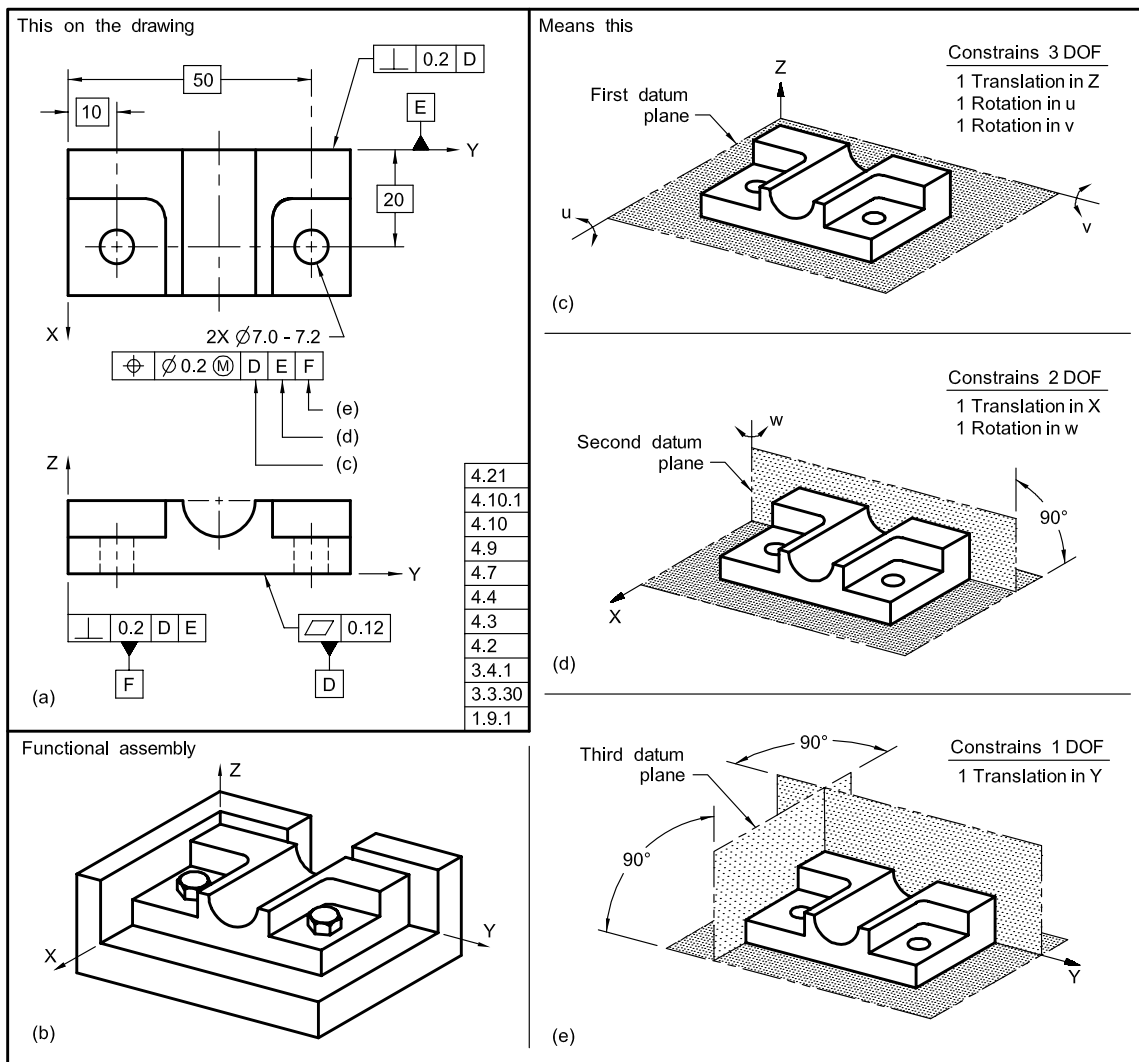


Fig. 4-2 Sequence of Datum Features Relates Part to Datum Reference Frame



**Fig. 4-3 Constrained Degrees of Freedom for Primary Datum Features**

FEATURE TYPE	ON THE DRAWING	DATUM FEATURE	DATUM AND DATUM FEATURE SIMULATOR	DATUM AND CONSTRAINING DEGREES OF FREEDOM
PLANAR (a)			 PLANE	
WIDTH (b)			 CENTER PLANE	
SPHERICAL (c)			 POINT	
CYLINDRICAL (d)			 AXIS	
CONICAL (e)			 AXIS & POINT	
LINEAR EXTRUDED SHAPE (f)			 AXIS & CENTER PLANE	
COMPLEX (g)			 AXIS, POINT, & CENTER PLANE	 4.23 4.3 4.11.4 4.2

Fig. 4-4 Multiple Datum Reference Frames and Their Interrelationships

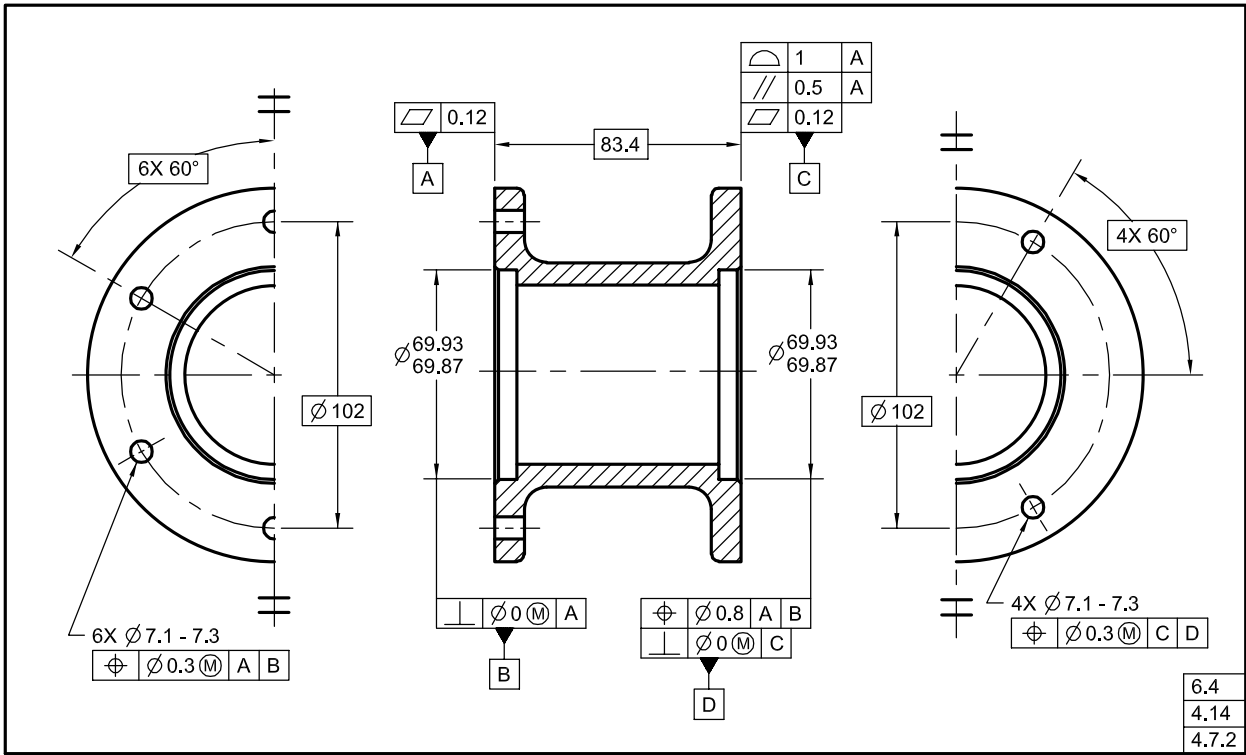
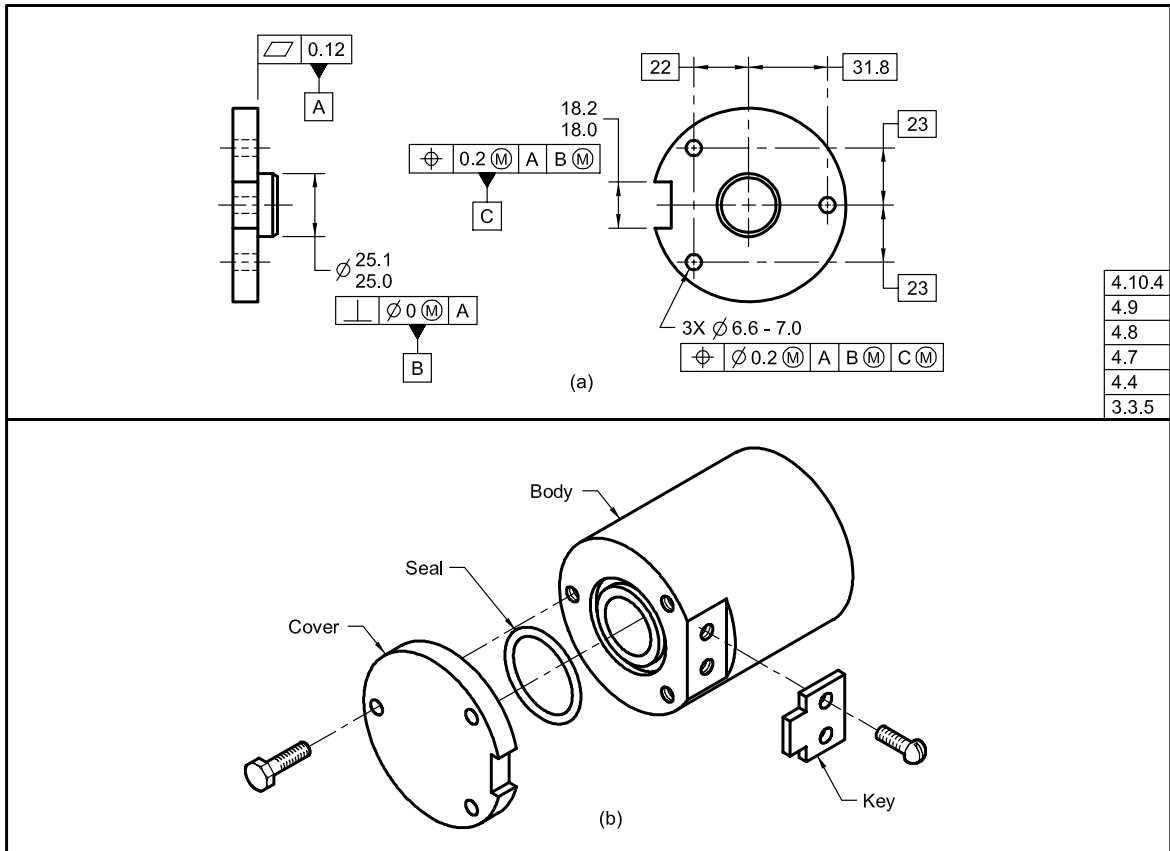
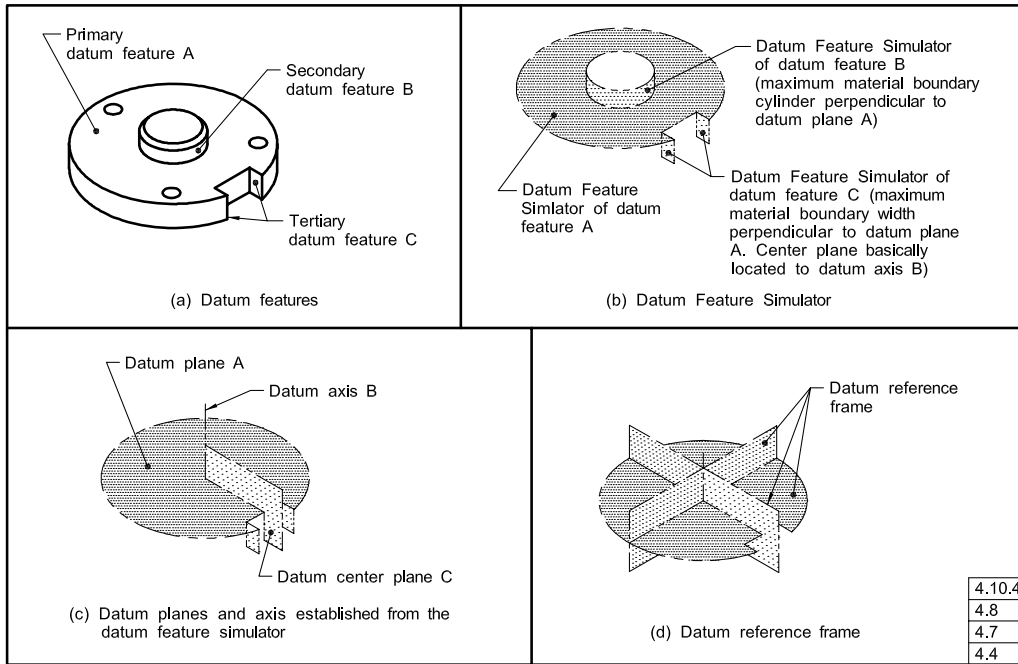


Fig. 4-5 Part Where Rotational Constraint Is Important



**Fig. 4-6 Development of a Datum Reference Frame for Part in Fig. 4-5**



**Fig. 4-7 Inclined Datum Features**

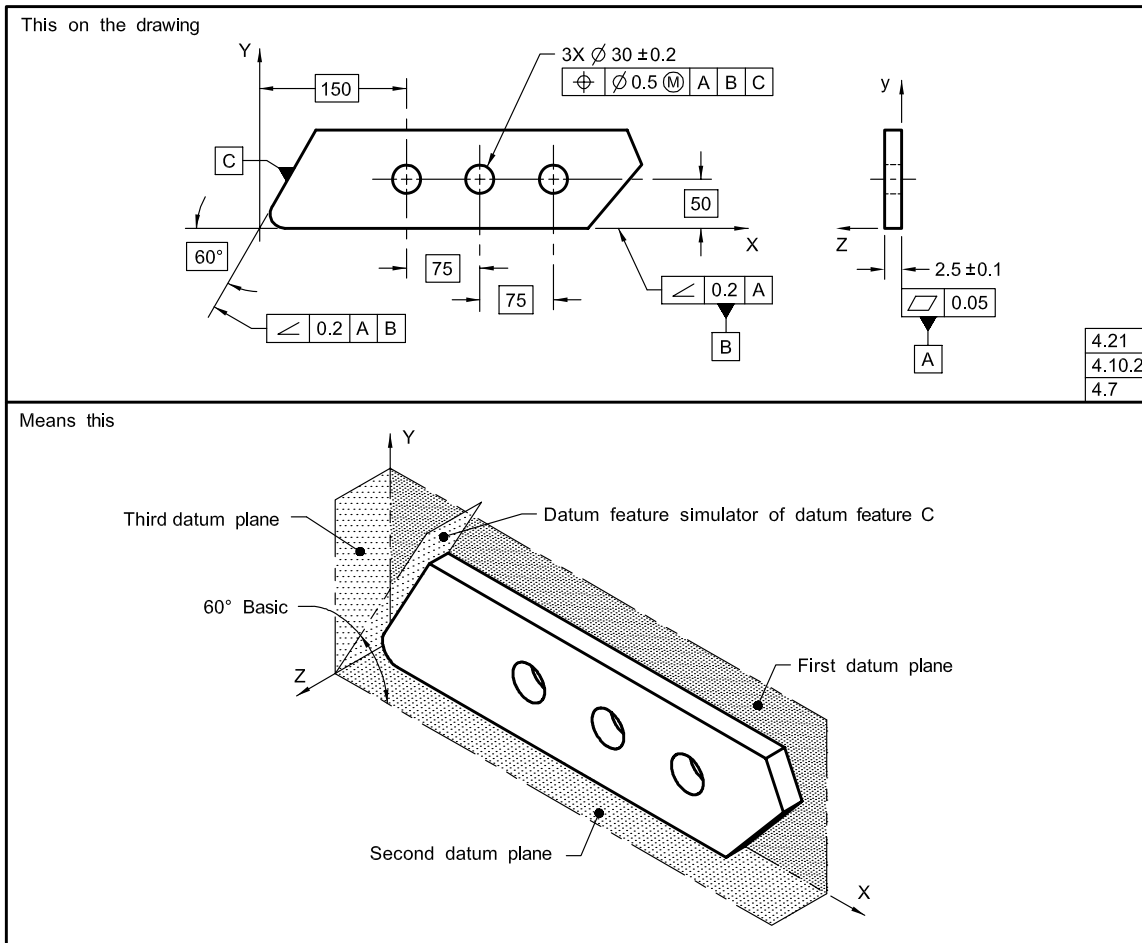
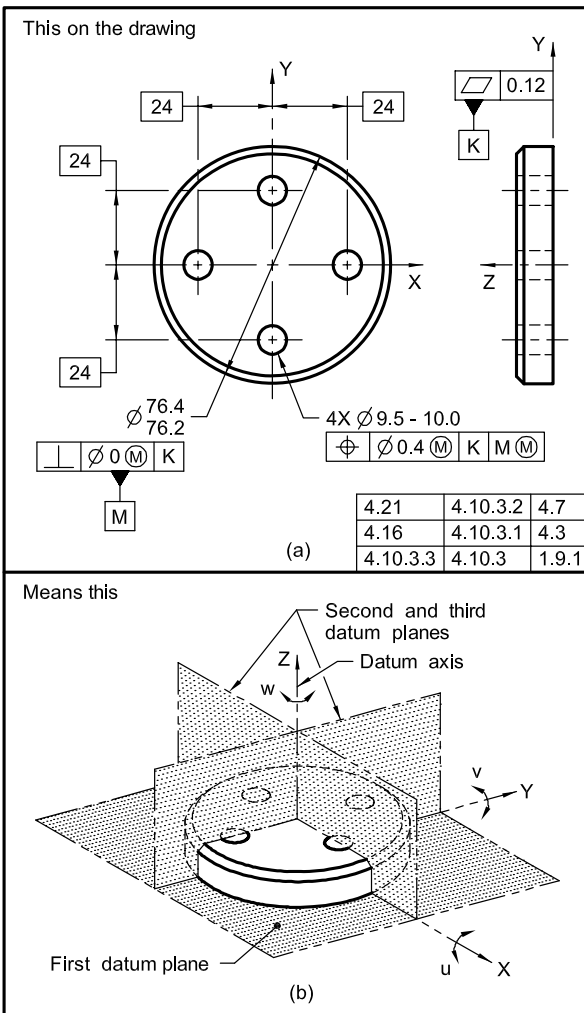




Fig. 4-8 Part With Cylindrical Datum Feature



NOTE: The sequence of establishing a datum reference frame from datum features and datum feature simulators is described in the preceding paragraph. In subsequent text, for brevity, this process will be described as establishing a datum reference frame from datum features.

## 4.5 DATUM FEATURE SIMULATOR

A datum feature simulator, as defined in para. 1.3.17, shall be the inverse shape of the datum feature, unless otherwise specified. See Figs. 4-10, 4-11, 4-12, 4-13, and 4-14.

### 4.5.1 Examples

A datum feature simulator may be one of the following:

- a maximum material boundary (MMB)
- a least material boundary (LMB)
- an actual mating envelope
- a minimum material envelope
- a tangent plane
- a datum target(s)
- a mathematically defined contour

### 4.5.2 Requirements

Datum feature simulators shall have the following requirements:

- perfect form.
- basic orientation relative to one another for all the datum references in a feature control frame.
- basic location relative to other datum feature simulators for all the datum references in a feature control frame, unless a translation modifier or movable datum target symbol is specified. See Figs. 4-9, 4-19, and 4-32, illustration (a).
- movable location when the translation modifier or the movable datum target symbol is specified. See Figs. 4-19, 4-32, illustration (b), and 4-49.
- fixed at the designated size, when MMB or LMB is specified.
- adjustable in size, when the datum feature applies at RMB.

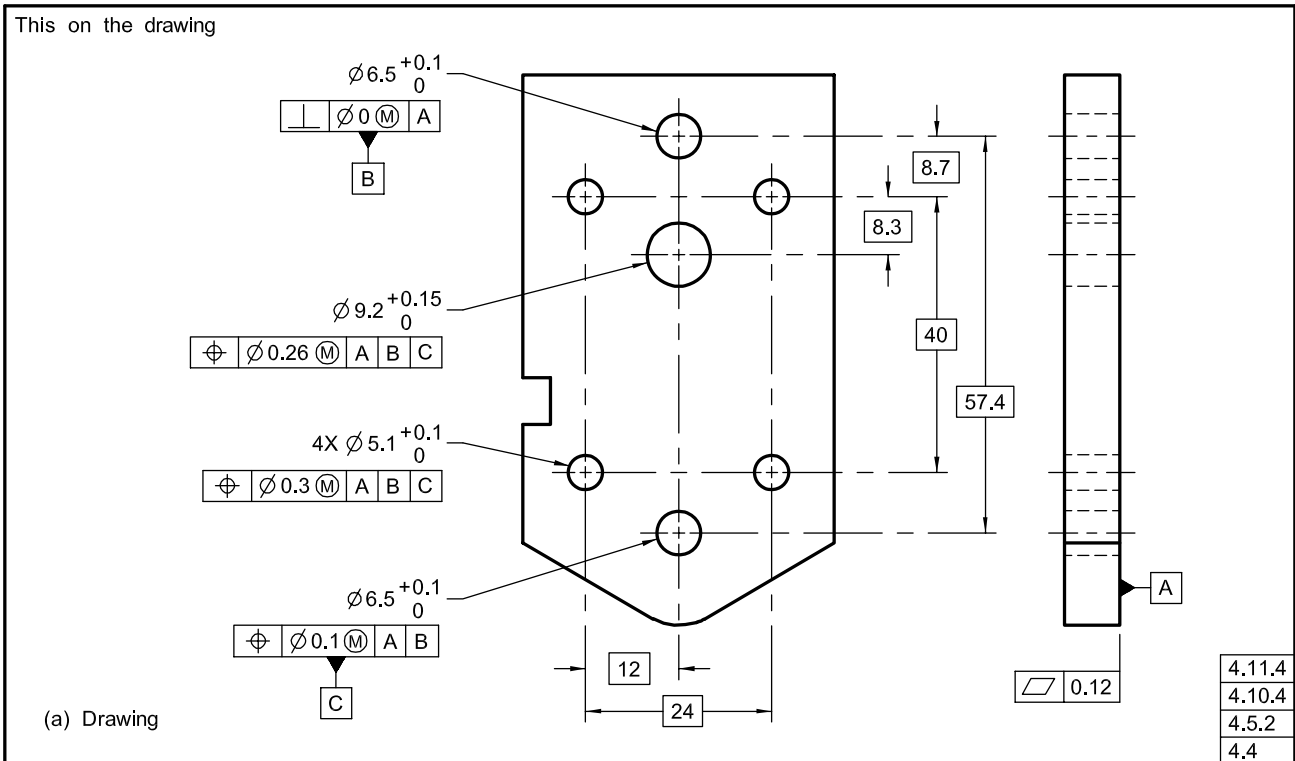
## 4.6 THEORETICAL AND PHYSICAL APPLICATION OF DATUM FEATURE SIMULATORS

This Standard defines engineering specifications relative to theoretical datums established from theoretical datum feature simulators. In the practical application, measurements cannot be made from datums or datum feature simulators which are theoretical, therefore simulated datums are established using physical datum feature simulators. For example, machine tables and surface plates, though not true planes, are of such quality that the planes derived from them are used to establish the simulated datums from which measurements are taken and dimensions verified. See Fig. 4-10. Also, for example, ring and plug gages, and mandrels, though not true cylinders, are of such quality that their axes are used as simulated datums from which measurements are taken and dimensions verified. See Figs. 4-11 and 4-12. When magnified surfaces of manufactured parts are seen to have irregularities, contact is made with a datum feature simulator at a number of surface extremities or high points. The principles in this Standard are based on theoretical datum feature simulators and do not take into account any tolerances or error in the physical datum feature simulators. See ASME Y14.43.

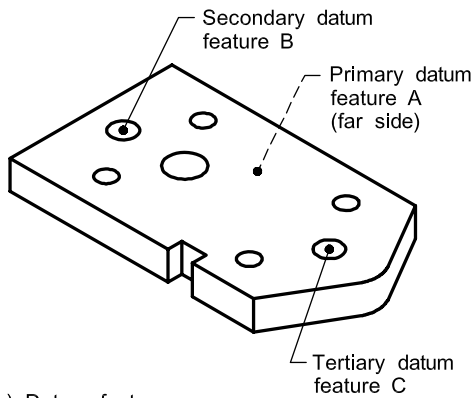
## 4.7 DATUM REFERENCE FRAME

Sufficient datum features or designated portions of these features are chosen to position the part in relation to a set of three mutually perpendicular planes, jointly called a datum reference frame. This reference frame exists in theory only and not on the part. See Fig. 4-1. Therefore, it is necessary to establish a method of simulating the theoretical reference frame from the actual features of the part. In practice, the features are associated with physical or mathematical elements

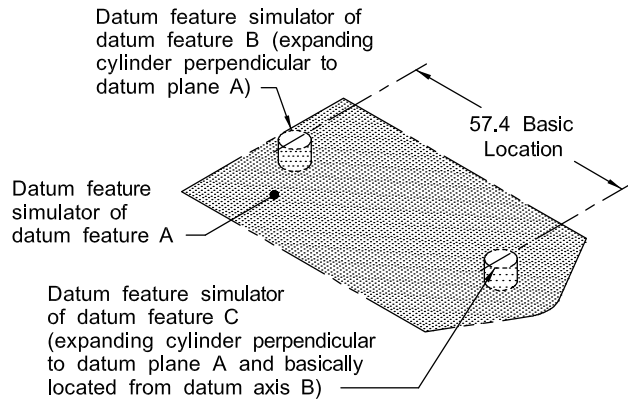
Fig. 4-9 Development of a Datum Reference Frame



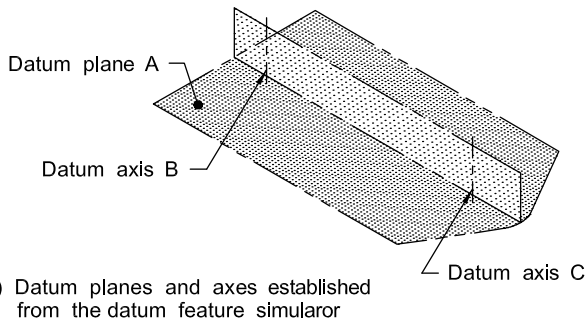
Means this



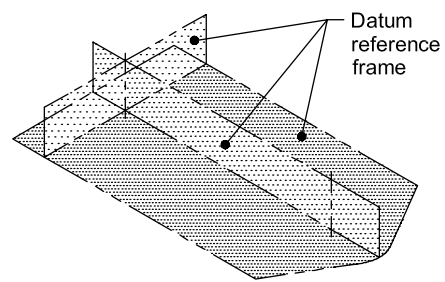
(b) Datum features



(c) Datum feature simulators

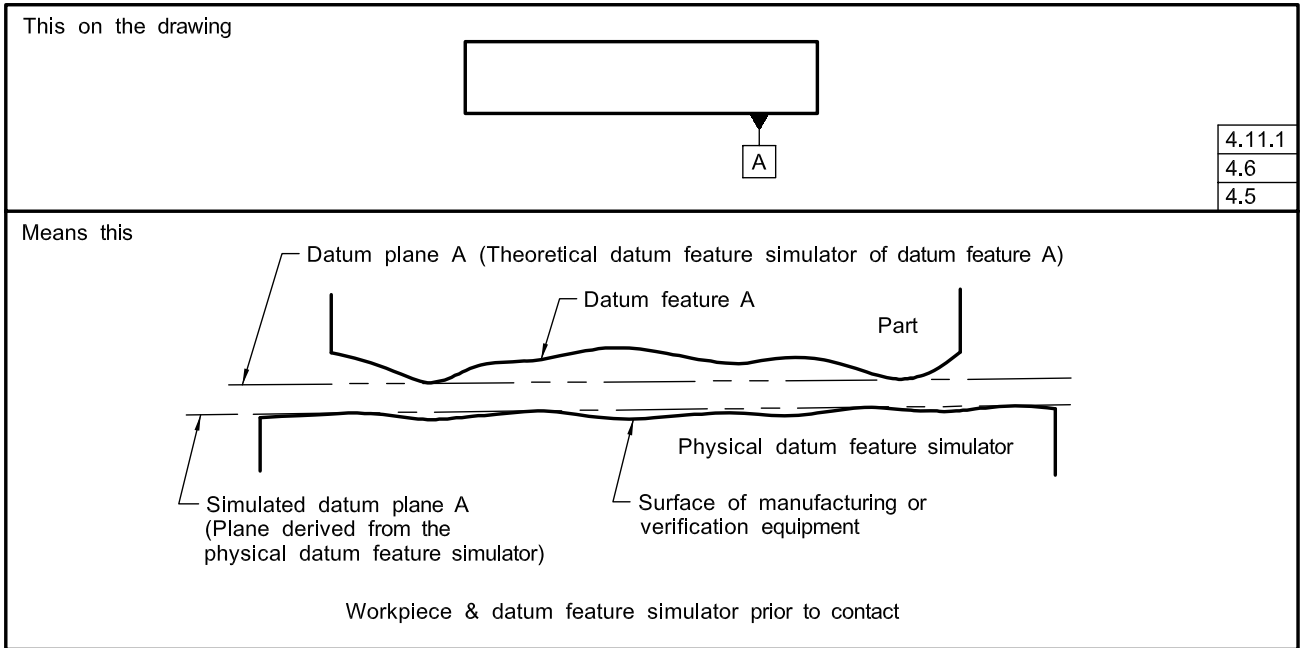


(d) Datum planes and axes established from the datum feature simulator

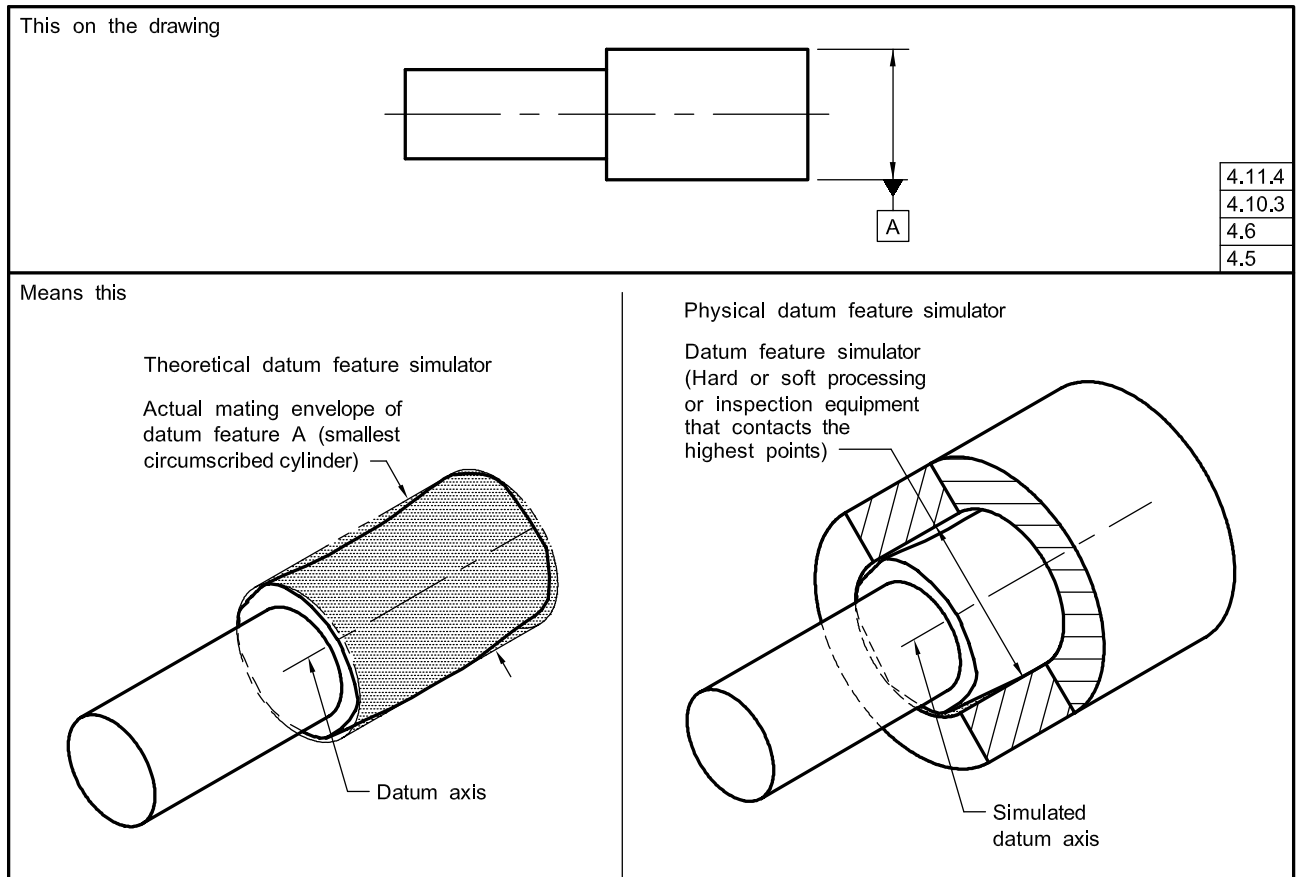


(e) Datum reference frame

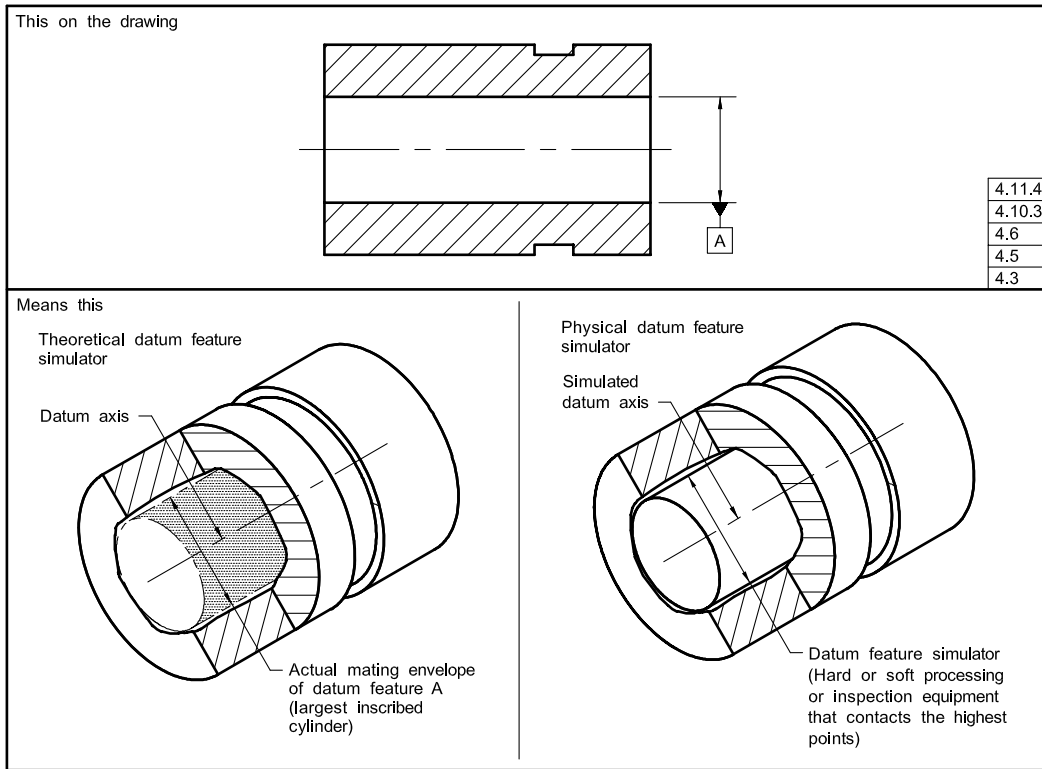
**Fig. 4-10 Datum Plane Establishment**



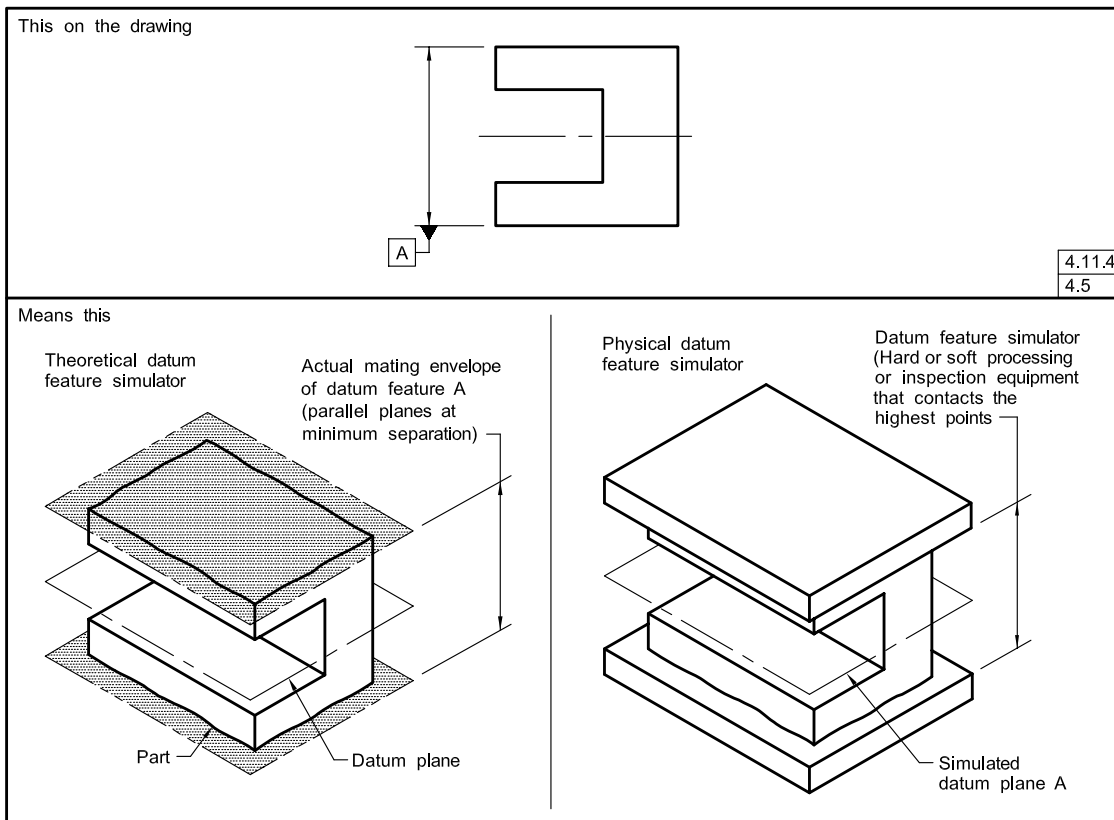
**Fig. 4-11 Establishment of Datums – For External Cylindrical Feature – RMB**

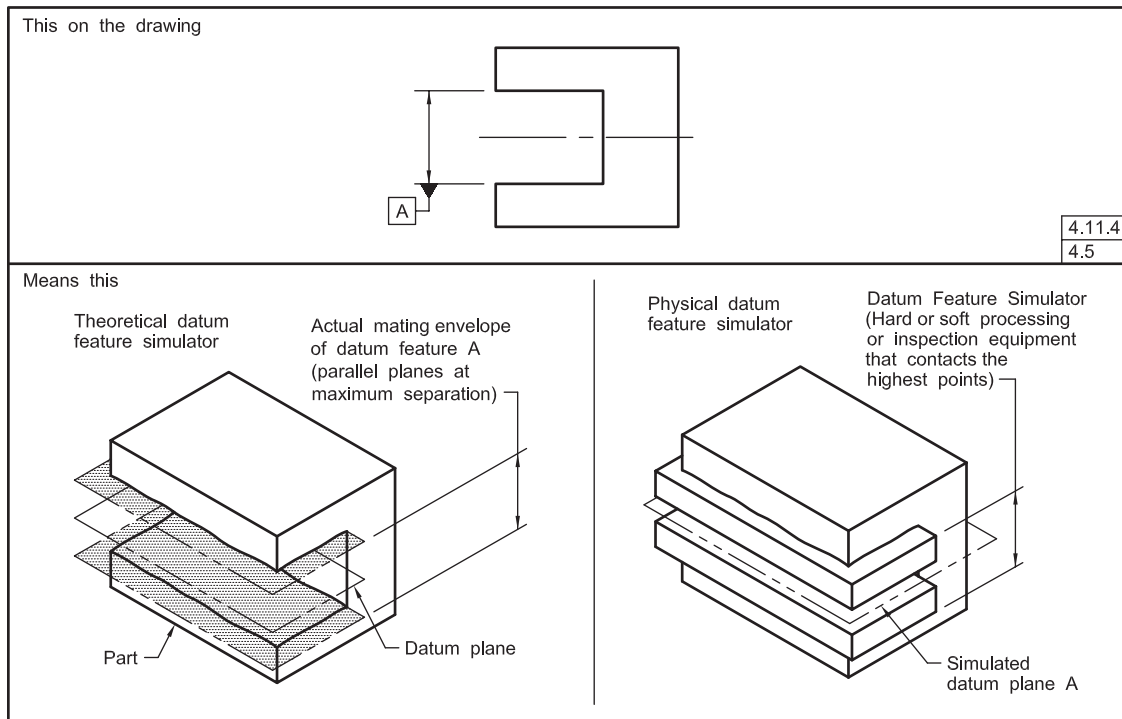


**Fig. 4-12 Establishment of Datums — For Internal Cylindrical Feature — RMB**



**Fig. 4-13 Establishment of Datums — For External Datum Width — RMB**



**Fig. 4-14 Establishment of Datums — For Internal Datum Width — RMB**

that simulate the datum feature simulators in a stated order of precedence and according to applicable modifiers. This constrains the applicable degrees of freedom between the part and the associated datum reference frame. See Figs. 4-2, 4-5, 4-6, 4-7, and 4-8.

#### 4.7.1 Mutually Perpendicular Planes

The planes of the datum reference frame are simulated in a mutually perpendicular relationship to provide direction as well as the origin for related dimensions. Thus, when the part is positioned relative to the datum reference frame (by contact between each datum feature and its counterpart in the associated processing equipment), dimensions related to the datum reference frame by a feature control frame or note are basically related. This theoretical reference frame constitutes the three-plane dimensioning system used for dimensioning and tolerancing.

#### 4.7.2 Number of Datum Reference Frames

In some cases, a single datum reference frame will suffice. In others, additional datum reference frames may be necessary where physical separation or the functional relationship of features requires that different datum reference frames be applied. In such cases, each feature control frame must contain the datum feature references that are applicable. Any difference in the order of precedence or in the material boundary of any datum features referenced in multiple feature control frames requires different datum simulation methods and, consequently, establishes a different datum reference frame. See Fig. 4-4.

## 4.8 DATUM FEATURES

A datum feature is selected on the basis of its functional relationship to the toleranced feature and the requirements of the design. See Figs. 4-5, 4-6, 4-36, 4-37, and 4-38. To ensure proper assembly, corresponding interfacing features of mating parts should be selected as datum features. However, a datum feature should be accessible on the part and of sufficient size to permit its use. Datum features must be readily discernible on the part. Therefore, in the case of symmetrical parts or parts with identical features, physical identification of the datum feature on the part may be necessary.

#### 4.8.1 Temporary and Permanent Datum Features

Features of in-process parts, such as castings, forgings, machinings, or fabrications, may be used as temporary datum features to create permanent datum features. Such temporary datum features may or may not be subsequently removed by machining. Permanent datum features should be surfaces or diameters not appreciably changed by subsequent processing operations.

#### 4.8.2 Datum Feature Identification

Datum features are identified on the drawing by means of a datum feature symbol. See Figs. 3-2, 3-3, and 3-4. The datum feature symbol identifies physical features and shall not be applied to center lines, center planes, or axes.

## 4.9 DATUM FEATURE CONTROLS

Geometric tolerances related to a datum reference frame do not take into account any variations in form, orientation, or location of the datum features. Datum features shall be controlled directly by applying appropriate geometric tolerances or indirectly by dimensions such as the size of a primary datum feature of size. This in turn makes it possible to calculate the datum feature simulator boundaries of each datum feature in a datum reference frame. The relationships between datum features to be considered are the

(a) form of the primary datum feature(s) (see Figs. 4-2 and 4-5) and/or the location between features in a pattern used to establish the primary datum. See Figs. 4-24 and 4-25.

(b) secondary datum features' orientation and/or location as applicable, to higher precedence datums. See Figs. 4-2, 4-5, 4-26, and 4-30.

(c) tertiary datum features' orientation and/or location to higher precedence datums as applicable. See Figs. 4-2 and 4-5.

### 4.10 SPECIFYING DATUM FEATURES IN AN ORDER OF PRECEDENCE

Datum features must be specified in an order of precedence to position a part properly relative to the datum reference frame. Figure 4-2 illustrates a part where the datum features are planar surfaces. The desired order of precedence is indicated by entering the appropriate datum feature reference letters, from left to right, in the feature control frame.

#### 4.10.1 Development of a Datum Reference Frame for Parts With Planar Surface Datum Features

The feature control frame in Fig. 4-2 illustrates the datum reference frame for the part shown in its functional assembly in Fig. 4-2, illustration (b). Figure 4-2 illustrates the development of the datum reference frame along with degrees of freedom. The datum features referenced in the feature control frame immobilize the part and constrain the six degrees of freedom (three translations and three rotations) to establish a datum reference frame. Relating a part to a datum feature simulator and a datum reference frame in this manner ensures consistent understanding of engineering requirements. See Fig. 4-1.

(a) In Fig. 4-2, illustration (a), datum feature D is specified as the primary datum feature. Where a surface is specified as a datum feature, the high point(s) on the surface establish a datum plane. This primary datum feature contacts the datum feature simulator on a minimum of three points (see para. 4.11.2 for discussion on rocking or unstable datum features). In this example, where the primary datum feature contacts the datum

feature simulator, three degrees of freedom (one translation and two rotations) are constrained: rotation about the X-axis (u), rotation about the Y-axis (v), and translation in the Z direction.

(b) Datum feature E is specified as the secondary datum feature. This feature contacts the datum feature simulator at a minimum of two points. See Fig. 4-2, illustration (d). In this example, where the secondary datum feature contacts its datum feature simulator, two degrees of freedom (one translation and one rotation) are constrained: translation in the X direction and rotation about the Z-axis (w).

(c) Datum feature F is specified as the tertiary datum feature. See Fig. 4-2, illustration (e). In this example, where the tertiary datum feature contacts its datum feature simulator at a minimum of one point, the remaining degree of freedom is constrained: translation in the Y direction.

#### 4.10.2 Parts With Inclined Datum Features

For parts with inclined datum features as shown in Fig. 4-7, a datum feature simulator plane is oriented at the basic angle of the datum feature. The corresponding plane of the datum reference frame passes through the vertex of the basic angle and is mutually perpendicular to the other two planes.

#### 4.10.3 Parts With Cylindrical Datum Features

The datum of a cylindrical datum feature is the axis of the datum feature simulator. This axis serves as the origin for relationships defined by geometric tolerances. See Figs. 4-8, 4-11, and 4-12. A primary cylindrical datum feature is always associated with two theoretical planes intersecting at right angles on the datum axis. Depending on the number of planes established by higher precedence datums, secondary and tertiary datum axes may establish zero, one, or two theoretical planes.

**4.10.3.1 Cylindrical Datum Feature.** Figure 4-8 illustrates a part having a cylindrical datum feature. Primary datum feature K relates the part to the first datum plane. Since secondary datum feature M is cylindrical, it is associated with two theoretical planes, the second and third in a three-plane relationship.

**4.10.3.2 Datum Axis and Two Planes.** The two theoretical planes are represented on a drawing by center lines crossing at right angles, as in Fig. 4-8, illustration (a). The intersection of these planes coincides with the datum axis. See Fig. 4-8, illustration (b). Once established, the datum axis becomes the origin for related dimensions.

**4.10.3.3 Orientation of Two Planes.** The orientation of the second and third planes of the datum reference frame in Fig. 4-8 is not specified, as rotation of the

pattern of holes about the datum axis has no effect on the function of the part. In such cases, only two datum features are referenced in the feature control frame:

(a) primary datum feature K, which establishes a datum plane

(b) secondary datum feature M, which establishes a datum axis perpendicular to datum plane K

#### 4.10.4 Constraining Rotational Degrees of Freedom.

To constrain the rotational degree of freedom of two planes about a datum axis, a lower precedence datum feature is referenced in the feature control frame. See para. 4.16.

(a) Figure 4-5 illustrates the constraint of the rotational degree of freedom of the two planes intersecting through the secondary datum feature B, established by the center plane of the tertiary datum feature C. Figure 4-6 illustrates the development of the datum reference frame for the positional tolerance of the three holes in Fig. 4-5.

(b) Figure 4-9 illustrates the constraint of the rotational degree of freedom of the two planes intersecting through the secondary datum feature B. Constraint is established by the tertiary datum feature C.

(c) Figures 4-29 through 4-31 illustrate the constraint of the rotational degree of freedom of the two planes intersecting through datum feature A. Constraint is established by datum feature B.

### 4.11 ESTABLISHING DATUMS

The following paragraphs define the criteria for establishing datums from datum features.

#### 4.11.1 Plane Surfaces as Datum Features

Where a nominally flat surface is specified as a datum feature, the corresponding datum feature simulator is a plane contacting points of that surface. See Fig. 4-10. The number of points contacted by the datum feature simulator depends on whether the surface is a primary, a secondary, or a tertiary datum feature. See para. 4.10.1.

#### 4.11.2 Irregularities on Datum Features

If irregularities on a datum feature are such that the part is unstable (that is, it rocks) when brought into contact with the corresponding datum feature simulator, the default stabilization procedure is per the candidate datum set as outlined in ASME Y14.5.1M. If a different procedure is desired (Chebychev, least squares, translational least squares, etc.), it must be specified.

#### 4.11.3 Effect of Material Boundary Modifiers Applied to Datum Feature References

MMB, LMB, and RMB conditions may be applied/implied to any datum feature reference in a feature

control frame. Modifiers applicable to datum features referenced in a feature control frame will affect the relationship of the part to the datum reference frame. See Figs. 4-20 and 4-21.

#### 4.11.4 Specifying Datum Features RMB

Where a datum feature is referenced at RMB in a feature control frame, the datum feature simulator geometry originates at the MMB and progresses proportionally through the tolerance zone to make maximum possible contact with the extremities of the datum feature or collection of features. If another fitting routine is required, it shall be stated on the drawing. As a practical example, a machine element that is variable (such as a chuck, mandrel, vise, or centering device) is used to simulate a datum feature simulator of the feature and to establish the simulated datum.

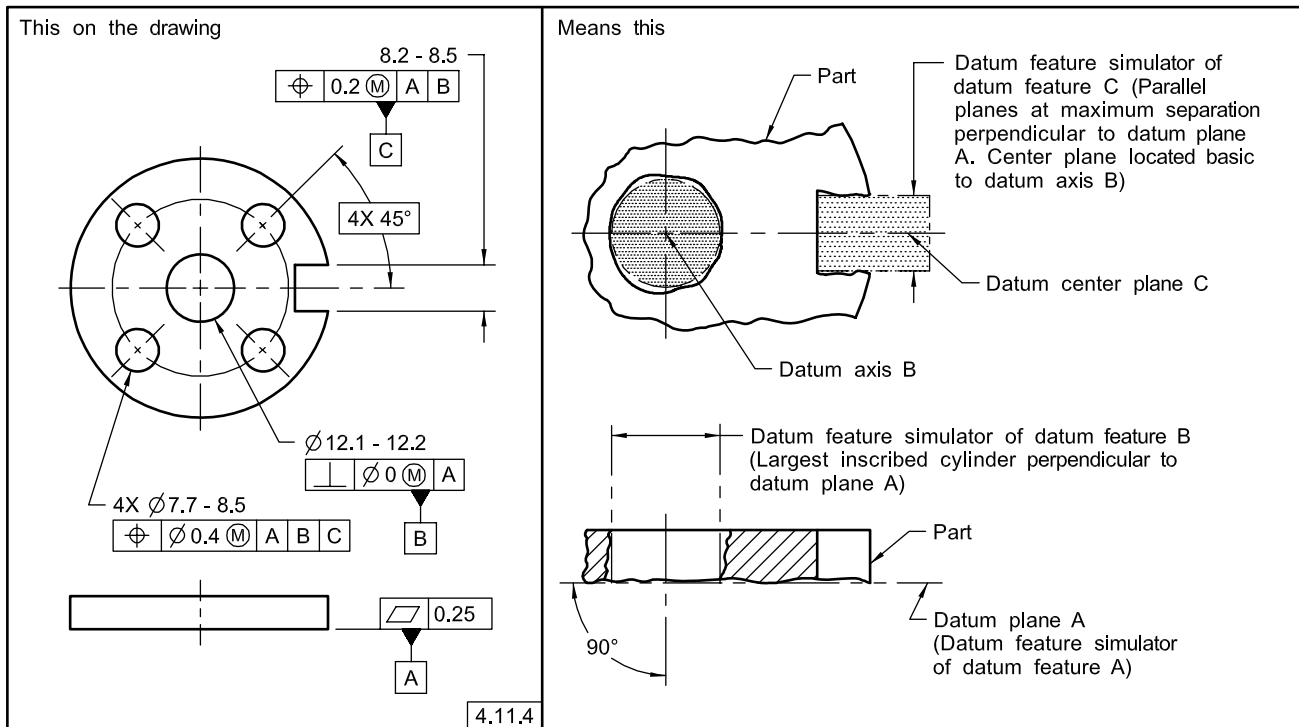
(a) *Primary Datum Feature: Diameter RMB.* The datum is the axis of the datum feature simulator of the datum feature. The datum feature simulator (or unrelated actual mating envelope) is the smallest circumscribed (for an external feature) or largest inscribed (for an internal feature) perfect cylinder that makes maximum possible contact with the datum feature surface. See Figs. 4-3, illustration (d); 4-11; and 4-12.

(b) *Primary Datum Feature: Width RMB.* The datum is the center plane of the datum feature simulator of the datum feature. The datum feature simulator (or unrelated actual mating envelope) is two parallel planes at minimum separation (for an external feature) or maximum separation (for an internal feature) that makes maximum possible contact with the corresponding surfaces of the datum feature. See Figs. 4-3, illustration (b); 4-13; and 4-14.

(c) *Primary Datum Feature: Sphere RMB.* The datum is the center point of the datum feature simulator of the datum feature. The datum feature simulator (or unrelated actual mating envelope) is the smallest circumscribed (for an external feature) or largest inscribed (for an internal feature) perfect sphere that make maximum possible contact with the datum feature surface. See Fig. 4-3, illustration (c).

(d) *Secondary Datum Feature RMB: Diameter or Width.* For both external and internal features, the secondary datum (axis or center plane) is established in the same manner as indicated in subparas. (a) and (b) above with an additional requirement. The theoretical cylinder or parallel planes of the datum feature simulator must be oriented and/or located to the primary datum feature's datum feature simulator. Datum feature B in Fig. 4-15 illustrates this principle for diameters, and Fig. 4-32, illustration (a), illustrates the same principle for widths. In Fig. 4-32, illustration (a), the secondary datum feature simulator at RMB expands and makes maximum possible contact constraining all possible remaining degrees of freedom, before the tertiary datum feature simulator is allowed to expand.

Fig. 4-15 Secondary and Tertiary Datum Features — RMB



(e) *Tertiary Datum Feature: Diameter or Width RMB.* For both external and internal features, the tertiary datum (axis or center plane) is established in the same manner as indicated in subpara. (d) above with an additional requirement: the theoretical cylinder or parallel planes of the datum feature simulator must be oriented and/or located to both the primary and secondary datum features' datum feature simulators. The tertiary datum feature may be located to the datum axis as in Fig. 4-15 or offset from a plane of the datum reference frame. Figure 4-9 illustrates the same principle for a diameter.

(f) *Secondary and Tertiary Datum Feature: Sphere RMB.* The secondary or tertiary datum (center point) is established in the same manner as indicated in subpara. (c) above, except that the center point is located relative to higher precedence datums.

(g) *Secondary and Tertiary Surface RMB.* Where the datum feature (secondary or tertiary) is a surface, RMB applied to the datum feature requires the datum feature simulator to expand, contract, or progress normal to the true profile of the feature from its MMB to its LMB until the datum feature simulator makes maximum possible contact with the extremities of the datum feature while respecting the higher precedence datum(s). See Figs. 4-29, illustration (a); 4-30, illustration (a); and 4-31, illustration (a).

#### 4.11.5 Specifying Datum Features at MMB

Where MMB is applied to a datum feature referenced in a feature control frame it establishes the datum feature simulator of the appropriate boundary. The appropriate

boundary is determined by its collective effects of size, and any applicable geometric tolerances relative to any higher precedence datums. As a practical example, where a datum feature is applied on an MMB basis, machine and gaging elements in the processing equipment that remain constant may be used to simulate a datum feature simulator of the feature and to establish the simulated datum. To determine the applicable boundary, see para 4.11.6.

#### 4.11.6 Determining Size of Datum Feature Simulators at MMB

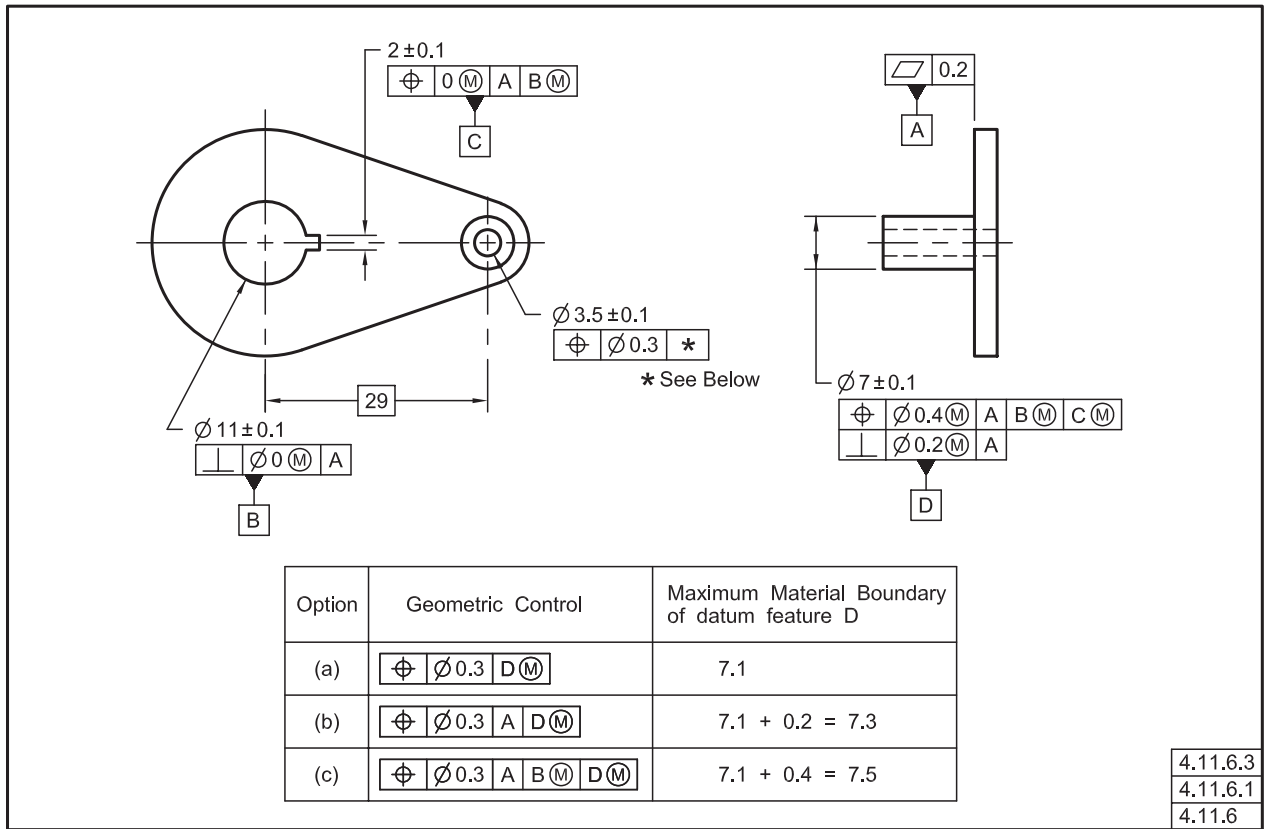
An analysis of geometric tolerances applied to a datum feature is necessary in determining the size of its datum feature simulator. A feature of size or pattern of features of size serving as a datum feature may have several MMB. These include the MMC of a datum feature of size or the collective effects of MMC and geometric tolerances. Datum feature precedence shall be respected, except in the case of a customized datum reference frame. See para. 4.22. Therefore, the appropriate MMB for determining the size of the datum feature simulator for an

(a) internal datum feature of size is the largest MMB that the datum feature(s) of size will contain while respecting the datum feature precedence.

(b) external feature of size is the smallest MMB that will contain the datum feature(s) of size while respecting the datum feature precedence. See Fig. 4-16 for examples of calculating the size of MMB.



Fig. 4-16 Example Calculations of Maximum Material Boundary



**4.11.6.1 Determining the Correct Maximum Material Boundary (MMB).** Datum feature D in Fig. 4-16 has three MMB. For an external feature of size the appropriate MMB is the smallest value that will contain the datum feature of size while respecting datum feature precedence.

(a) In option (a) where datum feature D is referenced as primary, the appropriate MMB is the MMC of the feature or 7.1 mm (Rule #1).

(b) In option (b), where datum feature D is referenced as secondary to ensure that datum precedence is not violated, the collective effects of the MMC (7.1 mm diameter) and the perpendicularity tolerance (0.2 mm diameter) establishes an MMB of 7.3 mm diameter.

(c) In option (c), where datum feature D is referenced as tertiary to ensure that datum precedence is not violated, the collective effects of the MMC (7.1 mm diameter) and the position tolerance (0.4 mm diameter) establishes an MMB of 7.5 mm diameter. Since the perpendicularity tolerance is a refinement of the position tolerance, it is not additive.

**4.11.6.2 Calculations for the MMB.** For the position tolerance applied to datum feature D, the appropriate

MMB for datum features B and C are 10.9 mm diameter (10.9 minus 0 perpendicularity tolerance) and 1.9 mm (1.9 MMC minus 0 position tolerance), respectively.

**4.11.6.3 Clarifying Applicable MMB.** In cases where the boundary is not clear, or another boundary is desired, the value of the boundary shall be stated, enclosed in brackets, following the applicable datum feature reference and any modifier in the feature control frame. The term "BSC" or "BASIC" may be used to indicate that the datum feature simulator is located at the basic location of the datum feature. See Fig. 4-31, illustration (b).

**EXAMPLE:**

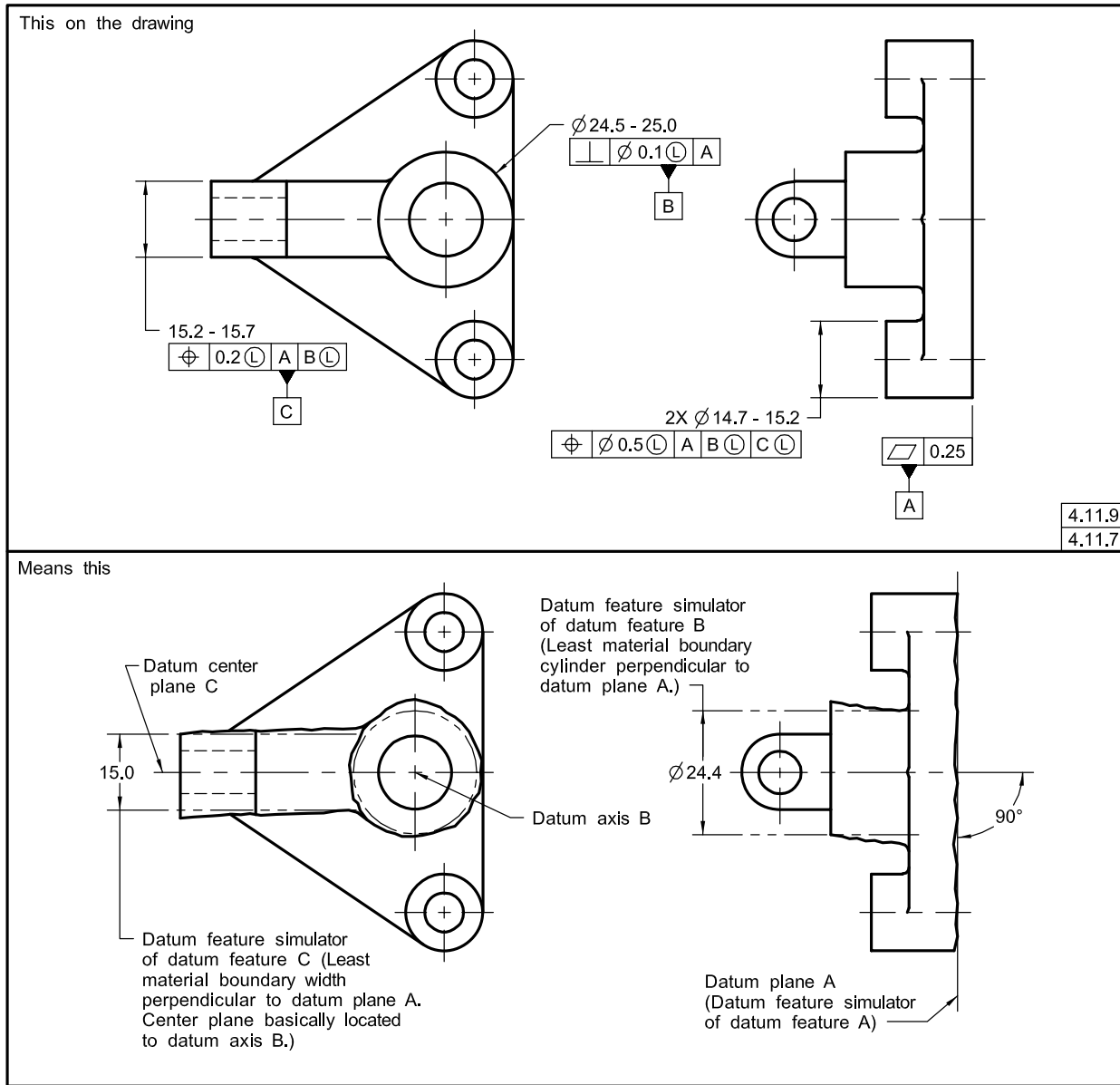
$$\text{⌀} \text{⌀}0.3 \text{ A} \text{ B} \text{ D} \text{ (M)} [\text{⌀}7.5]$$

OR

$$\text{⌀} \text{⌀}0.3 \text{ A} \text{ B} \text{ D} [\text{BASIC}]$$

Where an MMB equal to MMC is the design requirement for a given datum feature, a zero geometric tolerance at MMC is specified to the datum feature as shown on datum features B and C in Fig. 4-16. See para. 7.3.4 and Fig. 6-14.

Fig. 4-17 Secondary and Tertiary Datum Features at LMB



4.11.9  
4.11.7

**4.11.7 Specifying Datum Features at LMB**

Where LMB is applied to a datum feature referenced in a feature control frame it establishes the datum feature simulator at the appropriate boundary. The appropriate boundary is determined by its collective effects of size, and any applicable geometric tolerances relative to any higher precedence datums. See para. 2.11 and Fig. 4-17. This example illustrates both secondary and tertiary datum features specified at LMB and simulated at LMB.

**4.11.8 Multiple LMBs**

A feature or pattern of features serving as a datum feature may have several LMB. These include the

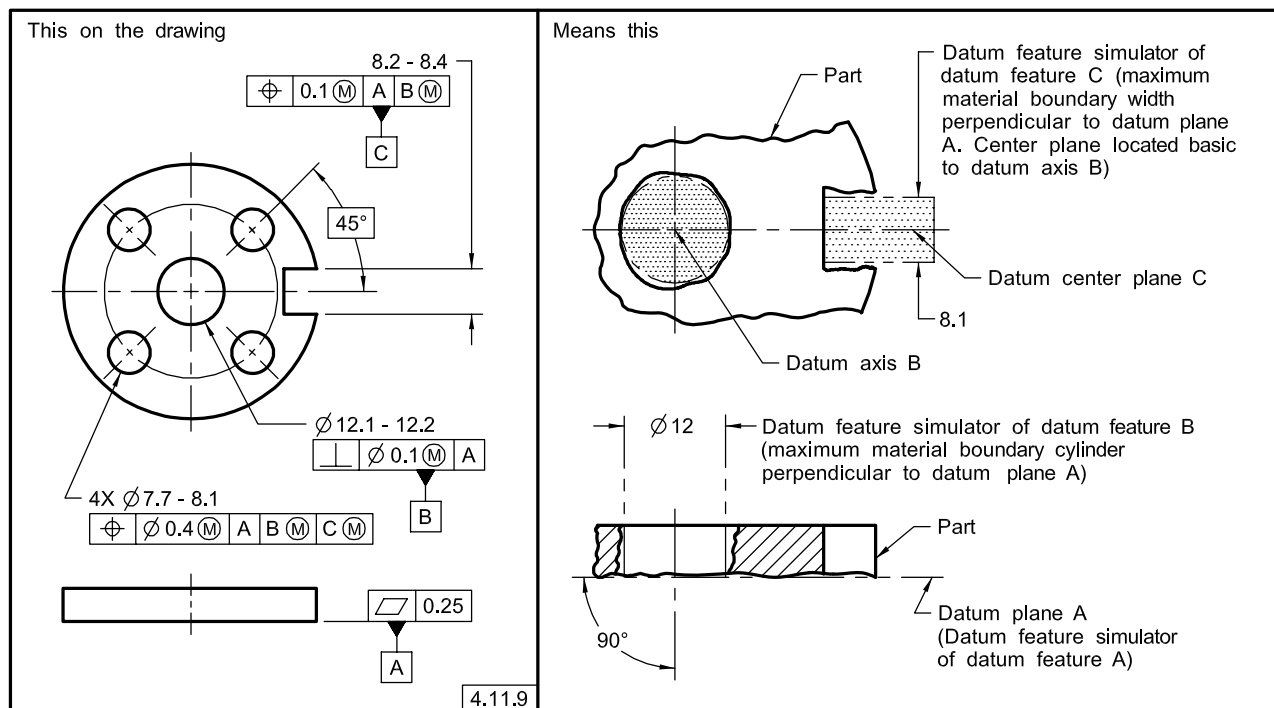
LMC of a feature or the collective effects of LMC and geometric tolerances. Datum precedence may not be violated, except in the case of a customized datum reference frame. In cases where the boundary is not clear, or another boundary is desired, the value of the boundary shall be stated following the applicable datum feature reference any modifier in the feature control frame.

**EXAMPLE:**



The appropriate LMB for (a) internal features is the smallest LMB that will contain the feature(s) while not violating datum precedence

Fig. 4-18 Secondary and Tertiary Datum Features at MMB



(b) external features is the largest LMB that the feature(s) will contain while not violating datum precedence

#### 4.11.9 Datum Feature Shift/Displacement

MMB or LMB modifiers applied to the datum feature reference will allow the datum feature to shift/displace from the boundary established by the datum feature simulator in an amount that is equal to the difference between the applicable (unrelated or related) actual mating envelope for MMB, actual minimum material envelope for LMB, or surface of the feature and the datum feature simulator. The datum reference frame is established from the datum feature simulator and not the datum features. See Fig. 4-17 for LMB, Figs. 4-18 and 4-24, datum feature B in Fig. 4-26 for MMB, and Fig. 4-30, illustration (b) for the surface. The datum feature shift/displacement shall always be limited or constrained by the datum feature simulator. If the datum feature simulator geometry is such that it does not fully limit or constrain the feature such as rotating away from the datum feature simulator beyond the established boundary limits, as shown in Fig. 4-31, illustration (c), then the feature must remain in contact with the datum feature simulator, and datum shift or displacement is not allowed. See para. 4.16.7 and datum feature A in Fig. 4-28.

#### 4.11.10 Translation Modifier

Where it is necessary to indicate that the basic location of the datum feature simulator is unlocked and the

datum feature simulator is able to translate within the specified geometric tolerance to fully engage the feature, the translation modifier is added to the feature control frame following the datum feature reference and any other applicable modifiers. See Figs. 4-19 and 4-32, illustration (b), and para. 3.3.26. When the translation modifier is applicable and the direction of movement is not clear, movement requirements shall be specified.

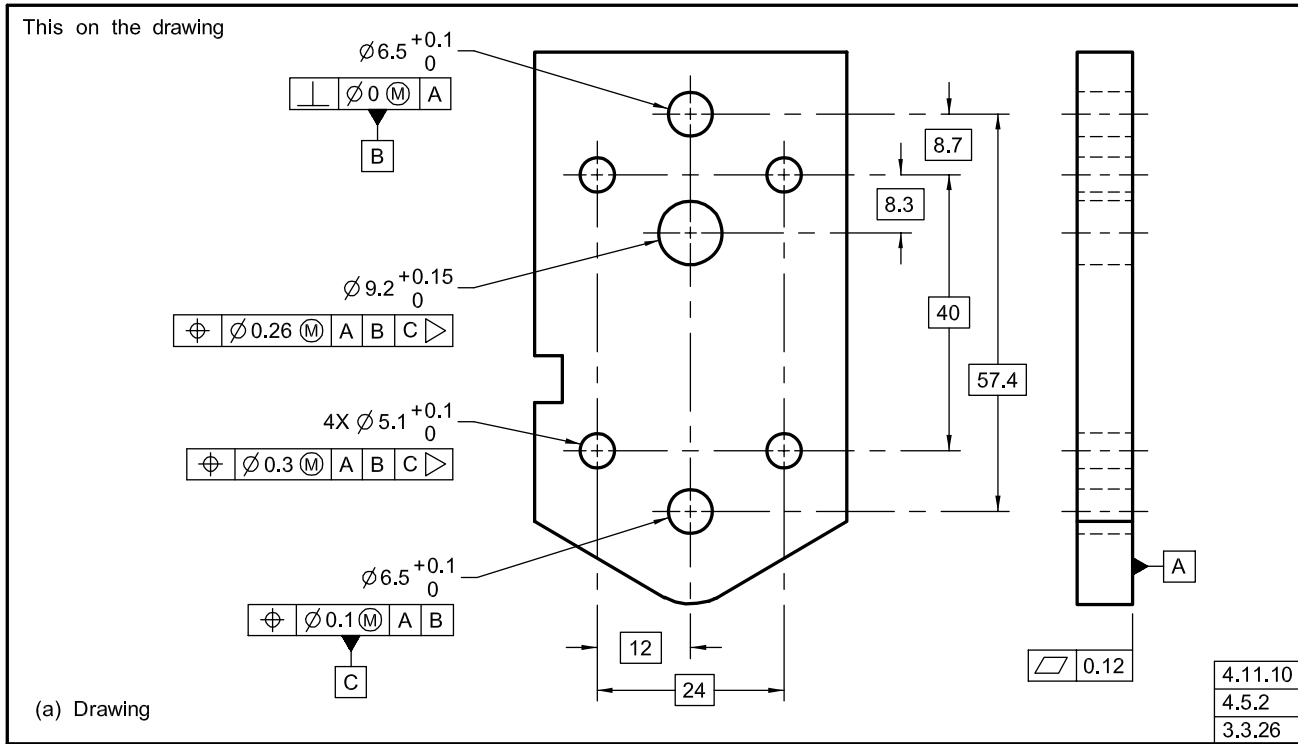
#### 4.11.11 Effects of Datum Precedence and Datum Feature Material Boundary Conditions

Where datums are specified in an order of precedence, the material boundary condition at which the datum feature applies must be determined. The effect of its material boundary condition and order of precedence should be considered relative to fit and function of the part. Figures 4-20 and 4-21 illustrate a part with a pattern of holes located in relation to diameter A and surface B. As indicated by asterisks, datum requirements may be specified in different ways.

#### 4.11.12 Cylindrical Feature at RMB Primary

In Fig. 4-21, illustration (b), diameter A is the primary datum feature and RMB is applied; surface B is the secondary datum feature. The datum axis is the axis of the datum feature simulator. The datum feature simulator is the smallest circumscribed cylinder that contacts diameter A that is, the unrelated actual mating envelope of diameter A. This cylinder encompasses variations in the size of A within specified limits. However, any variation

Fig. 4-19 Development of a Datum Reference Frame With Translation Modifier



Means this

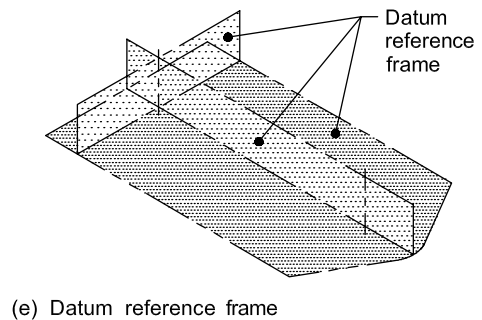
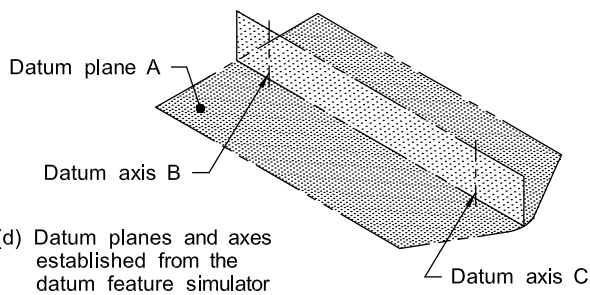
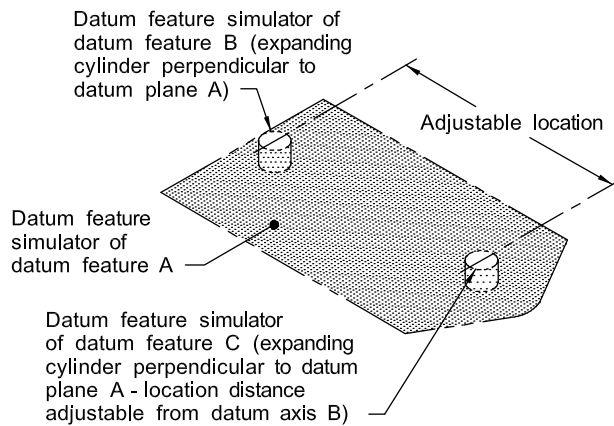
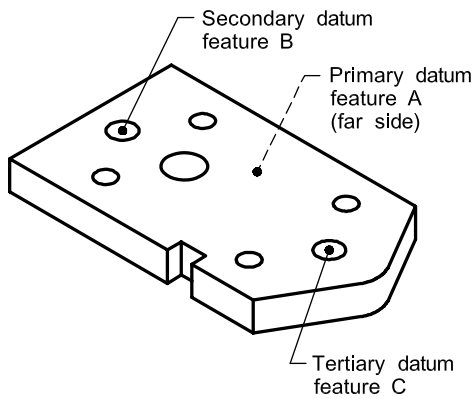
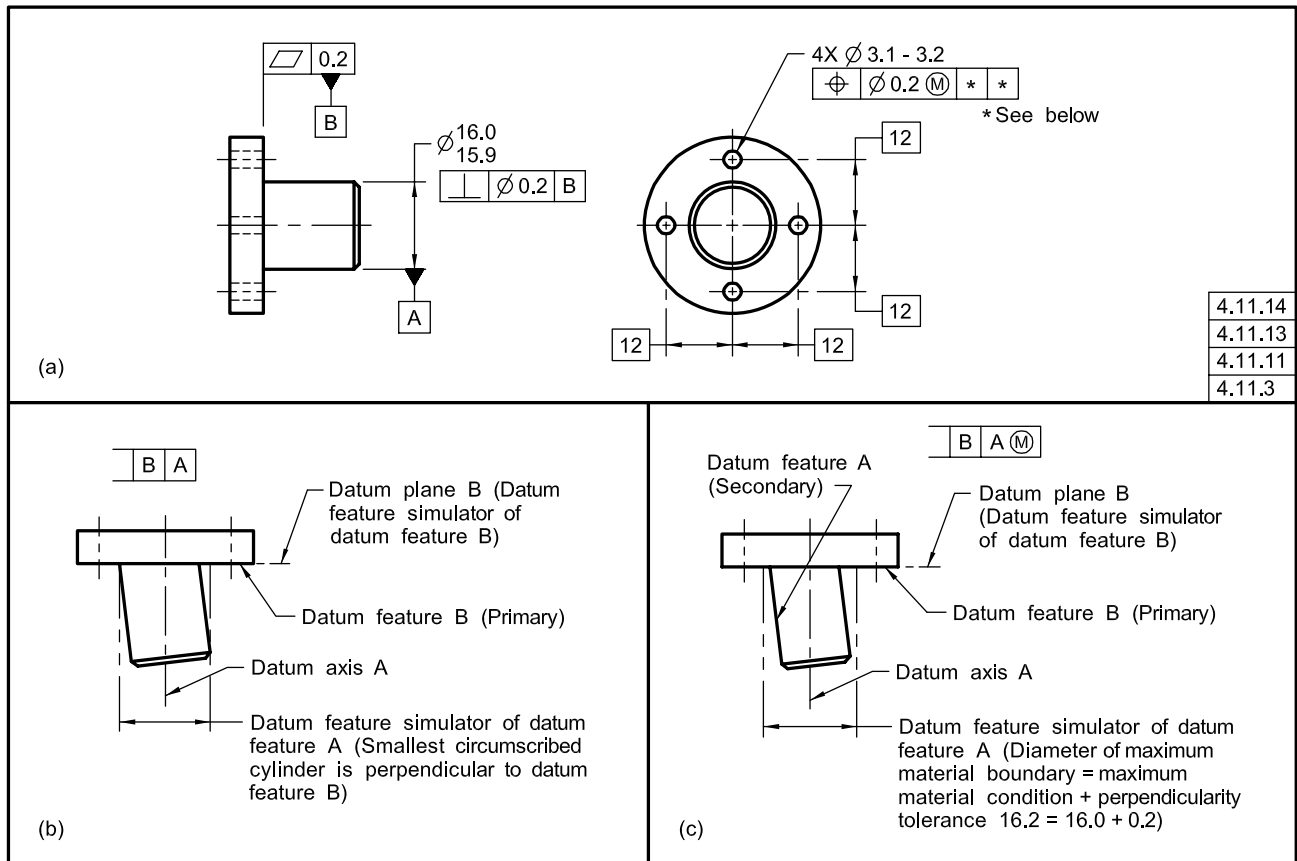


Fig. 4-20 Effect of Datum Modifier



in perpendicularity between surface B and diameter A, the primary datum feature, will affect the degree of contact of surface B with its datum feature simulator.

**4.11.13 Surface Primary**

In Fig. 4-20, illustration (b), surface B is the primary datum feature; diameter A is the secondary datum feature and RMB is applied. The datum axis is the axis of the smallest circumscribed cylinder that contacts diameter A and is perpendicular to the datum plane that is, the related actual mating envelope of the diameter that is perpendicular to datum plane B. In addition to size variations, this cylinder encompasses any variation in perpendicularity between diameter A and surface B, the primary datum feature.

**4.11.14 Cylindrical Feature at MMB Secondary**

In Fig. 4-20, illustration (c), surface B is the primary datum feature; diameter A is the secondary datum feature and MMB is applied. The datum axis is the axis of the datum feature simulator cylinder of fixed size that is perpendicular to the datum plane B. A displacement of the toleranced feature is allowed when there is clearance between the datum feature and the datum feature simulator. See para. 7.3.6.2.

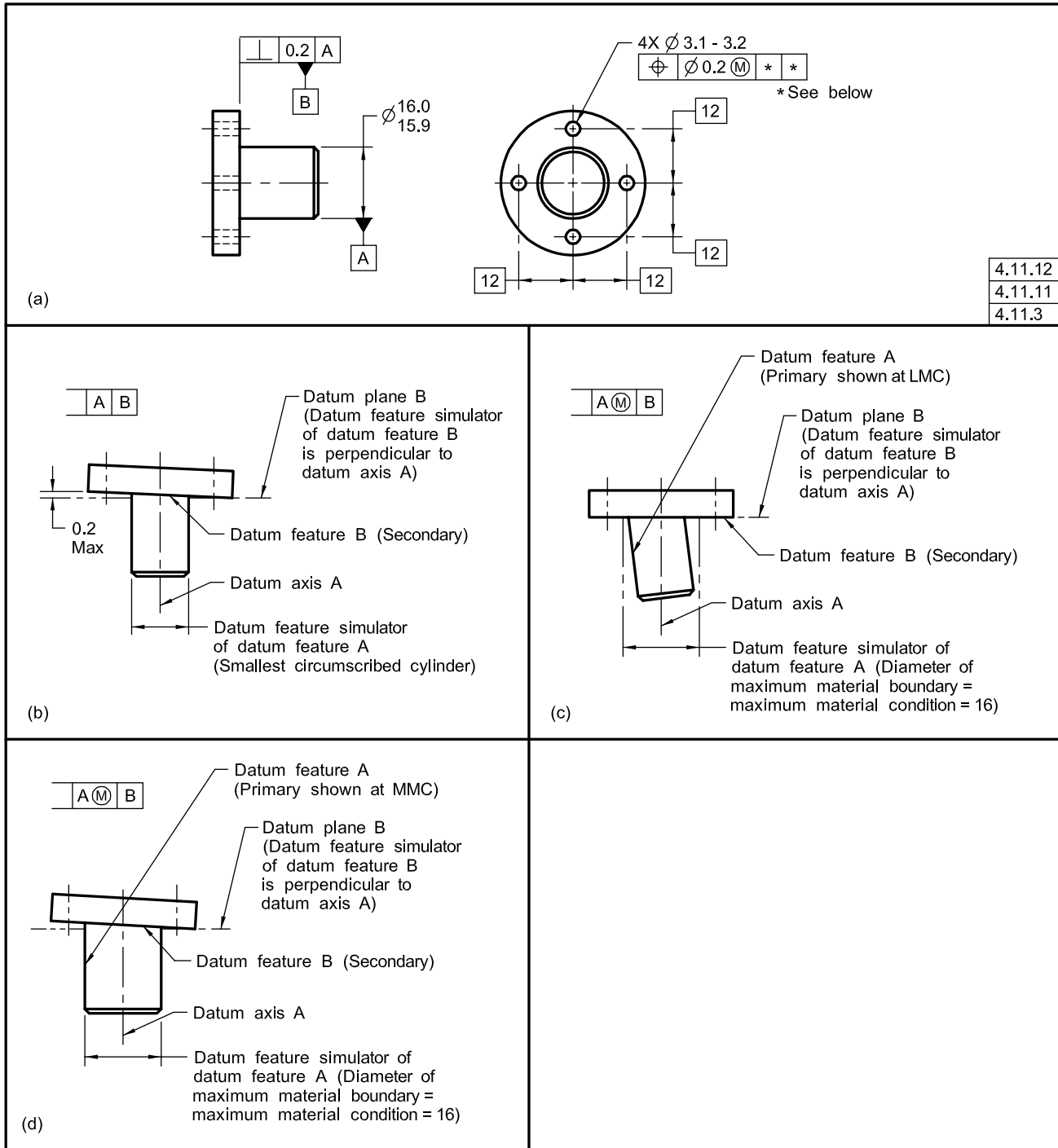
**4.12 MULTIPLE DATUM FEATURES**

Where more than one datum feature is used to establish a datum feature simulator for a single datum, the appropriate datum feature reference letters and associated modifiers, separated by a dash, are entered in one compartment of the feature control frame. See para. 3.4.2 and Fig. 4-22. Since the datum features have equal importance, datum feature reference letters may be entered in any order within this compartment. Where the intent is clear, a datum feature reference letter may be used to define the multiple surfaces as a single datum feature.

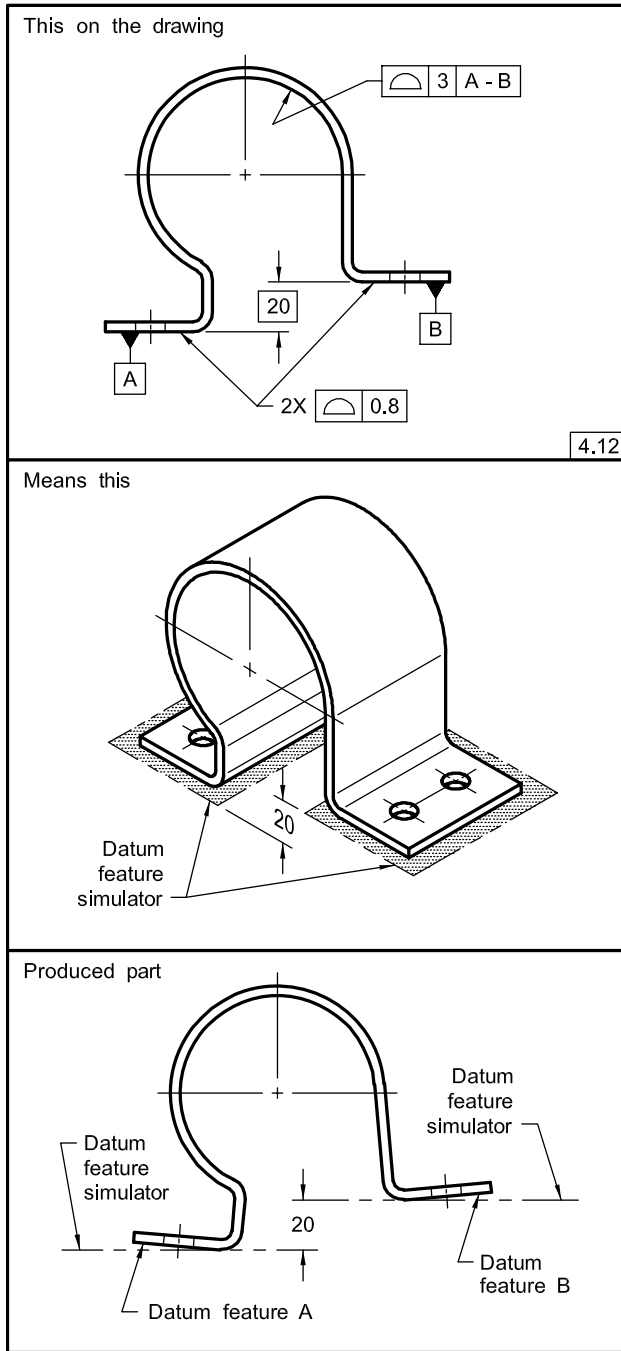
**4.12.1 Simulation of a Single Datum Plane**

Figure 4-23 is an example of a single datum plane simulated, as explained in para. 4.11.1, by coinciding with the datum feature simulator that simultaneously contacts the high points of two surfaces. Identification of two features to establish a single datum plane may be required where separation of the features is caused by an obstruction, such as in Fig. 4-23, or by a comparable opening (e.g., a slot). For controlling coplanarity of these surfaces, see Fig. 4-23 and para. 8.4.1.1. A single datum feature symbol may also be used to indicate that offset surfaces establish a single datum.

Fig. 4-21 Effect of Material Condition



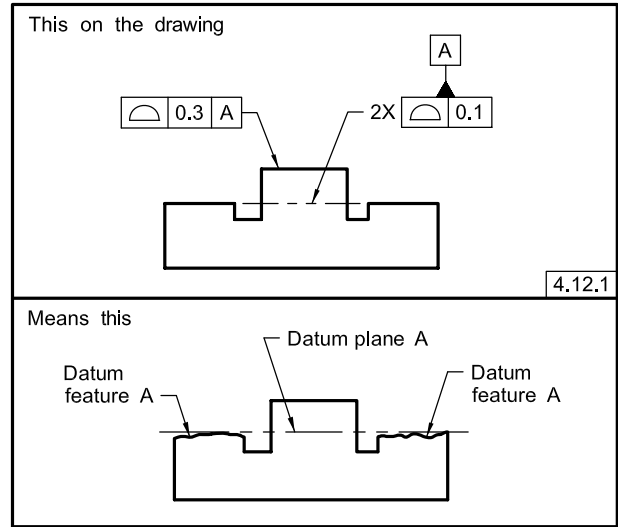
**Fig. 4-22 Planar Multiple Datum**



**4.12.2 Single Axis of Two Coaxial Features of Size**

Figures 4-24 and 4-25 are examples of a single datum axis established from the axes of the datum feature simulators that constrain the two coaxial diameters simultaneously. The datum features in Fig. 4-24 may be at RMB or specified to apply at MMB or LMB as applicable. In Fig. 4-25 the datum features for the runout tolerances can only apply at RMB.

**Fig. 4-23 Two Datum Features Establishing a Single Datum Plane**



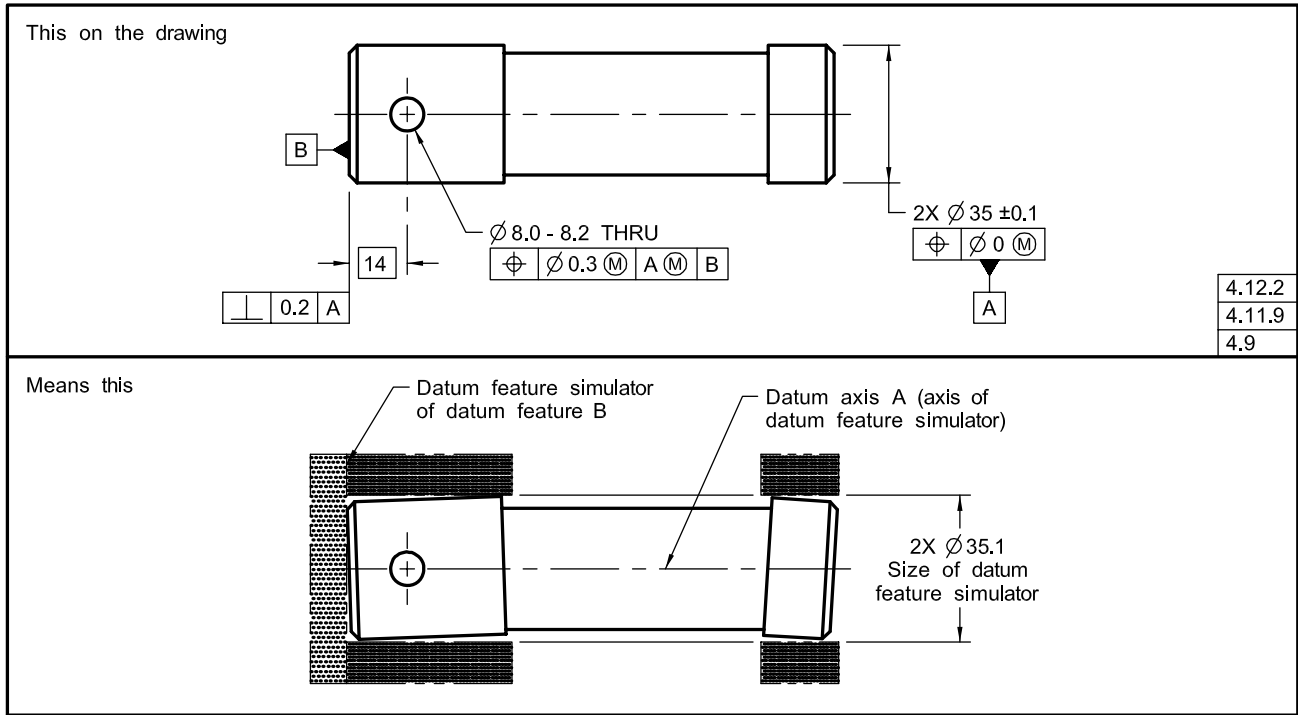
**4.12.3 Pattern of Features of Size at MMB**

Multiple features of size, such as a pattern of holes at MMB, may be used as a group in the establishment of a datum feature simulator to derive a datum reference frame. See Fig. 4-26. In this case, when the part is mounted on the datum feature simulator of primary datum feature A, the pattern of holes establishes the datum feature simulator that is used to derive the second and third planes of the datum reference frame. The datum feature simulator of datum feature B is the collection of the MMB of all of the holes located at true position. The origin of the datum reference frame may be established at the center of the pattern of the datum feature simulator where it intersects plane A, as shown in Fig. 4-26 or at any other location defined with basic dimensions relative to the datum feature simulator as in Fig. 4-28. Where datum feature B is referenced at MMB, a displacement is permitted between the actual hole pattern and the datum reference frame. Such displacement is related to any clearance between the surface of datum feature B and the MMB of each hole. This clearance is determined by the size, orientation, and location of each of the holes collectively.

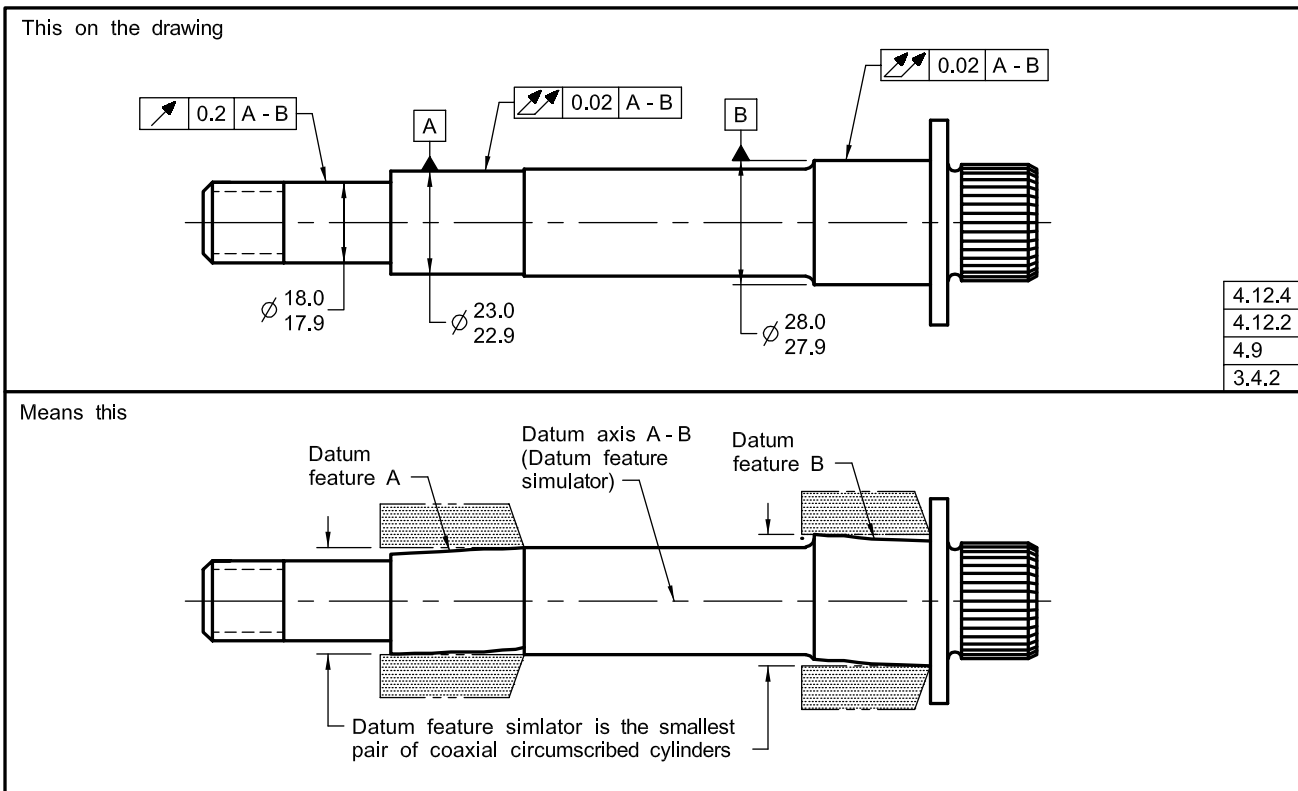
**4.12.4 Pattern of Features of Size at RMB**

Where RMB is applied in a feature control frame to multiple datum features of size used to establish a single datum, the datum feature simulator of each feature shall be fixed in a location relative to one another. The datum feature simulators shall expand or contract simultaneously from their MMB to their LMB until the datum feature simulators make maximum possible contact with the extremities of the datum feature(s). See Fig. 4-25.

**Fig. 4-24 Two Coaxial Datum Features, Single Datum Axis**

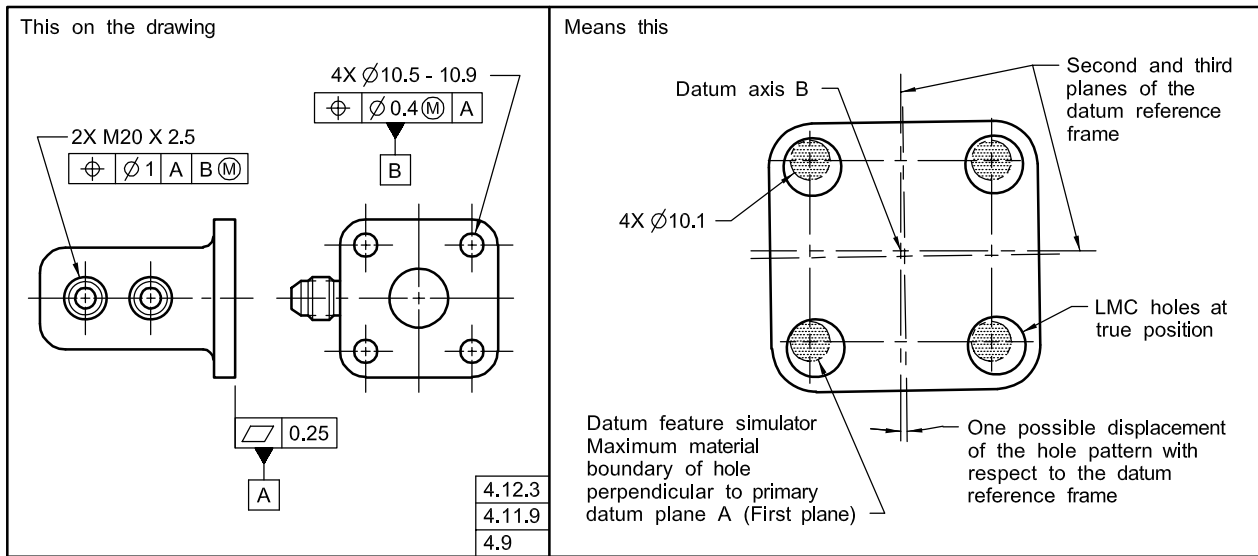


**Fig. 4-25 Two Datum Features at RMB, Single Datum Axis**

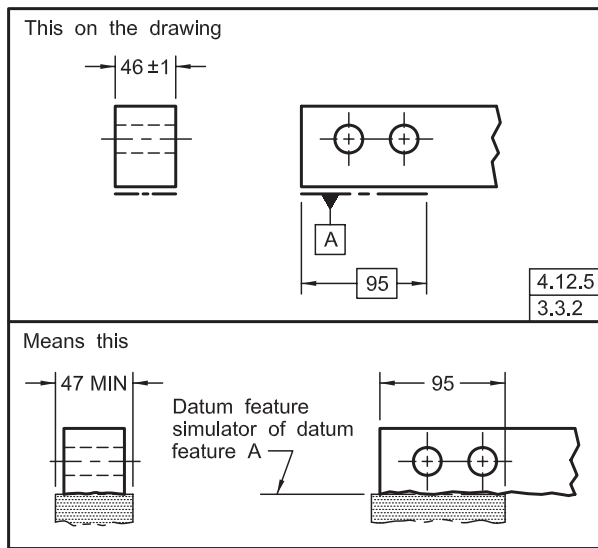




**Fig. 4-26 Hole Pattern Identified as Datum**



**Fig. 4-27 Partial Surface as a Datum Feature**



**4.12.5 Partial Surfaces as Datum Features**

It is often desirable to specify only part of a surface, instead of the entire surface to serve as a datum feature. This may be indicated by means of a chain line (2D orthographic drawing only) drawn parallel to the surface profile (dimensioned for length and location) as in Fig. 4-27, specified in note form, or by a datum target.

**4.13 MATHEMATICALLY DEFINED SURFACE**

It is sometimes necessary to identify a compound curve or a contoured surface as a datum feature. A mathematically defined feature shall be defined within a three-dimensional coordinate system. Where such a

feature is specified as a datum feature, its datum feature simulator (derived from the math data) is used in establishing the datum reference frame. Aligning the high points of the datum feature with its datum feature simulator restricts movement of the part to the datum reference frame. Where the datum feature alone will not adequately restrict the required degrees of freedom of the part, additional datum features will be required. See Fig. 4-28.

NOTE: If the datum feature is specified to apply at MMB as in Fig. 4-28 or LMB, the math data is adjusted by the value of the tolerance applicable at that boundary to determine the datum feature simulator.

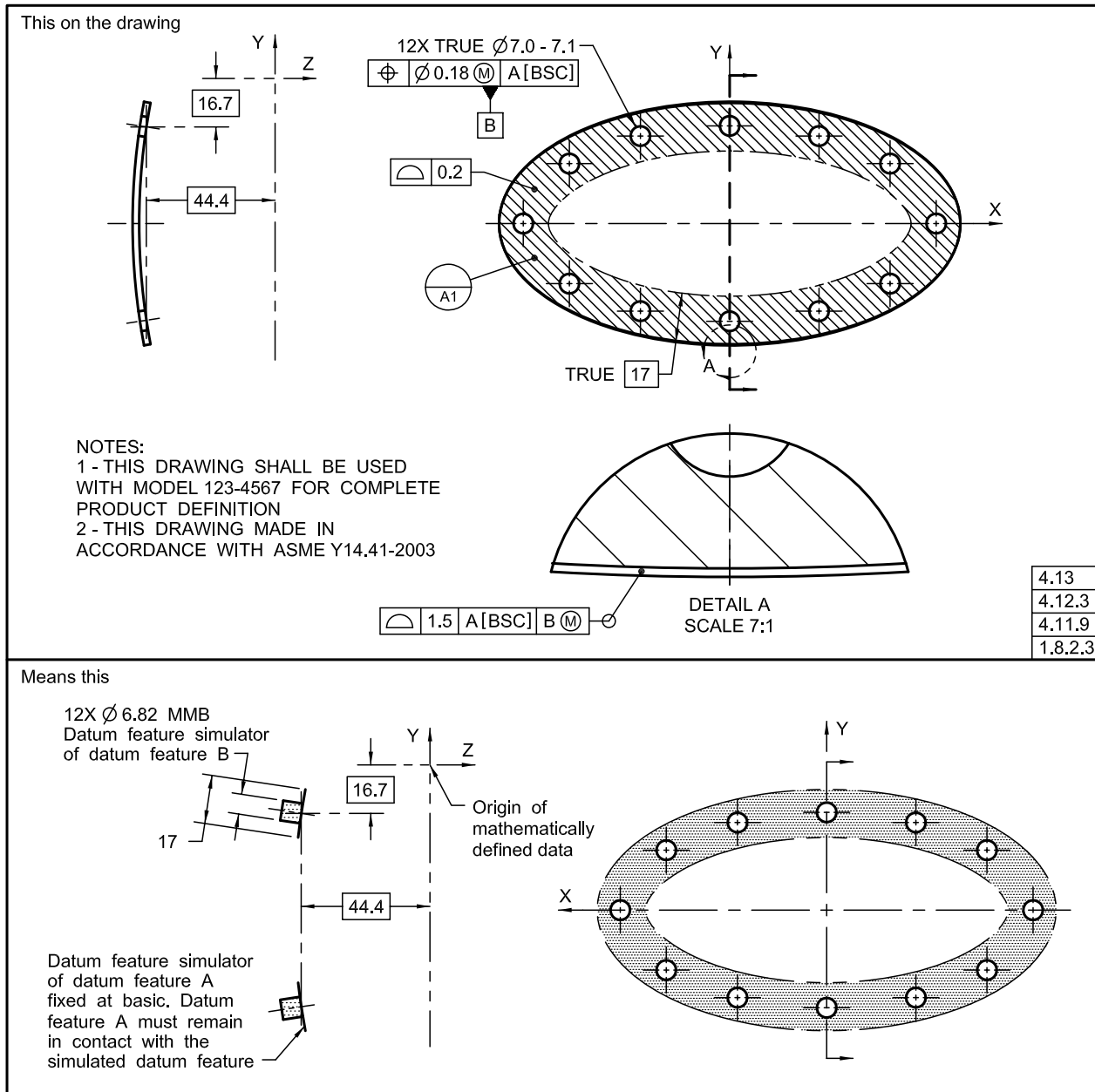
**4.14 MULTIPLE DATUM REFERENCE FRAMES**

More than one datum reference frame may be necessary for certain parts, depending upon functional requirements. Where more than one datum reference frame is used and it is necessary to determine the relationships and calculate boundaries between the reference frames, the relationship between the datum reference frames shall be specified. In Fig. 4-4, datum features A and B establish one datum reference frame, while datum features C and D establish a different datum reference frame.

**4.15 FUNCTIONAL DATUM FEATURES**

Only the required datum features should be referenced in feature control frames when specifying geometric tolerances. An understanding of the geometric control provided by these tolerances (as explained in Sections 5 through 9) is necessary to determine effectively the number of datum feature references required for a given application. The functional requirements of the design

Fig. 4-28 Contoured Surface as a Datum Feature



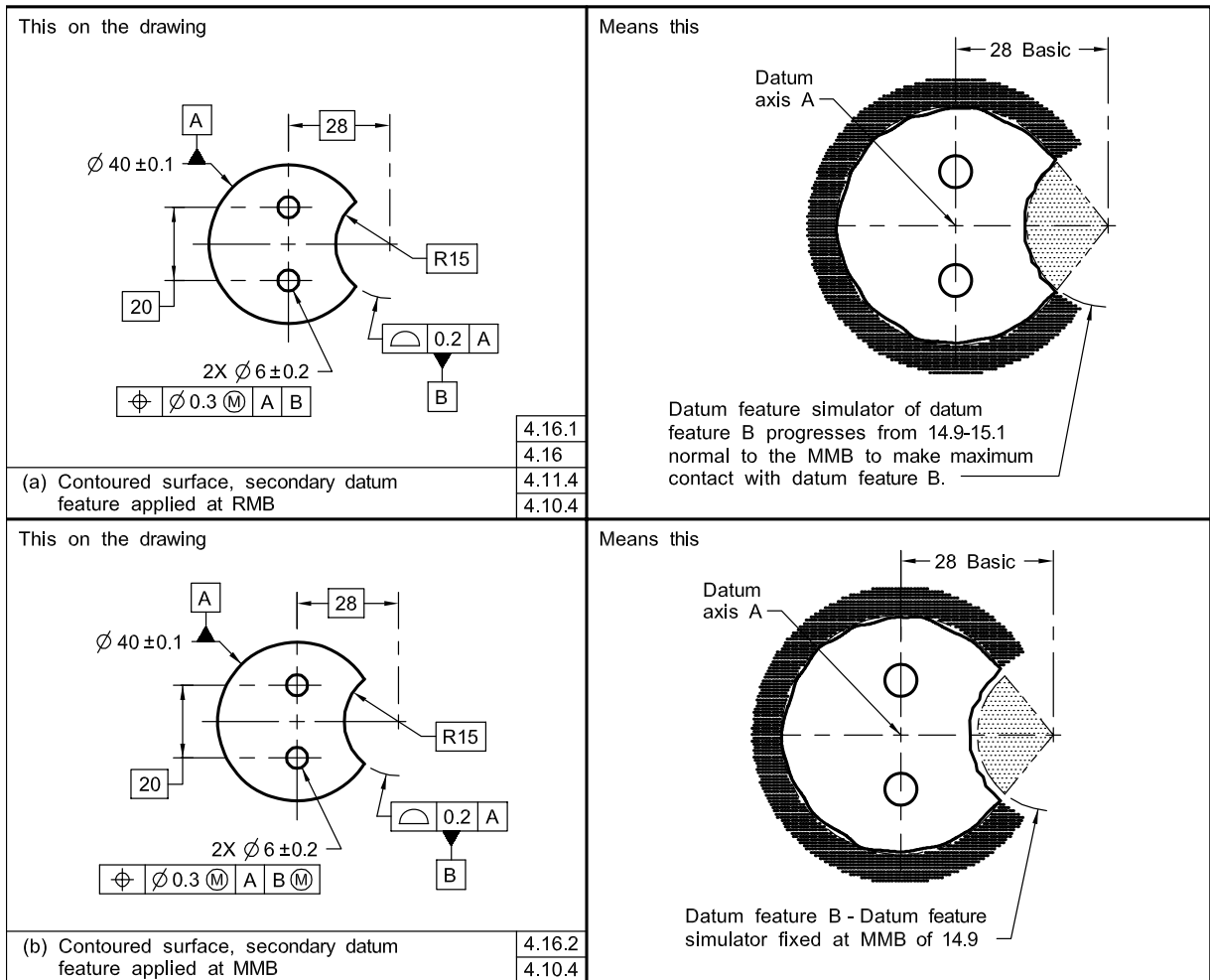
should be the basis for selecting the related datum features to be referenced in the feature control frame. Figures 4-36 through 4-38 illustrate parts in an assembly where geometric tolerances are specified, each having the required number of datum feature references.

#### 4.16 ROTATIONAL CONSTRAINT ABOUT A DATUM AXIS OR POINT

Where a datum reference frame is established from a primary or secondary datum axis or point, a lower precedence datum feature surface or feature of size may be used to constrain rotation. See para. 4.10.4. Depending

on functional requirements, there are many ways to constrain the rotational degrees of freedom about the higher precedence datum. Figures 4-8 and 4-29 through 4-32 illustrate the development of a datum reference frame based on the principles outlined in the datum feature simulator requirements. In these figures, datum feature A establishes an axis. The lower precedence datum feature B is located (positioned or profiled) to datum feature A and is then used to orient the rotational degrees of freedom to establish the datum reference frame that is used to locate the two 6-mm diameter holes. Depending on functional requirements, this lower precedence datum feature may apply at RMB or be modified

**Fig. 4-29 Contoured Datum Feature Constraining a Rotational Degree of Freedom**



to apply at MMB or LMB. The datum reference frame is established from the datum feature simulators and not the datum features.

**4.16.1 Contoured Datum Feature at RMB Constraining a Rotational Degree of Freedom**

In Fig. 4-29, illustration (a), datum feature B applies at RMB. This requires the datum feature simulator geometry to originate at the MMB of R14.9 mm and progress through the profile tolerance zone toward the LMB of R15.1 mm until it makes maximum contact with datum feature B and constrains the rotational degree of freedom of the part around the axis of the datum feature simulator from datum feature A.

**4.16.2 Contoured Datum Feature at MMB Constraining a Rotational Degree of Freedom**

In Fig. 4-29, illustration (b), datum feature B is modified to apply at MMB. This requires the datum feature simulator to be fixed at the MMB of R14.9 mm and thus orients the two planes that originate at the axis of the

datum feature simulator of datum feature A. Datum feature B may rotate within the confines created by its departure from MMB and might not remain in contact with the datum feature simulator.

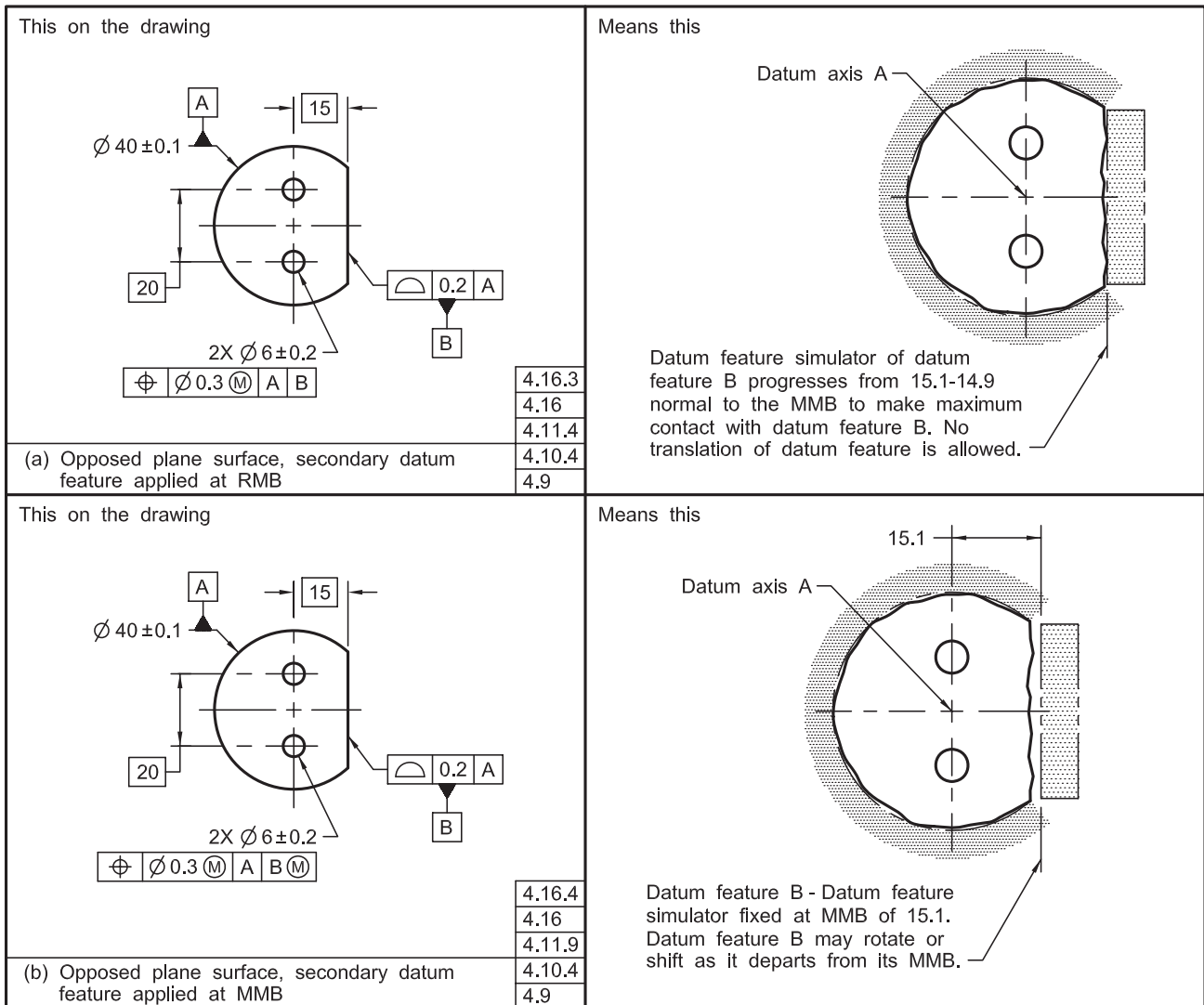
**4.16.3 Planar Datum Feature at RMB Constraining a Rotational Degree of Freedom**

In Fig. 4-30, illustration (a), datum feature B applies at RMB. This requires the datum feature simulator geometry to originate at MMB of 15.1 mm and progress through the profile tolerance zone toward the LMB of 14.9 mm until it makes maximum contact with datum feature B and constrains the rotational degree of freedom of the part around the axis of the datum feature simulator of datum feature A.

**4.16.4 Planar Datum Feature at MMB Constraining a Rotational Degree of Freedom**

In Fig. 4-30, illustration (b), datum feature B is modified to be fixed at the MMB of 15.1 mm and thus

**Fig. 4-30 Planar Datum Feature Constraining a Rotational Degree of Freedom**



orients the two planes that originate at the axis of the datum feature simulator of datum feature A. Datum feature B may rotate within the confines created by its departure from MMB and might not remain in contact with the datum feature simulator.

**4.16.5 Offset Planar Datum Feature at RMB Constraining a Rotational Degree of Freedom**

In Fig. 4-31, illustration (a), datum feature B is offset relative to datum axis A and applies at RMB. This requires the datum feature simulator geometry to originate at MMB of 5.1 mm and progress through the profile tolerance zone toward the LMB of 4.9 mm until it makes maximum contact with datum feature B (possible two point contact) and constrains the rotational degree of freedom of the two planes of the datum reference frame around the axis of the true geometric counterpart of datum feature A.

**4.16.6 Offset Planar Datum Feature Set at Basic Constraining a Rotational Degree of Freedom**

In Fig. 4-31, illustration (b), datum feature B is offset 5 mm relative to datum axis A. RMB does not apply as it is overridden in the feature control frame for the two holes by the abbreviation BSC in brackets following the reference to datum feature B. See para. 4.11.6.3. This requires the datum feature simulator to be fixed at 5 mm basic and constrains the rotational degree of freedom of the two planes of the datum reference frame around the axis of the datum feature simulator from datum feature A.

**4.16.7 Offset Planar Datum Feature at MMB Constraining a Rotational Degree of Freedom**

In Fig. 4-31, illustration (c), datum feature B is offset relative to datum axis A and modified to apply at MMB. This requires the datum feature simulator to be fixed

Fig. 4-31 Datum Modifier Effects — Plane Surface

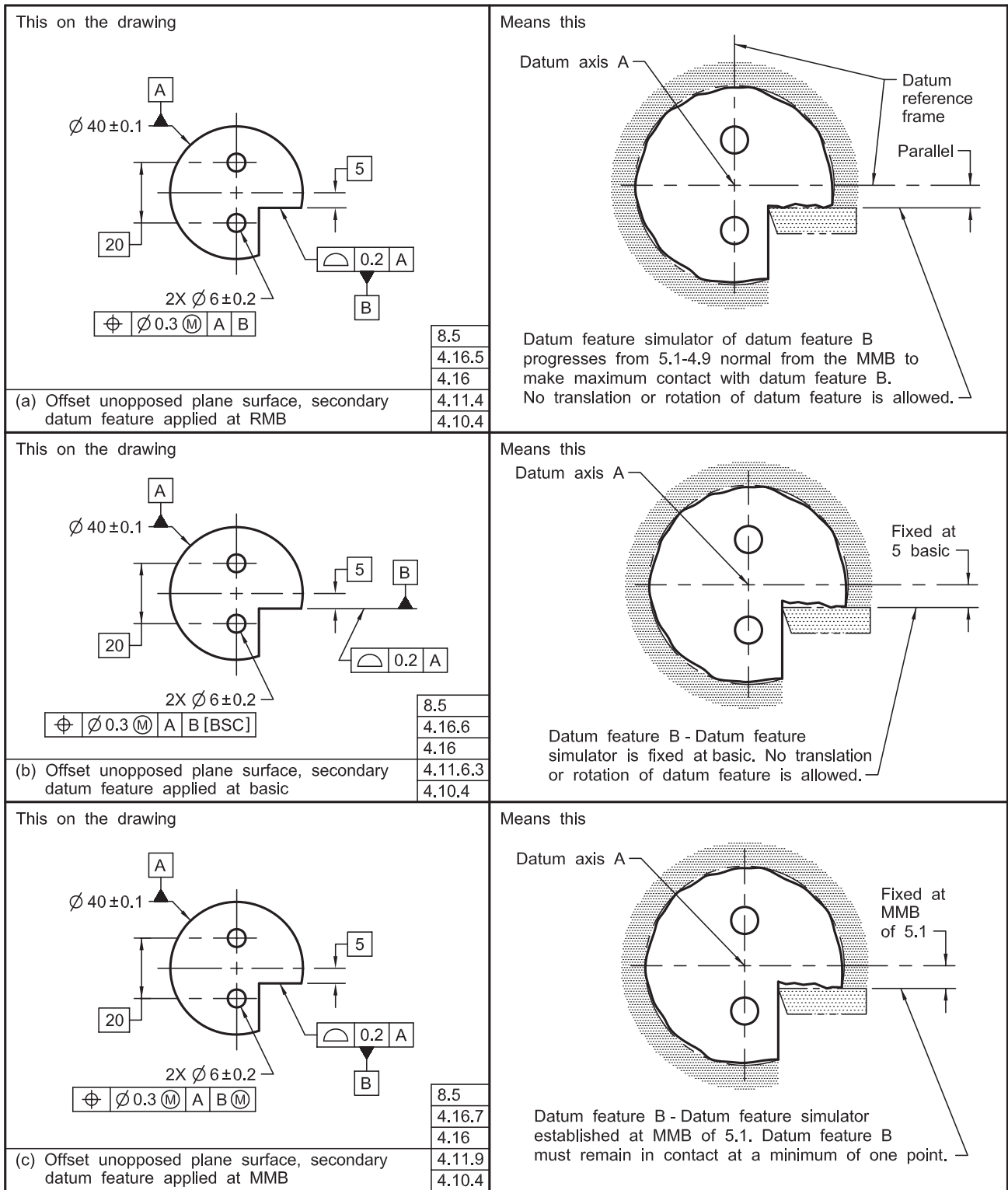
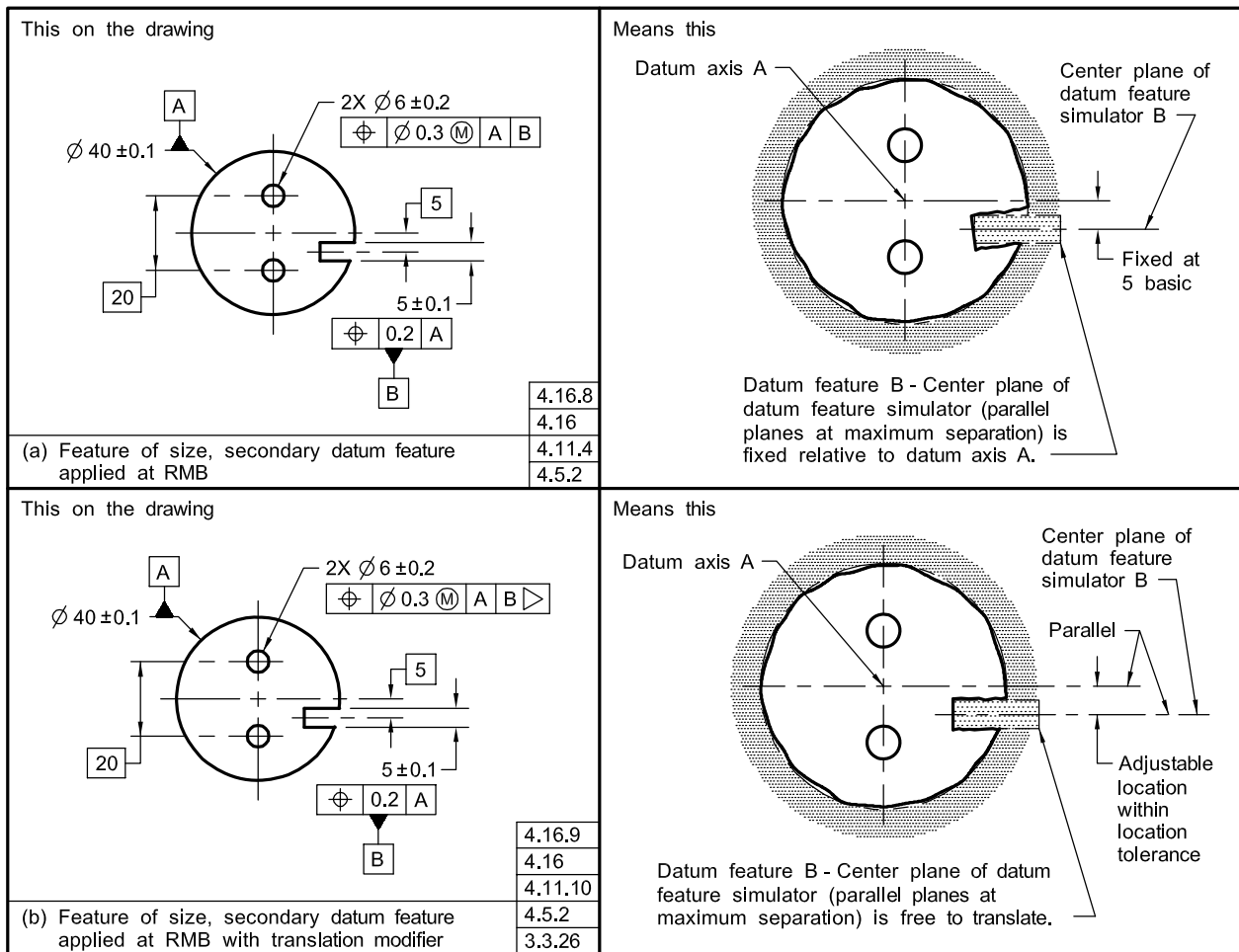


Fig. 4-32 Datum Modifier Effects — Size Feature



at the MMB of 5.1 mm and constrains the rotational degree of freedom of the two planes of the datum reference frame that originate at the datum feature reference of datum feature A. Where the datum feature simulator and the higher precedence datum axis do not limit rotation in both directions about the datum axis, the datum feature must always contact the datum feature simulator.

**4.16.8 Datum Feature of Size at RMB Constraining a Rotational Degree of Freedom**

In Fig. 4-32, illustration (a), datum feature B applies at RMB and is located relative to datum axis A. This requires the center plane of the datum feature simulator geometry to be fixed at the basic 5 mm dimension and the datum feature simulator geometry to expand until it makes maximum contact with datum feature B. This constrains the rotational degree of freedom of the two planes of the datum reference frame around the axis of the datum feature simulator of datum feature A.

**4.16.9 Datum Feature of Size at RMB With Translation Modifier Constraining Rotational Degrees of Freedom**

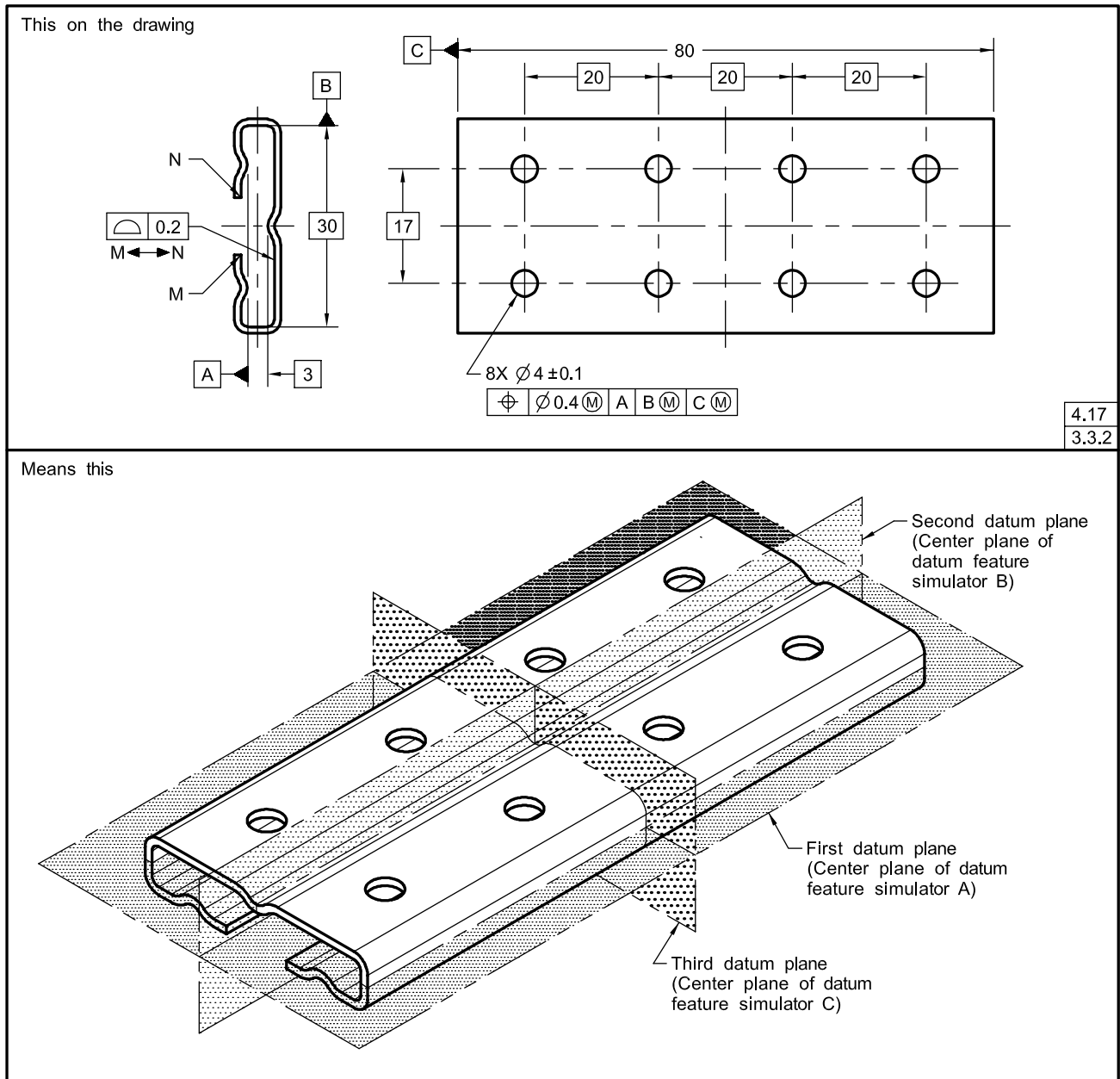
In Fig. 4-32, illustration (b), datum feature B applies at RMB with a translation modifier. This allows the center plane of the datum feature simulator to translate while maintaining its orientation to higher precedence datums. The parallel planes of the datum feature simulator expand to make maximum contact with the datum feature.

**4.17 APPLICATION OF MMB, LMB, AND RMB TO IRREGULAR FEATURES OF SIZE**

MMB, LMB, and RMB may be applied to irregular features of size when they are selected as datum features.

(a) In some applications, irregular features of size that contain or may be contained by an actual mating envelope or actual minimum material envelope from which a center point, an axis, or a center plane can be derived

**Fig. 4-33 Irregular and Regular Features of Size Datum Features**



may be used as datum features. See para. 1.3.32.2(a) and Figs. 4-33, 4-34, and 4-35. RMB, MMB, and LMB principles may be applied to these types of irregular features of size.

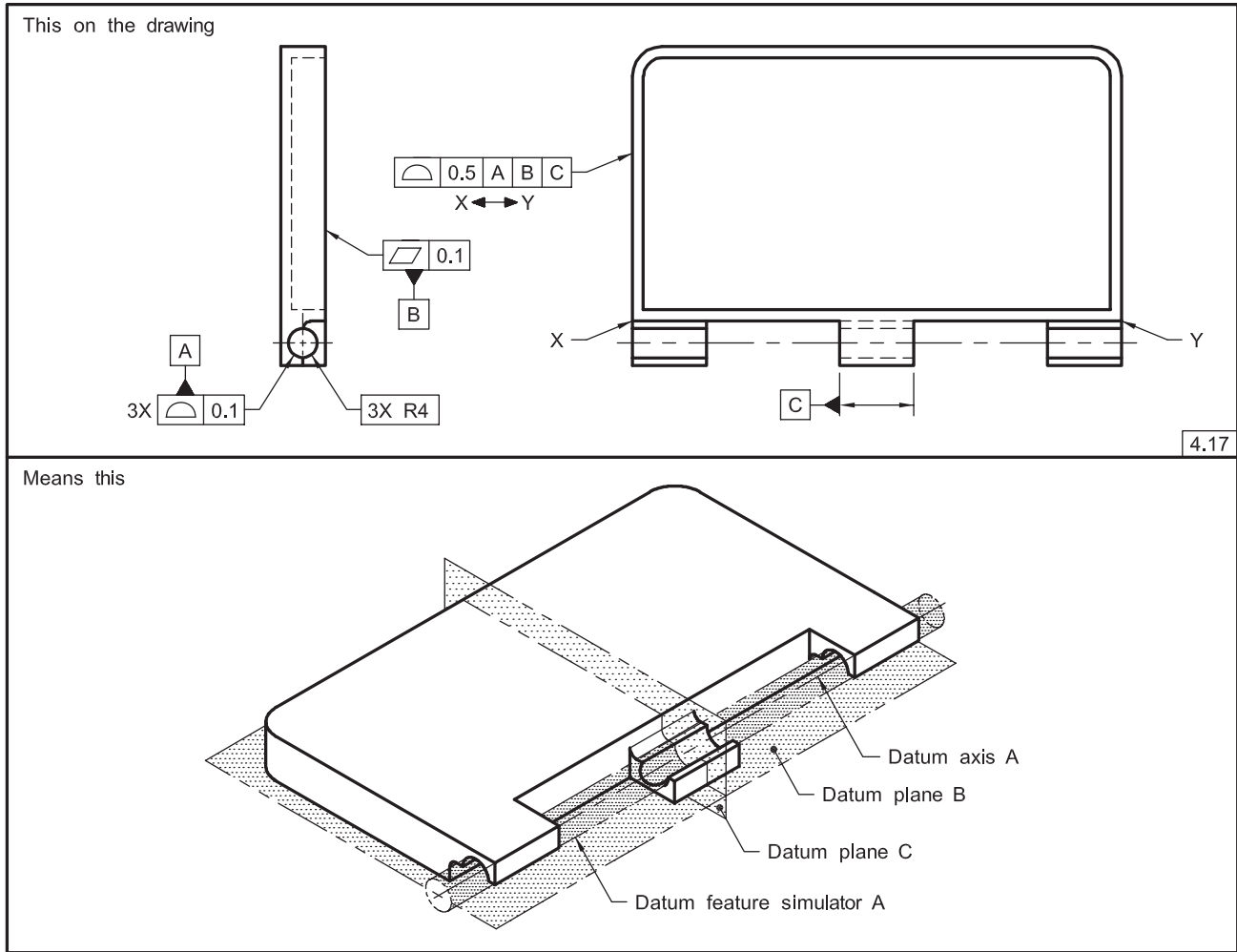
(b) In other applications (such as an irregular shaped feature) where a boundary has been defined using profile tolerancing, a center point, an axis, or a center plane may not be readily definable. See para. 1.3.32.2(b) and Fig. 8-24. MMB and LMB principles may be applied to this type of irregular feature of size. When RMB is

applied, the fitting routine may be the same as for a regular feature of size, a specific fitting routine may be defined, or datum targets may be used.

#### 4.18 DATUM FEATURE SELECTION PRACTICAL APPLICATION

Figure 4-36 illustrates an assembly of mating parts. Datum features were selected based on functional assembly and mating conditions. Figure 4-37 illustrates the

Fig. 4-34 Coaxial Irregular Feature of Size Datum Feature



pulley and the datum features selected based on the functional interrelationship with the adapter in the assembly. The internal bore on the pulley is selected as the primary datum feature (identified as A) based on the amount of contact it has with the pilot diameter of the adapter. The shoulder has the secondary contact with the adapter, and it is selected as secondary datum feature (identified as B). The assembly of the pulley to the adapter depends on the clamping of the bolt and washer, and a tertiary datum feature is not necessary. Figure 4-38 illustrates the adapter with its datum features and appropriate geometric tolerances based on function. An analysis of the relationship between the adapter and the crankshaft indicates that the shoulder has the most contact with the crankshaft; and because the bolt force on the assembly will load the shoulder surface plane into contact with the end of the crankshaft, establishing an initial orientation, it is selected as the primary datum feature (identified as A). Secondary contact is between the pilot on the adapter and the bore on the crankshaft, and, therefore, the pilot is

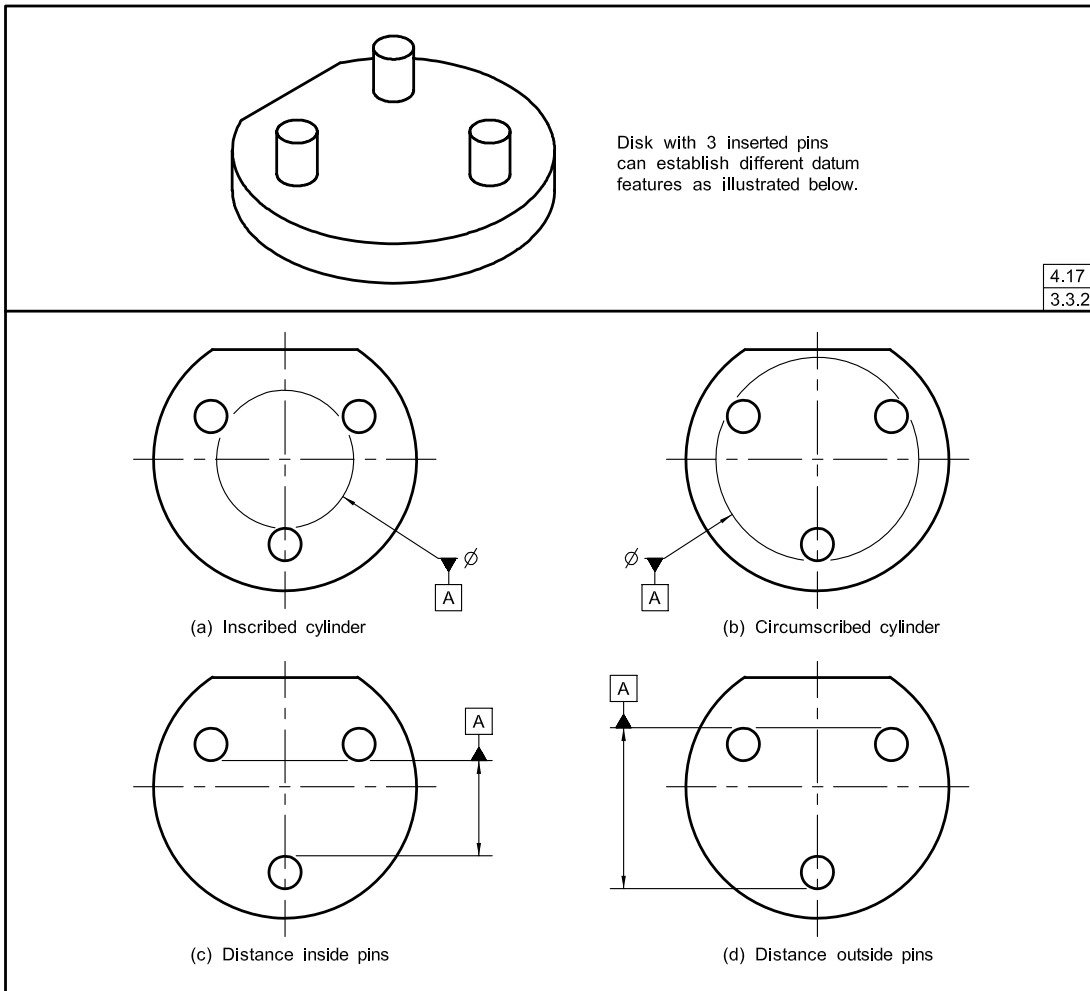
selected as the secondary datum feature (identified as B) for the adapter. In this example, a tertiary datum feature is unnecessary as the rotation is constrained by the five clearance holes, and other features on the part do not need to be controlled for rotation. Selection of datum features in this manner minimizes tolerance accumulation within an assembly and is also representative of actual function.

#### 4.19 SIMULTANEOUS REQUIREMENTS

A simultaneous requirement is where two or more geometric tolerances apply as a single pattern or part requirement. A simultaneous requirement applies to position and profile tolerances that are located by basic dimensions, related to common datum features referenced in the same order of precedence at the same boundary conditions. In a simultaneous requirement there is no translation or rotation between the datum reference frames of the included geometric tolerances,



**Fig. 4-35 Datum Possibilities From Three Pins for an Irregular Feature of Size**



**Fig. 4-36 Mating Parts for Functional Datum Selection**

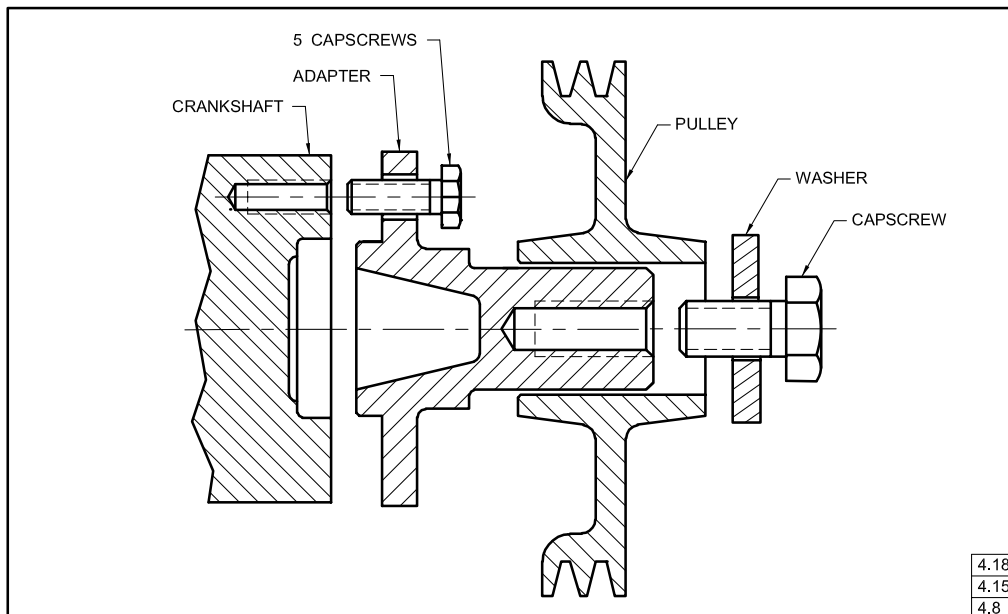


Fig. 4-37 Functional Datum Application — Pulley

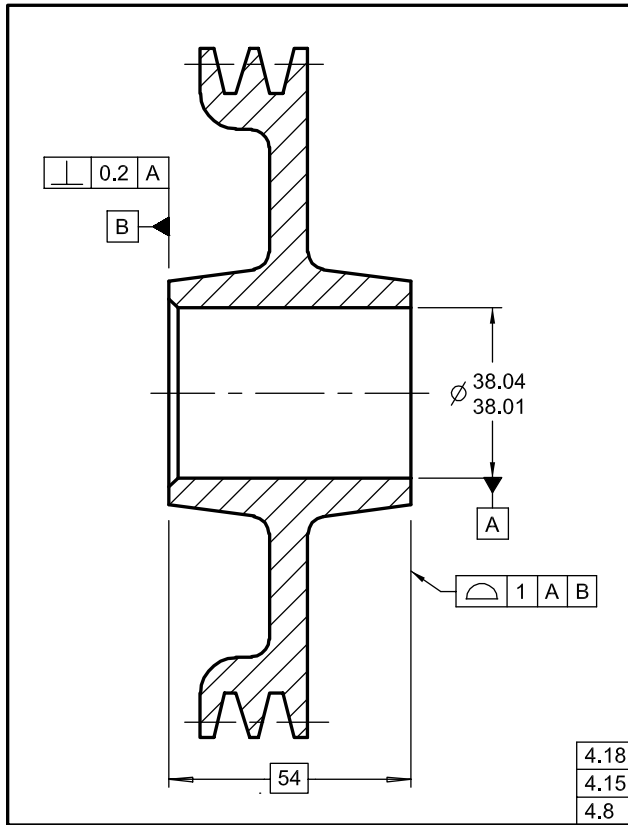
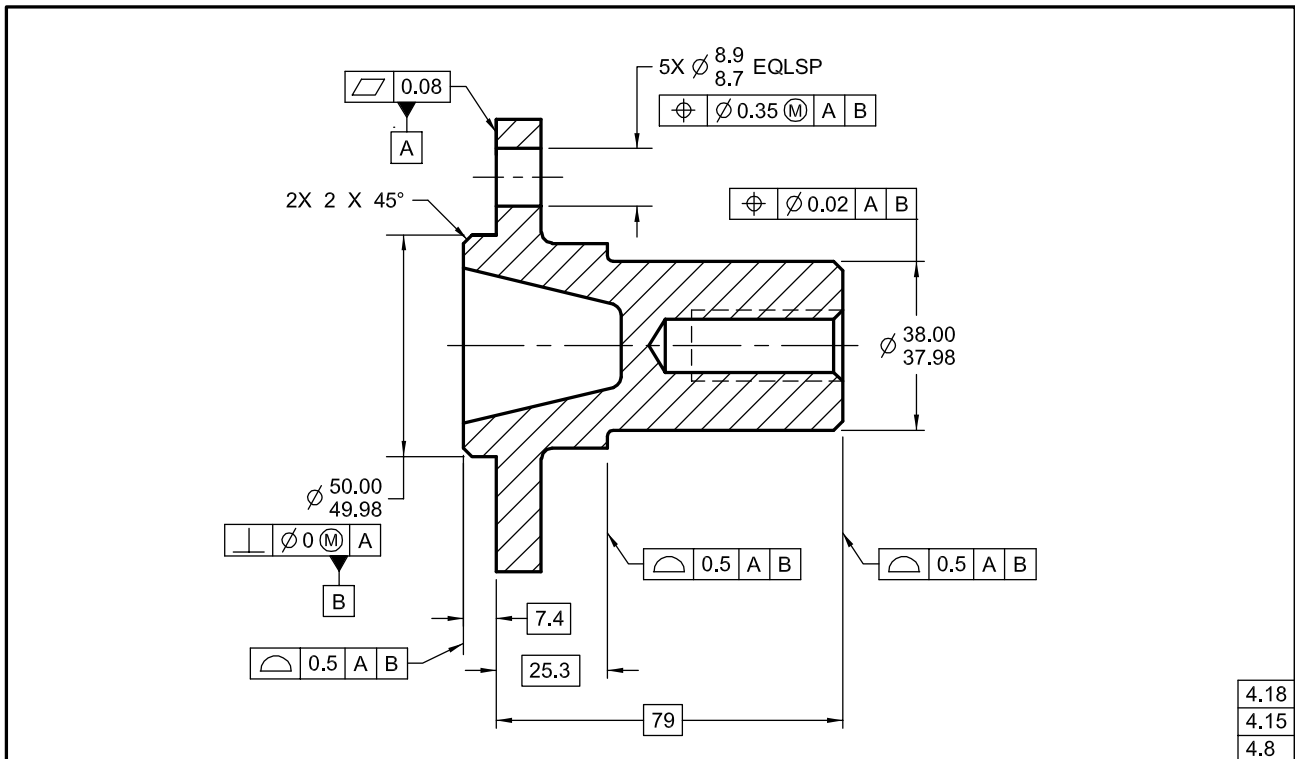
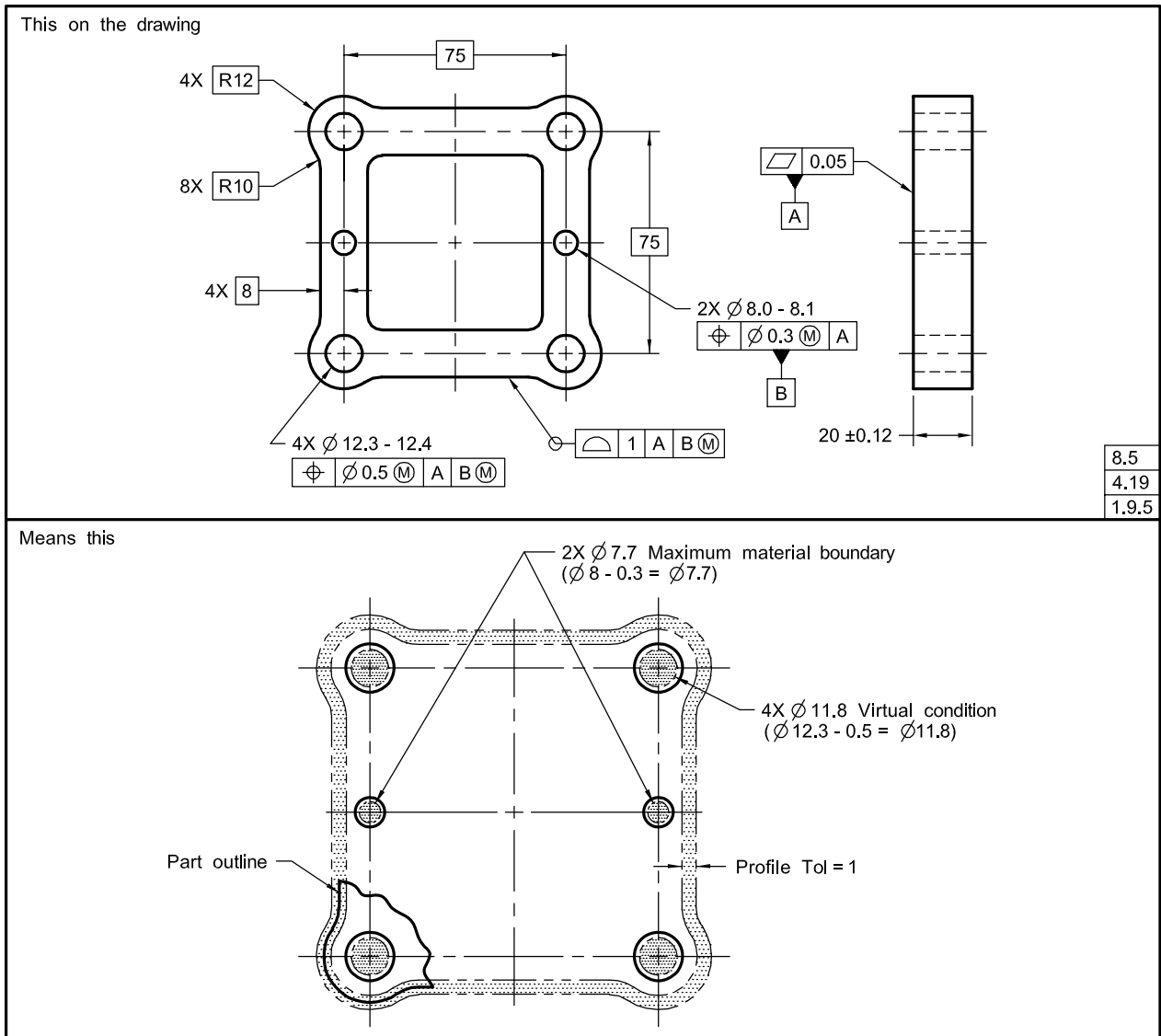


Fig. 4-38 Functional Datum Application — Adapter



**Fig. 4-39 Simultaneous Position and Profile Tolerances**



thus creating a single pattern. Figures 4-39 and 4-40 show examples of simultaneous requirements. If such interrelationship is not required, a notation such as **SEP REQT** is placed adjacent to each applicable feature control frame. See Figs. 4-41 and 7-54 and para. 7.5.4.2. This principle does not apply to the lower segments of composite feature control frames. See para. 7.5.4.2. If a simultaneous requirement is desired for the lower segments of two or more composite feature control frames, a notation such as **SIM REQT** shall be placed adjacent to each applicable lower segment of the feature control frames.

**4.20 RESTRAINED CONDITION**

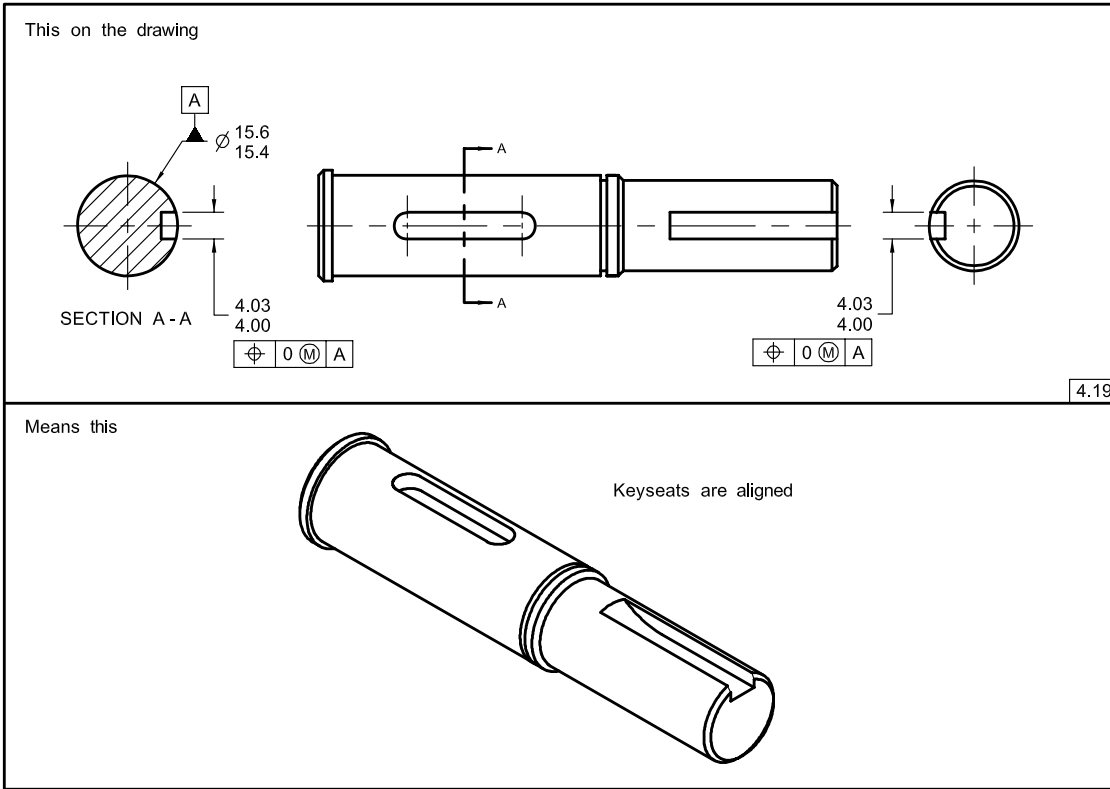
Unless otherwise specified, all tolerances apply in a free-state condition. In some cases, it may be desirable to restrain a part on its datum features to simulate their

function or interaction with other features or parts. To invoke a restrained condition, a note is specified or referenced on the drawing defining the specific requirements. See Fig. 4-42. This figure illustrates a part that should be restrained until sufficient reinforcement is added to retain its design shape. In this illustration, the restraint must be per a document referenced on the drawing. In a restrained application, it is permissible to use as many datum targets as necessary to establish the datum features.

**4.21 DATUM REFERENCE FRAME IDENTIFICATION**

Where a datum reference frame has been properly established and it is considered necessary to illustrate the axes of a datum reference frame on the drawing, the axes or center planes may be labeled to determine

**Fig. 4-40 Aligned Features — Simultaneous Requirement**



**Fig. 4-41 Pattern of Features Not Aligned — Specified Separate Requirements**

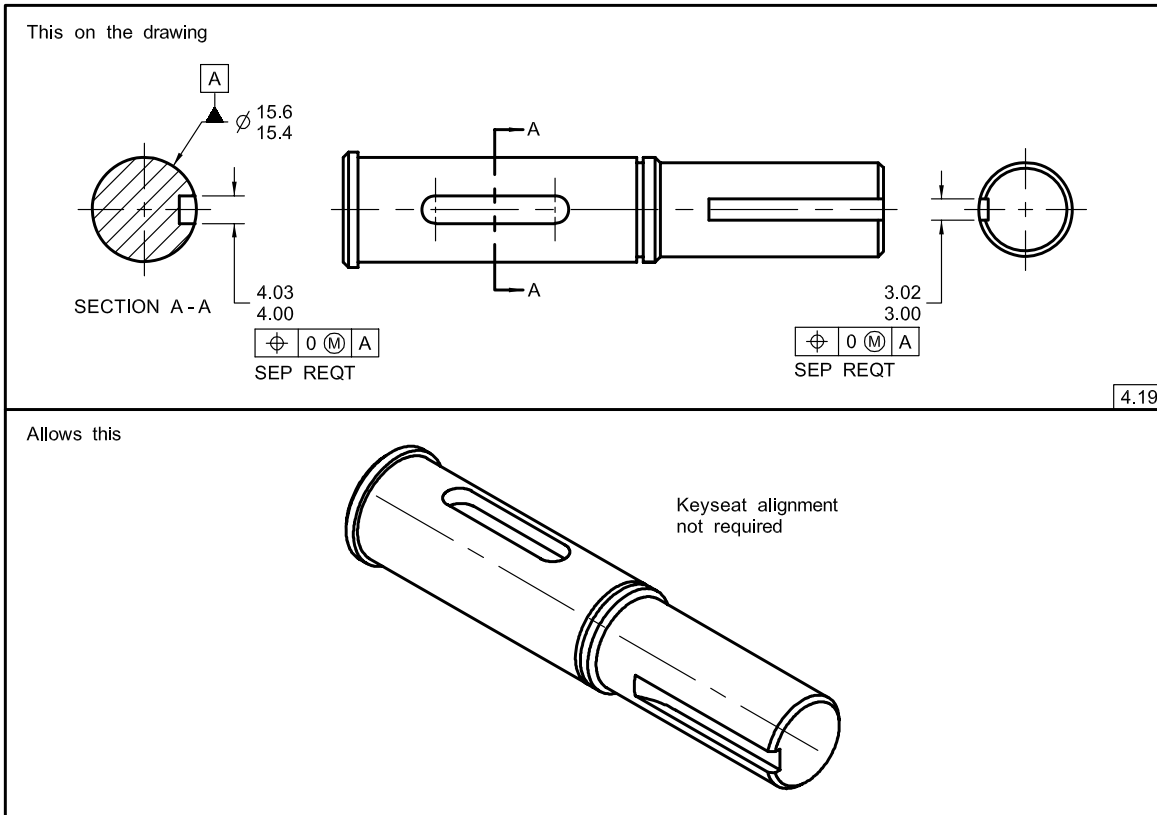
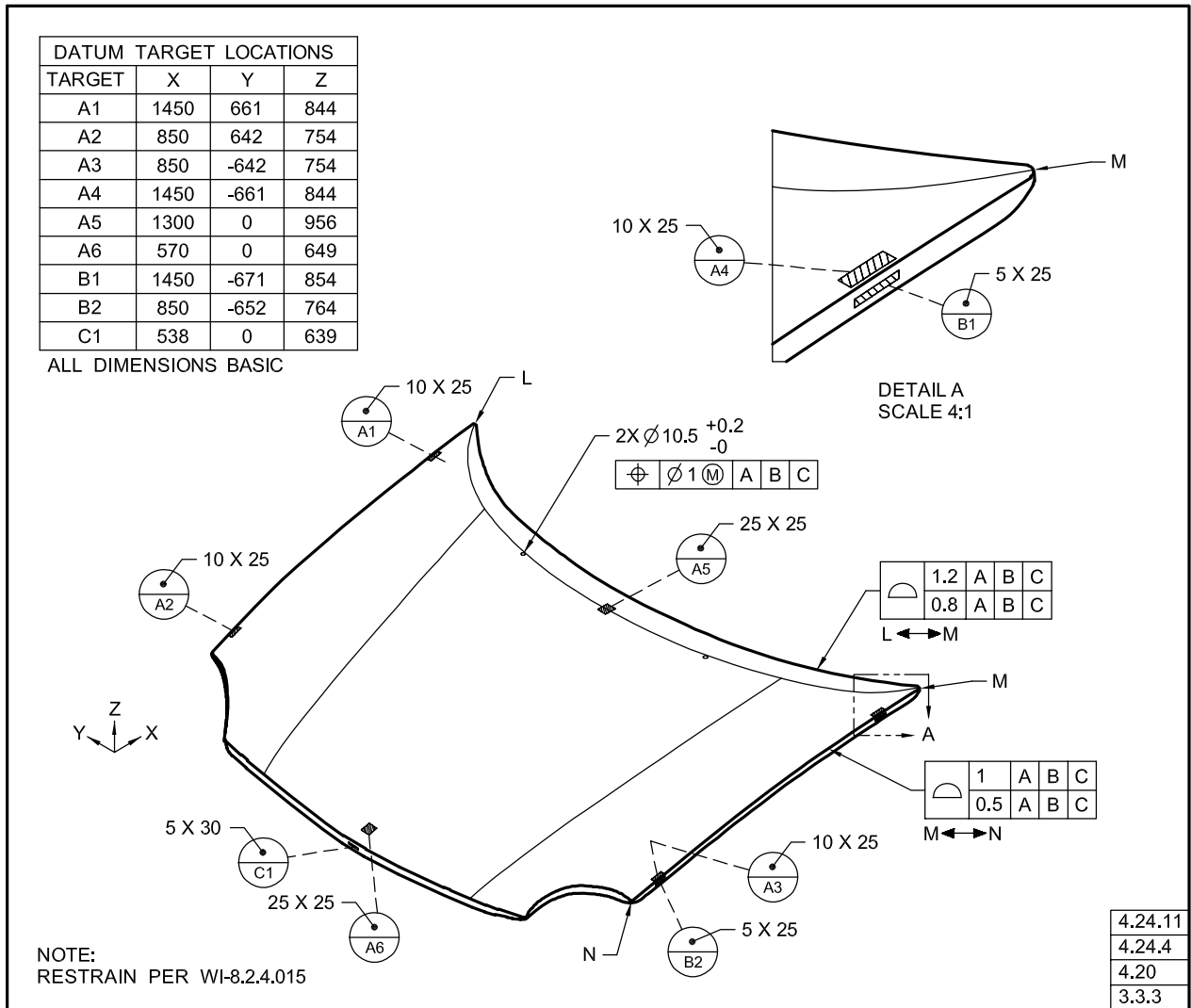


Fig. 4-42 Restrained Condition Application



the translational degrees of freedom X, Y, and Z. See Figs. 4-2, 4-7, 4-8, and 4-54. Where multiple datum reference frames exist, and it is desirable to label the axes (X, Y, and Z), any labeled axes shall include a reference to the associated datum reference frame. In Fig. 4-43 the X, Y, and Z axes for the three datum reference frames are identified by the notation [A, B, C], [A, B, D], and [A, B, E]. These labels represent the datum reference frames (without modifiers) for each datum reference frame and follow the X, Y, and Z identification letters.

**4.22 CUSTOMIZED DATUM REFERENCE FRAME CONSTRUCTION**

To override the degrees of freedom constrained by datum features referenced in an order of precedence, a customized datum reference frame may be invoked. When applying the customized datum reference frame,

the following requirements govern the constraint on each datum feature reference:

- (a) the rectangular coordinate axes shall be labeled in at least two views on the drawing. See Figs. 4-44 and 4-45.
- (b) the degree(s) of freedom to be constrained by each datum feature referenced in the feature control frame shall be explicitly stated by placing the designated degree of freedom to be constrained in lowercase letter(s) [X, Y, Z, u, v, or w] in brackets following each datum feature reference and any applicable modifier(s). See Figs. 4-45 and 4-46.

**4.23 APPLICATION OF A CUSTOMIZED DATUM REFERENCE FRAME**

In Fig. 4-44 the conical primary datum feature A constrains five degrees of freedom, including translation

Fig. 4-43 Datum Reference Frame Identification

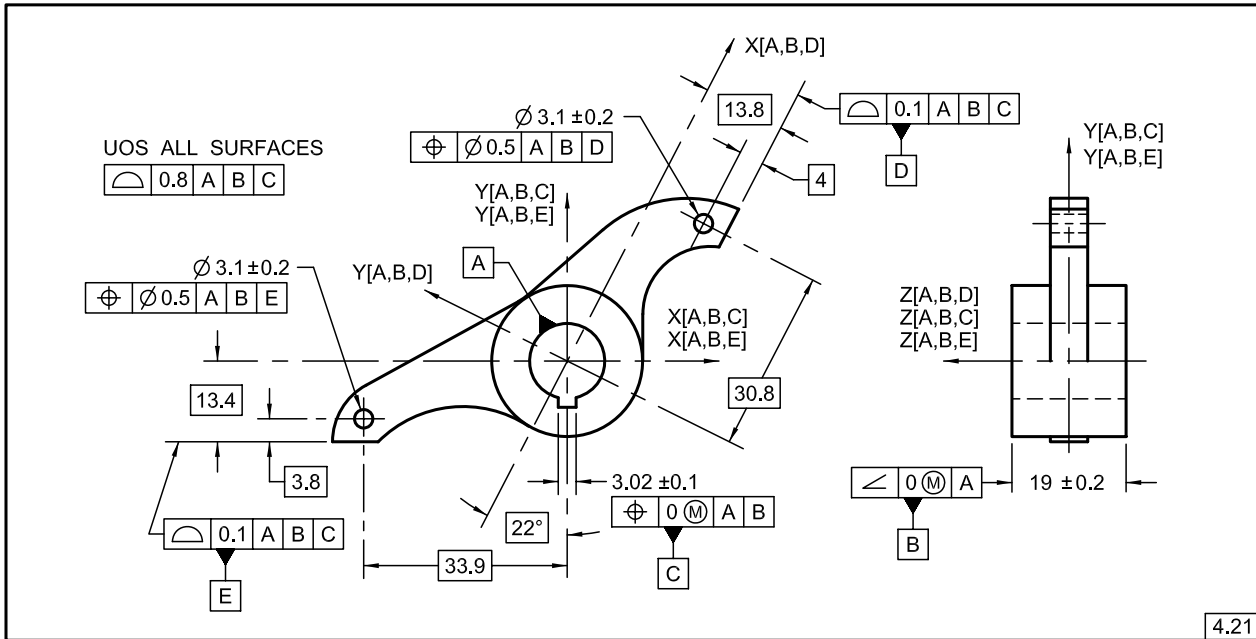


Fig. 4-44 Conical Datum Feature

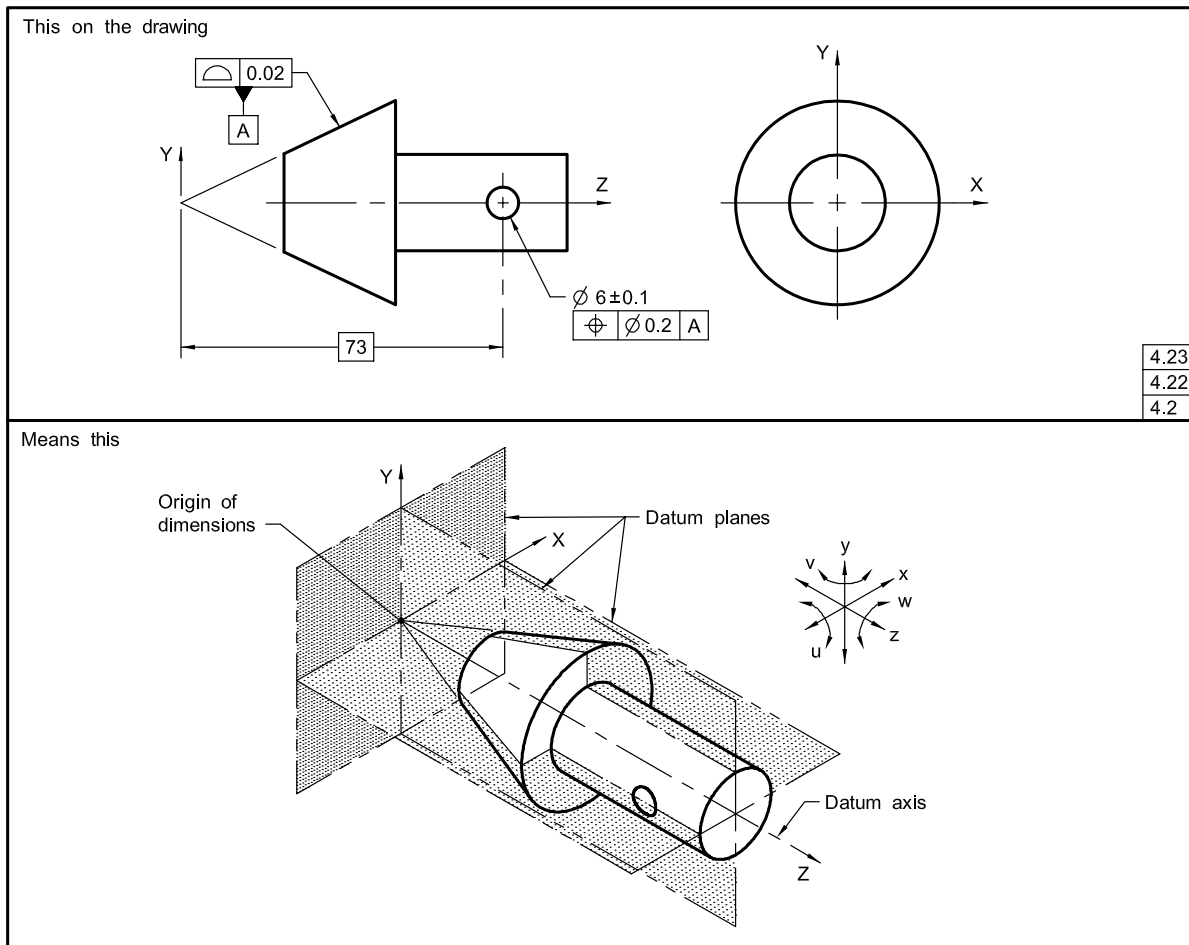
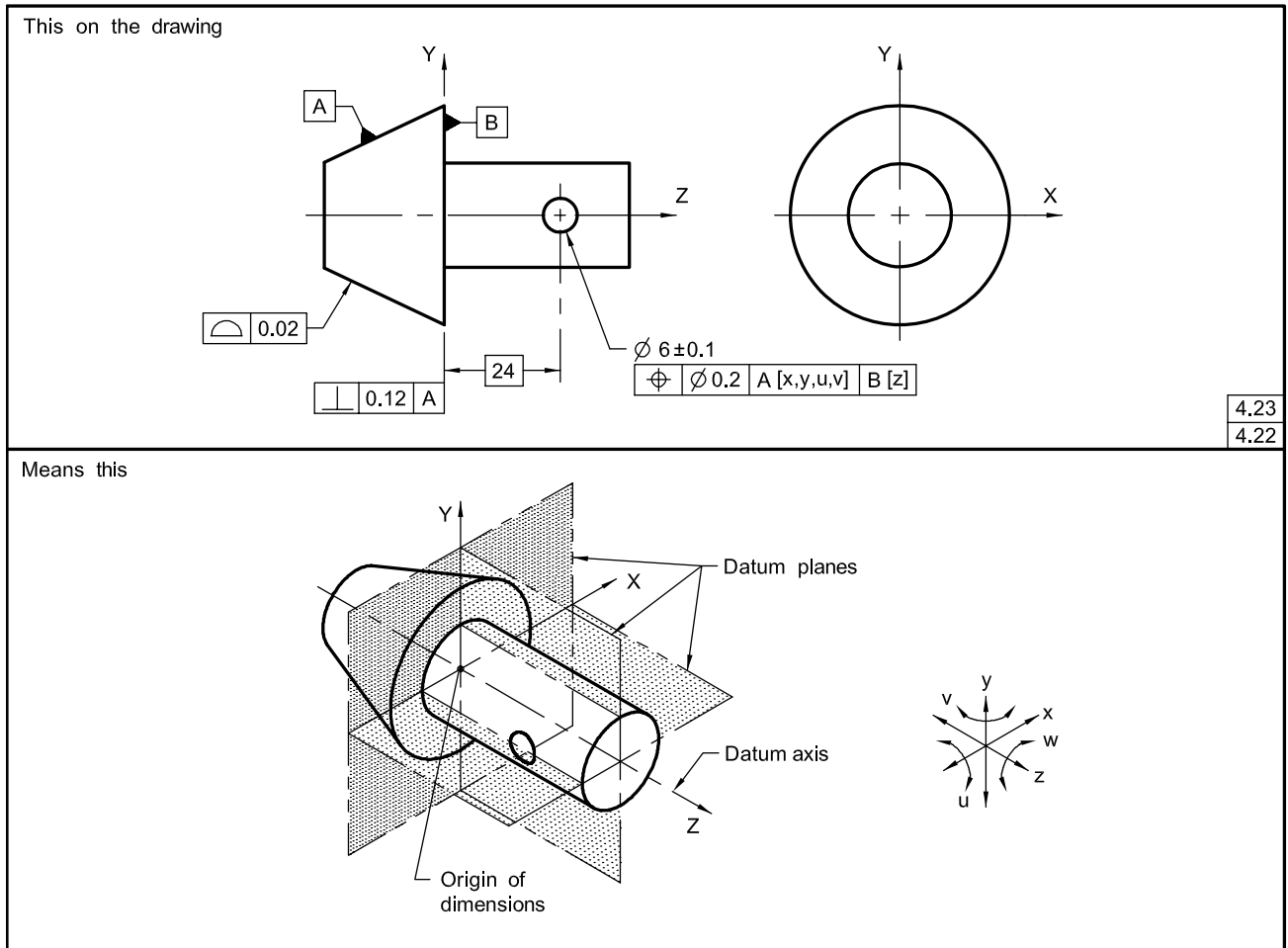


Fig. 4-45 Conical Datum Feature



in Z. The origin of the datum reference frame to locate the 6-diameter hole is from the apex of the conical datum feature simulator. In some applications it may be necessary to customize the datum reference frame. The following are examples of applications of customized datum reference frames:

(a) In Fig. 4-45, the design intent is that the primary datum feature A constrains four degrees of freedom, excluding translation in Z. Secondary datum feature B is a thrust face and when customized constrains the translational degree of freedom (Z). The 6-diameter hole is located to the conical feature with translation Z omitted. Secondary datum feature B constrains translation in Z. In this example, the declared degrees of constraint for datum feature A are X, Y, u, and v. The declared degree of constraint for datum feature B is Z.

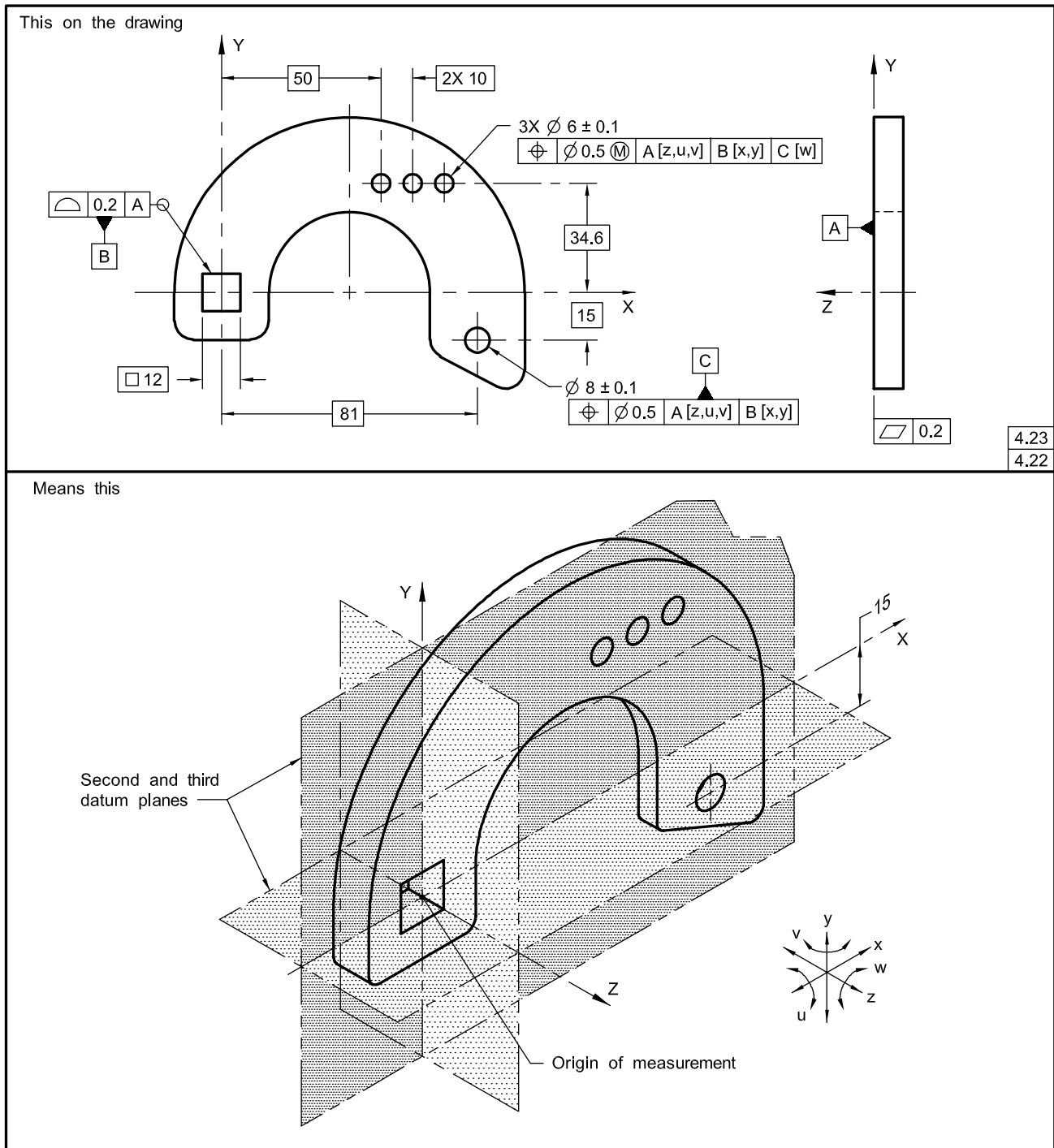
(b) In Fig. 4-46 datum feature B would normally restrain two translational degrees of freedom, X and Y, and one rotational degree of freedom, w. See Fig. 4-3, illustration (f). The purpose of the square hole is to transfer torque but not to orient the part. Therefore, the design intent is that datum feature B restrains two translational

degrees of freedom, but not the rotational degree of freedom. In the position tolerance for the three holes, datum feature A constrains three degrees of freedom, Z, u, and v. Even though datum feature B would normally constrain the three remaining degrees of freedom, using the customized datum reference frame constraint requirements, datum feature B constrains only two translational degrees of freedom, X and Y. Datum feature C, then, constrains the remaining degree of rotational freedom, w.

#### 4.24 DATUM TARGETS

Datum targets are the designated points, lines, or areas that are used in establishing a datum. Datum targets are used in establishing a datum reference frame. Because of inherent irregularities, the entire surface of some features cannot be effectively used to establish a datum. Examples are nonplanar or uneven surfaces produced by casting, forging, or molding; surfaces of weldments; and thin-section surfaces subject to bowing, warping, or other inherent or induced distortions. Datum targets and datum features (as described earlier) may be

Fig. 4-46 Customized Datum Reference Frame



4.23  
4.22

combined to establish a datum reference frame. Where targets are applied to a feature of size, the appropriate material boundary modifier is specified or implied.

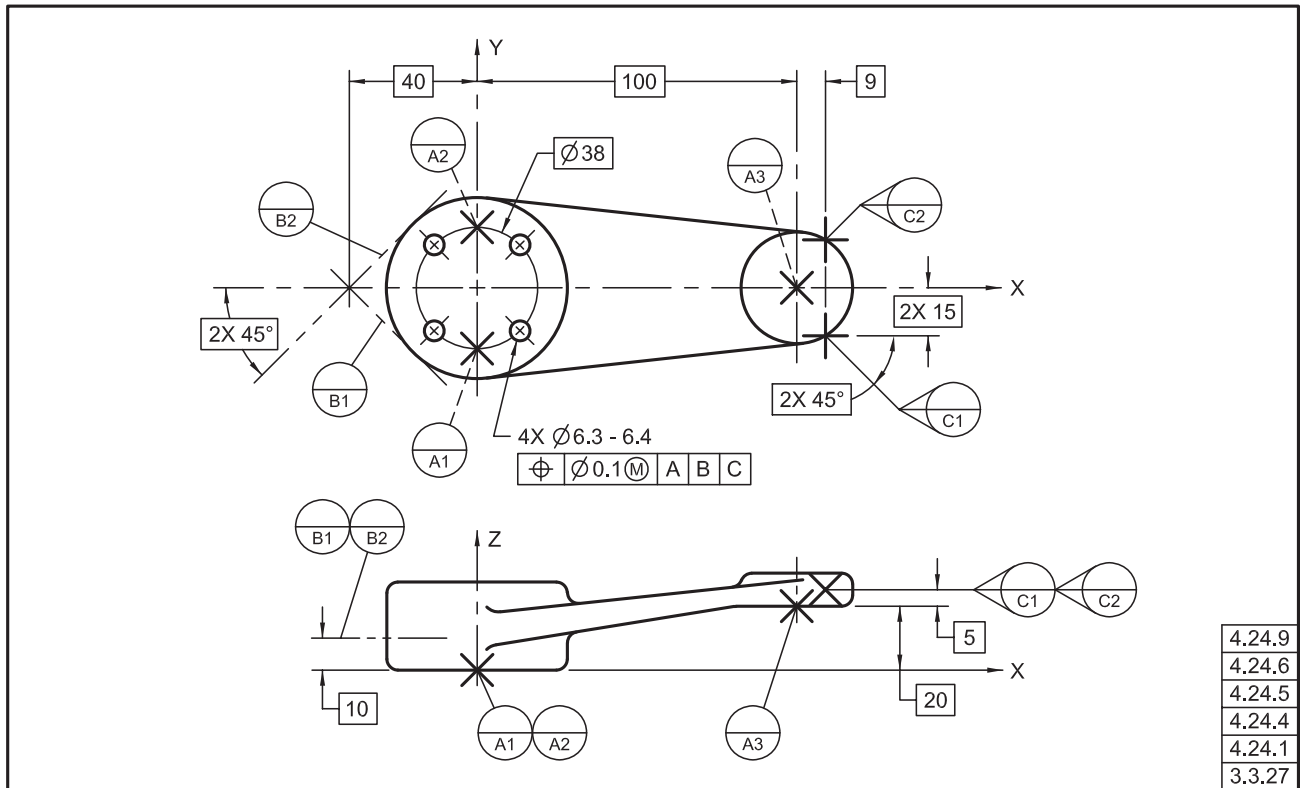
#### 4.24.1 Datum Target Symbols

Datum targets are designated on the drawing by means of a datum target symbol. See Fig. 3-6. The symbol is placed outside the part outline with a radial line

directed to the target. The use of a solid radial line indicates that the datum target symbol is on the near (visible) view of the surface. The use of a dashed radial line, as in Fig. 4-47, indicates that the datum target is on the far (hidden) surface. The datum feature itself may be identified with a datum feature symbol as shown in Fig. 4-53 or by using the datum reference frame symbol as shown in Fig. 4-54.



Fig. 4-47 Applications of Movable Datums



**4.24.2 Datum Target Points**

A datum target point is indicated by the target point symbol, dimensionally located on a direct view of the surface. Where there is no direct view, the point location is dimensioned on two adjacent views. See Figs. 4-48 and 3-7.

**4.24.3 Datum Target Lines**

A datum target line is indicated by the target point symbol on an edge view of the surface, a phantom line on the direct view, or both. See Figs. 4-48 and 3-8. Where the length of the datum target line must be controlled, its length and location are dimensioned.

**4.24.4 Datum Target Areas**

Where it is determined that an area is necessary to assure establishment of the simulated datum (that is, where spherical or pointed pins would be inadequate), a target area of the desired shape is specified. The datum target area is indicated by section lines inside a phantom outline of the desired shape, with controlling dimensions added. The basic size of the area is given in the upper half of the datum target symbol. See Figs. 3-9 and 4-48. Where it becomes impracticable to delineate a target area in the upper half of the datum target symbol, the method of indication shown in Figs. 3-6, 4-42, and 4-47 or basic dimensions may be used to define the shape and size of the datum target area.

**4.24.5 Establishing a Center Plane From Datum Targets**

Figure 4-47 is an example of a V-shaped datum feature simulator established from two datum target lines. In the front view, datum targets B1 and B2 are located relative to datum targets A1 and A2 with a basic dimension and shown as datum target lines. If a tangent plane V-shaped datum feature simulator is required, B1 and B2 would only be shown in the top view.

**4.24.6 Movable Datum Target Symbol**

The movable datum target symbol may be used to indicate movement of the datum target datum feature simulator. Where datum targets establish a center point, axis, or center plane on an RMB basis, the datum feature simulator moves normal to the true profile, and the movable datum target symbol, though not required, may be used for clarity. In other cases where the datum feature simulator is required to move and where the movement is not normal to the true profile, the movable datum target symbol shall be used and the direction of movement shall be clearly defined. See Figs. 4-47 and 4-49.

**4.24.7 Datum Target Dimensions**

The location and size, where applicable, of datum targets are defined with either basic or toleranced dimensions. If defined with basic dimensions, established tooling or gaging tolerances apply. Figure 4-48 illustrates

**Fig. 4-48 Application of Datum Targets to Establish a Datum Reference Frame**

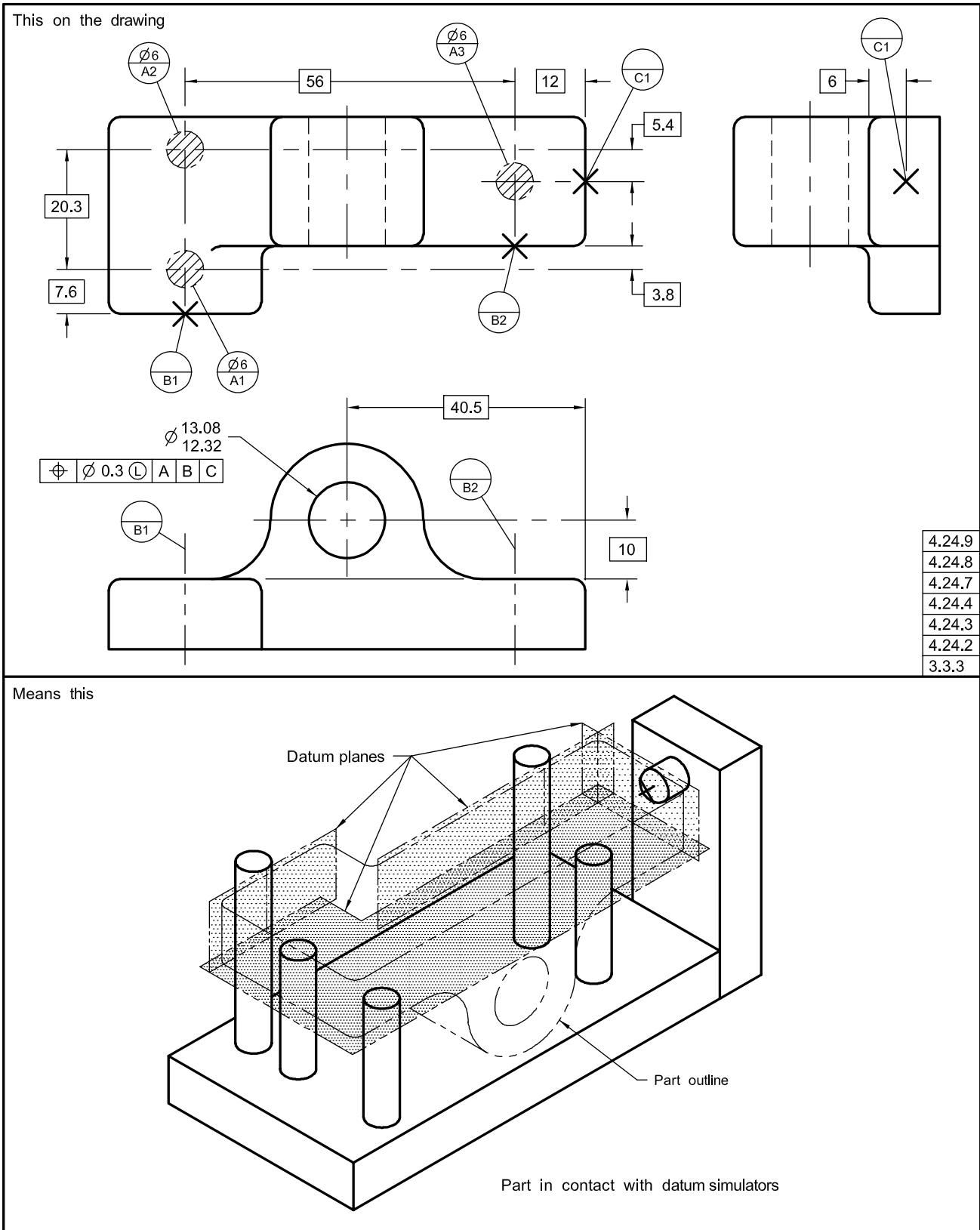
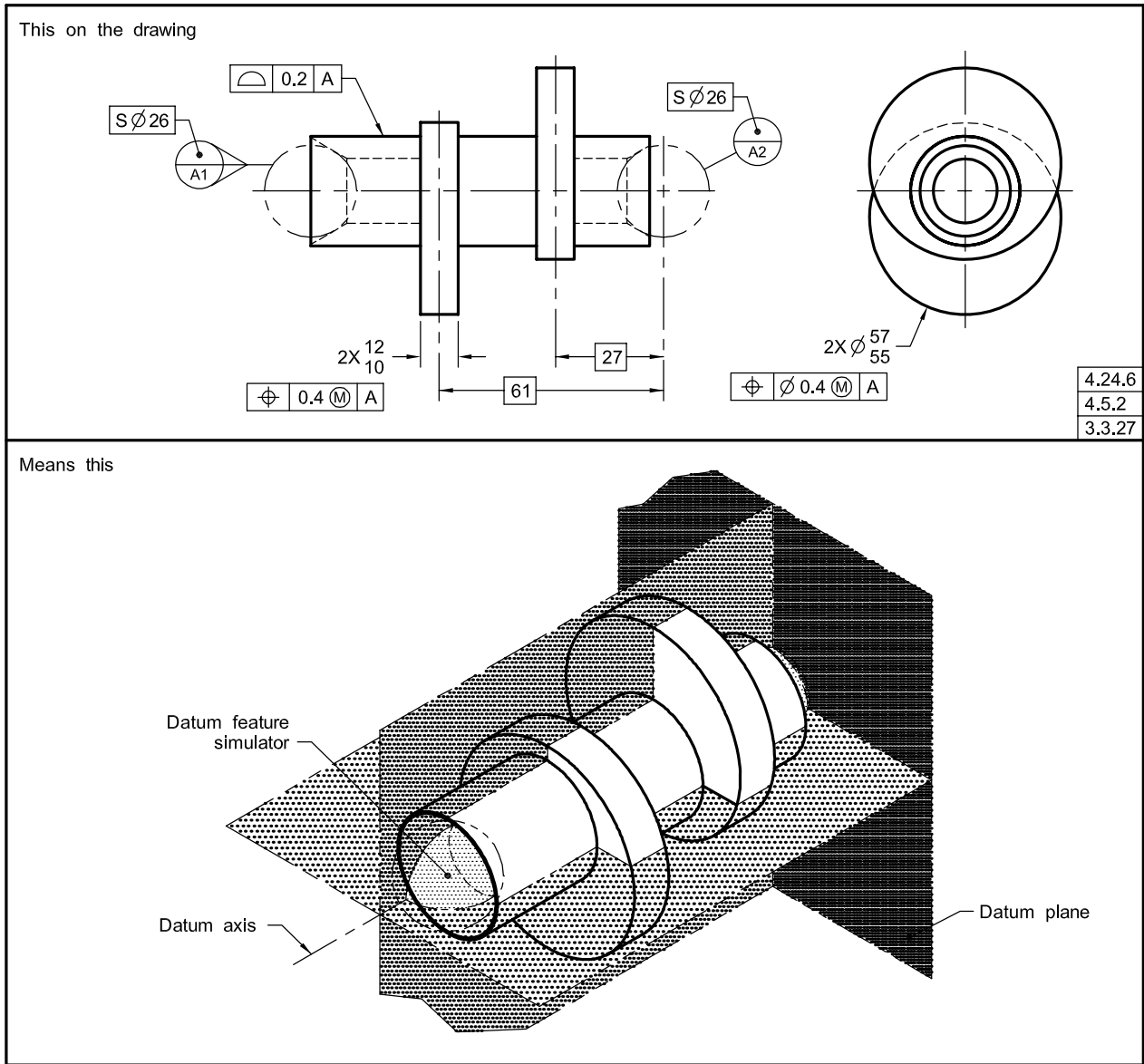


Fig. 4-49 Datum Target Spheres



a part where datum targets are located by means of basic dimensions.

NOTE: For information on datum feature simulator tolerances and toleranced relationships between the simulators, see ASME Y14.43.

**4.24.8 Datum Planes Established by Datum Targets**

A primary datum plane is established by at least three target points not on a straight line. See Fig. 4-48. A secondary datum plane is usually established by two targets. A tertiary datum plane is usually established by one target. A combination of target points, lines, and areas may be used. See Fig. 4-48. For irregular or stepped surfaces, the datum plane should contain at least one of

the datum targets. Some features, such as curved or free-form surfaces, may require datum planes completely offset from the datum targets. See Fig. 4-54.

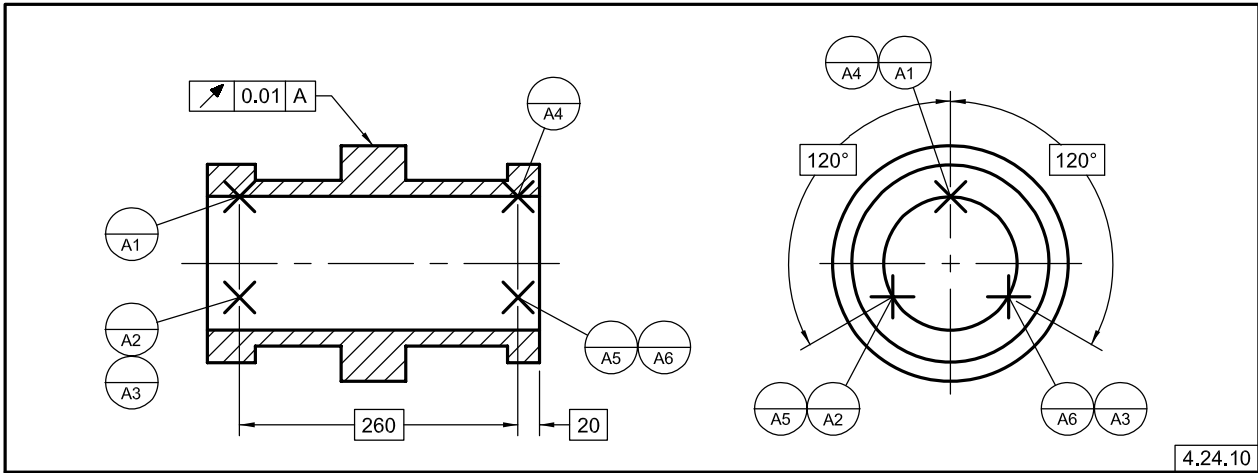
**4.24.9 Stepped Surfaces**

A datum plane may also be established by targets located on stepped surfaces, as in Figs. 4-47 and 4-48. The basic dimension defines the offset between the target points.

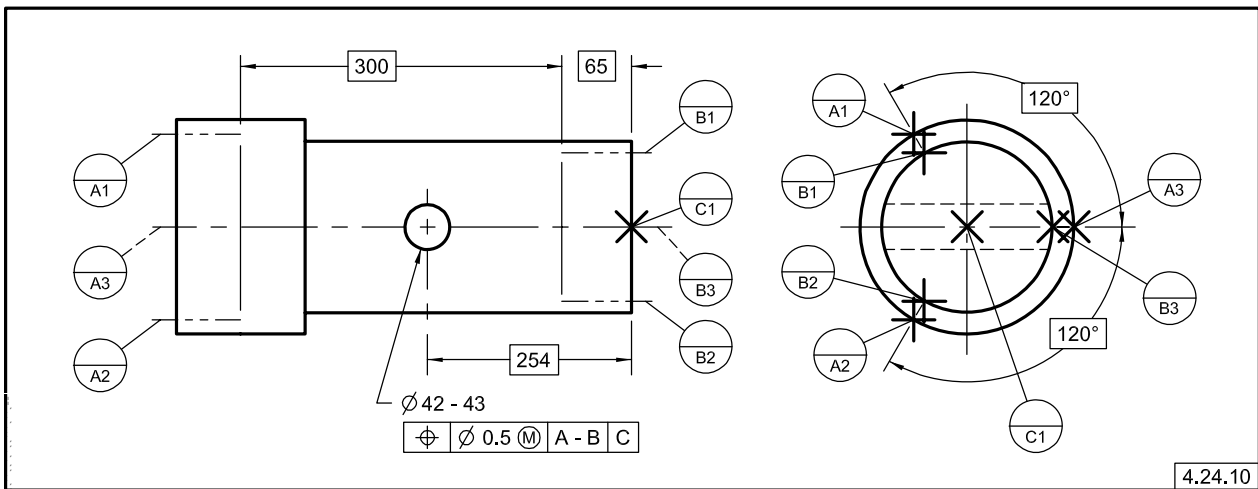
**4.24.10 Primary Datum Axis**

Two sets of three equally spaced datum targets may be used to establish a datum axis for a primary datum feature. See Figs. 4-50 and 4-51. The two datum target sets are spaced as far apart as practical and dimensioned

**Fig. 4-50 Primary Datum Axis Established by Datum Target Points on a Single Cylindrical Feature**



**Fig. 4-51 Primary and Secondary Datum Established by Datum Target Lines on Two Cylindrical Features and a Surface**



from the secondary datum feature. At RMB, a centering procedure used to establish the datum axis has two sets of three equally spaced contacting datum target simulators capable of moving radially at an equal rate from a common axis. To ensure repeatability of the location of the three datum target points, a tertiary datum feature may be necessary. For MMB, the centering procedure used to establish the datum axis has two sets of three equally spaced datum target simulators set at a fixed radial distance based on the maximum material boundary. Where two cylindrical datum features are used to establish a datum axis, as in Fig. 4-51, each datum feature is identified with a different letter.

**4.24.11 Circular and Cylindrical Targets**

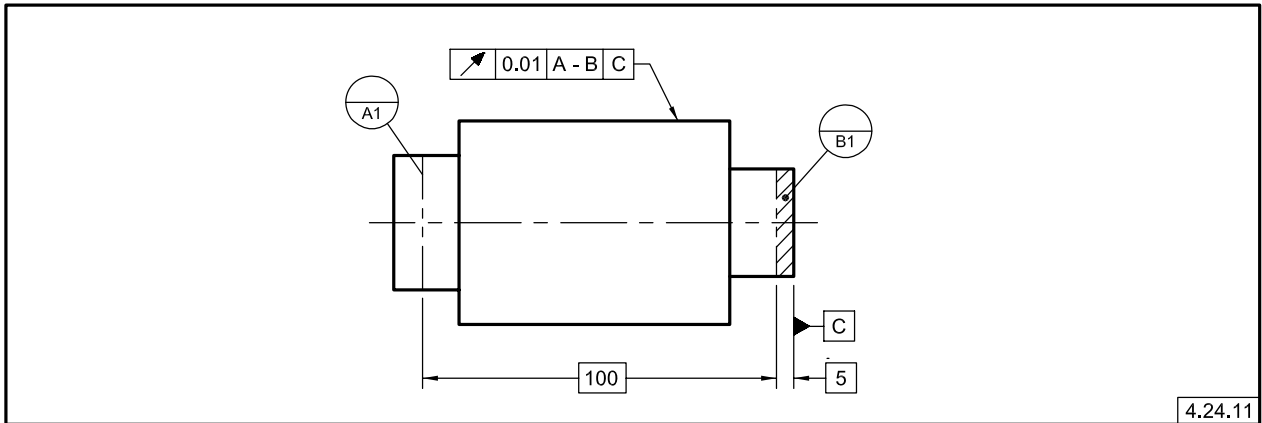
Circular target lines and cylindrical target areas may be used to establish a datum axis on round features.

See Fig. 4-52. When a datum target area or datum target line is shown on a non-planar surface, the shape of the datum target line simulator is the same as the shape of the surface. In Fig. 4-42, the datum target area simulators for A1 through A5 are the same as the contour of the part surface.

**4.24.12 Secondary Datum Axis**

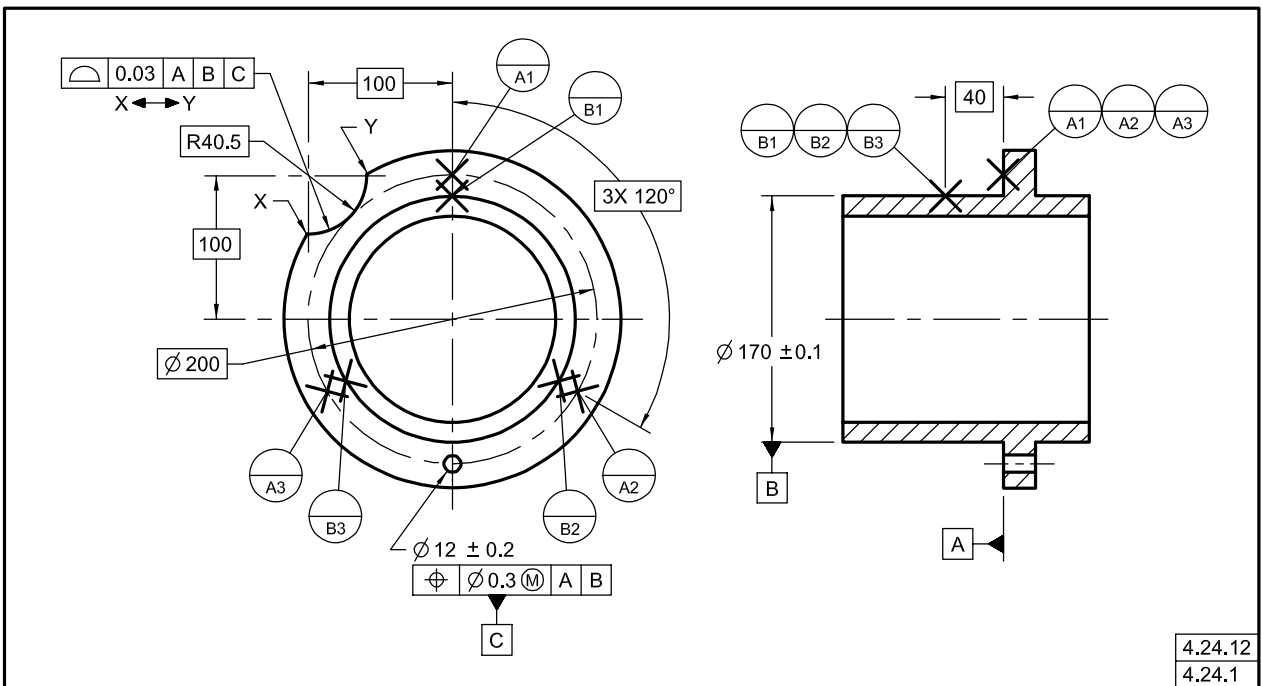
For a secondary datum feature, a set of three equally spaced targets may be used to establish a datum axis. See Fig. 4-53. In this example, the datum targets and the contacting datum feature simulators are oriented relative to the datum reference frame. At RMB, a typical centering method used to establish the datum axis has a set of three equally spaced contacting datum feature simulators capable of moving radially at an equal rate from a common axis that is perpendicular to the primary datum

Fig. 4-52 Datum Target Line and Areas



4.24.11

Fig. 4-53 Secondary Datum Axis



4.24.12

4.24.1

plane. For MMB, the centering method used to establish the datum axis has a set of three equally spaced features set at a fixed radial distance based on the MMB.

**4.24.13 Datums Established From Complex or Irregular Surfaces**

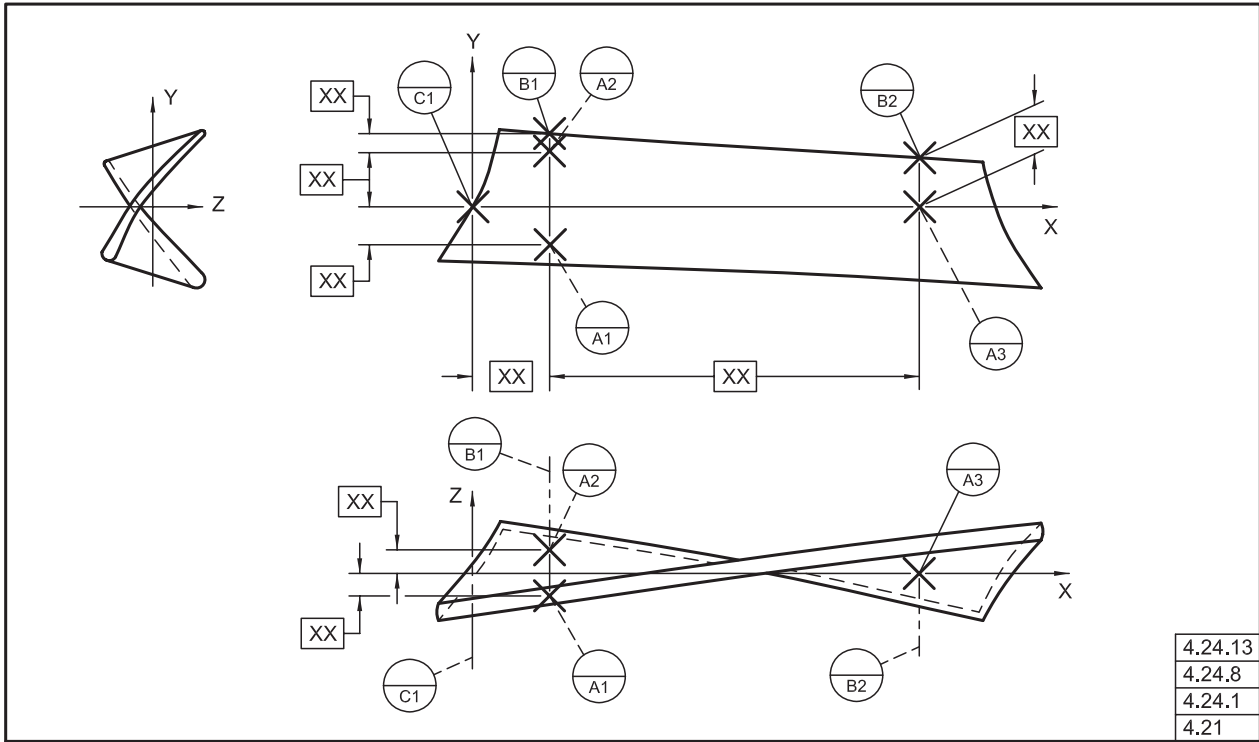
Datum targets may be used to establish a datum from a complex or irregular surface. Where a datum reference frame has been properly established but its planes are unclear, the datum reference frame coordinate axes may be labeled to appropriate extension or center lines as needed. See Fig. 4-54. The datum feature symbol should

be attached only to identifiable datum features. Where datums are established by targets on complex or irregular surfaces, the datum may be identified by a note such as DATUM AXIS A or DATUM PLANE A.

**4.24.14 Datum Features Established From Datum Targets With Fewer Than Three Mutually Perpendicular Planes**

When using datum features that are defined by datum targets in a feature control frame established by fewer than three mutually perpendicular planes, the datums that are the basis for the feature control frame shall be

**Fig. 4-54 Datum Targets Used to Establish Datum Reference Frame for Complex Part**



referenced. The targets that provide definition for the datums referenced in the feature control frame shall be specified in a note, such as,

**DATUM FEATURES B AND C ARE INVOKED WHERE ONLY DATUM FEATURE A IS REFERENCED TO RELATE THE TARGETS THAT ESTABLISH DATUM A**

## Section 5

# Tolerances of Form

### 5.1 GENERAL

This Section establishes the principles and methods of dimensioning and tolerancing to control the form of features.

### 5.2 FORM CONTROL

Form tolerances control straightness, flatness, circularity, and cylindricity. When specifying a form tolerance, consideration must be given to the control of form already established through other tolerances such as size (Rule #1), orientation, runout, and profile controls. See para. 2.7 and Fig. 2-6.

### 5.3 SPECIFYING FORM TOLERANCES

Form tolerances critical to function and interchangeability are specified where the tolerances of size do not provide sufficient control. A tolerance of form may be specified where no tolerance of size is given (e.g., in the control of flatness after assembly of the parts). A form tolerance specifies a zone within which the considered feature, its line elements, its derived median line, or its derived median plane must be contained.

### 5.4 FORM TOLERANCES

Form tolerances are applicable to single (individual) features, elements of single features, or features of size; therefore, form tolerances are not related to datums. The following subparagraphs cover the particulars of the form tolerances: straightness, flatness, circularity, and cylindricity.

#### 5.4.1 Straightness

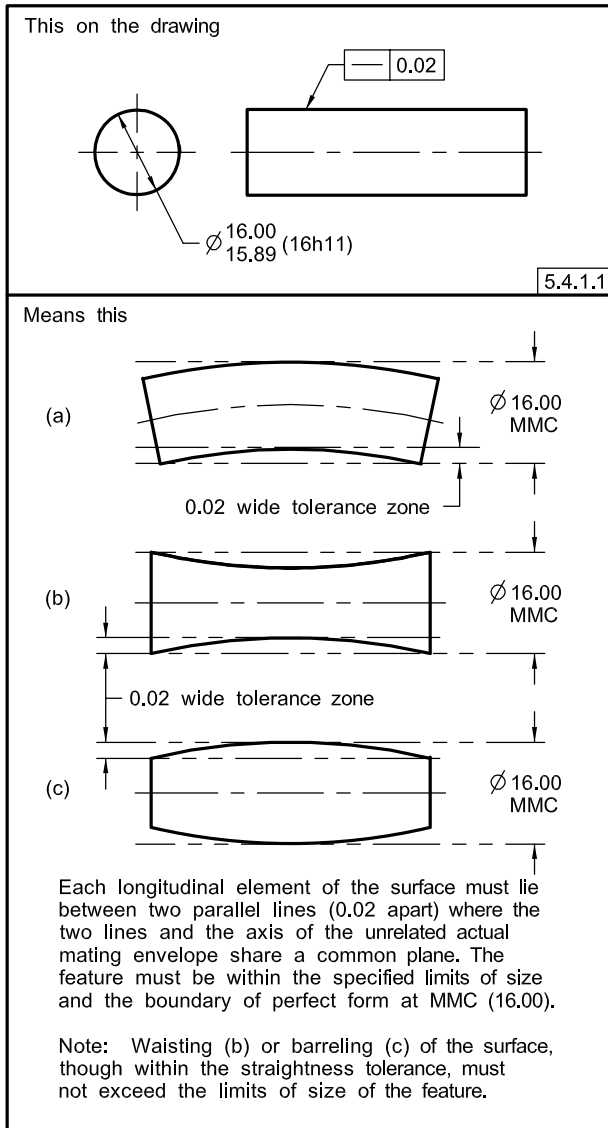
Straightness is a condition where an element of a surface, or derived median line, is a straight line. A straightness tolerance specifies a tolerance zone within which the considered element of a surface or derived median line must lie. A straightness tolerance is applied in the view where the elements to be controlled are represented by a straight line.

**5.4.1.1 Cylindrical Features.** Figure 5-1 shows an example of a cylindrical feature where all circular elements of the surface are to be within the specified size tolerance. Each longitudinal element of the surface must

lie between two parallel lines separated by the amount of the prescribed straightness tolerance and in a plane common with the axis of the unrelated actual mating envelope of the feature. The feature control frame is attached to a leader directed to the surface or extension line of the surface but not to the size dimension. The straightness tolerance must be less than the size tolerance and any other geometric tolerances that affect the straightness of line elements. Since the limits of size must be respected, the full straightness tolerance may not be available for opposite elements in the case of waisting or barreling of the surface. See Fig. 5-1. When the independency symbol is applied to the size dimension, the requirement for perfect form at MMC is removed and the form tolerance may be larger than the size tolerance.

**5.4.1.2 Violation of MMC Boundary.** Figures 5-2 and 5-3 show examples of cylindrical features where all circular elements of the surface are to be within the specified size tolerance; however, the boundary of perfect form at MMC may be violated. This violation is permissible when the feature control frame is associated with the size dimension or attached to an extension of the dimension line. In this instance, a diameter symbol precedes the tolerance value, and the tolerance is applied on either an RFS or MMC basis. Where necessary and when not used in conjunction with an orientation or position tolerance, the straightness tolerance may be greater than the size tolerance. Where the straightness tolerance is used in conjunction with an orientation tolerance or position tolerance value, the specified straightness tolerance value shall not be greater than the specified orientation or position tolerance value. The collective effect of size and form variation can produce a virtual condition or outer or inner boundary equal to the MMC size plus the straightness tolerance. When applied on an RFS basis, as in Fig. 5-2, the maximum straightness tolerance is the specified tolerance. When applied on an MMC basis, as in Fig. 5-3, the maximum straightness tolerance is the specified tolerance plus the amount the actual local size as the feature departs from its MMC size. The derived median line of an actual feature at MMC must lie within a cylindrical tolerance zone as specified. As each actual local size departs from MMC, an increase in the local diameter of the tolerance zone that is equal to the amount of such departure is allowed. Each circular element of the surface (that is, actual local size) must be within the specified limits of size.

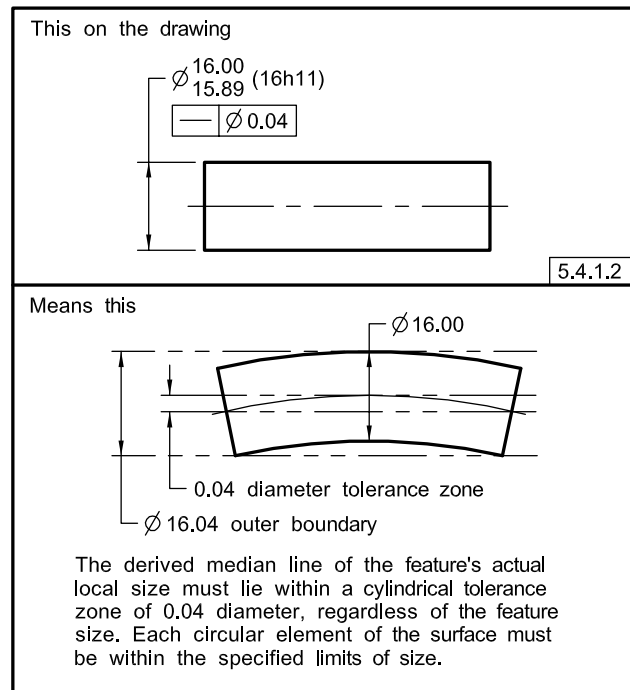
**Fig. 5-1 Specifying Straightness of Surface Elements**



**5.4.1.3 Applied on a Unit Basis.** Straightness may be applied on a unit basis as a means of limiting an abrupt surface variation within a relatively short length of the feature. See Fig. 5-4. When using unit control on a feature of size, a maximum limit is typically specified to limit the relatively large theoretical variations that may result if left unrestricted. If the unit variation appears as a “bow” in the toleranced feature, and the “bow” is allowed to continue at the same rate for several units, the overall tolerance variation may result in an unsatisfactory part. Figure 5-5 illustrates the possible condition where straightness per unit length given in Fig. 5-4 is used alone (i.e., if straightness for the total length is not specified).

**5.4.1.4 Straightness of Line Elements.** Figure 5-6 illustrates the use of straightness tolerance on a flat surface. Straightness may be applied to control line elements

**Fig. 5-2 Specifying Straightness RFS**



in a single direction on a flat surface; it may also be applied in two directions as shown. Where function requires the line elements to be related to a datum feature(s), profile of a line should be specified related to datums. See Fig. 8-27.

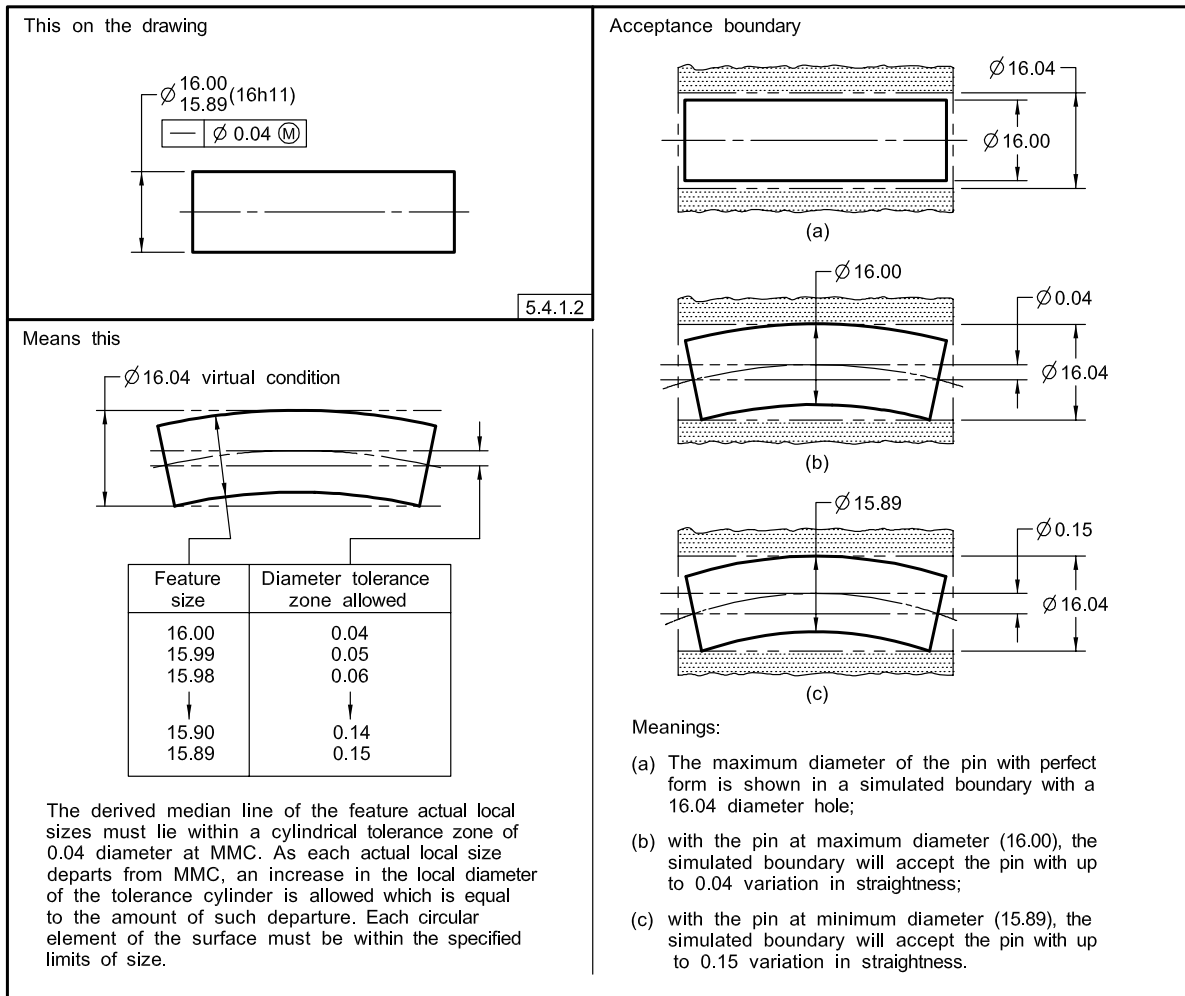
**5.4.2 Flatness**

Flatness is the condition of a surface or derived median plane having all elements in one plane. A flatness tolerance specifies a tolerance zone defined by two parallel planes within which the surface or derived median plane must lie. When a flatness tolerance is specified on a surface, the feature control frame is attached to a leader directed to the surface or to an extension line of the surface. It is placed in a view where the surface elements to be controlled are represented by a line. See Fig. 5-7. With flatness of a surface, where the considered surface is associated with a size dimension, the flatness tolerance must be less than the size tolerance. When the independency symbol is applied to the size dimension, the requirement for perfect form at MMC is removed and the form tolerance may be larger than the size tolerance.

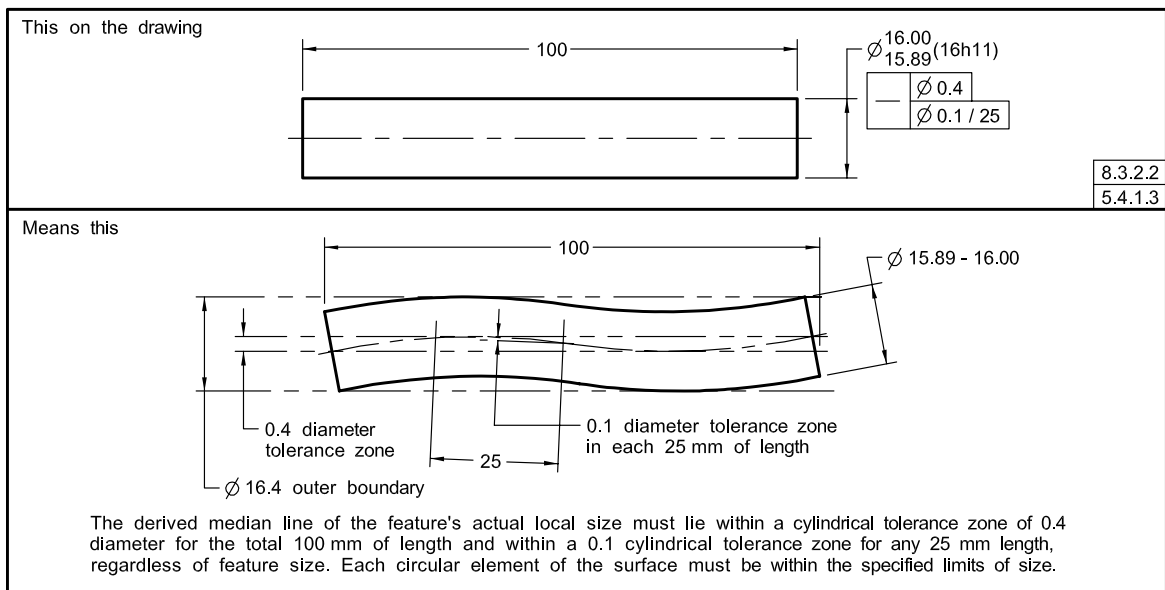
**5.4.2.1 Application of Flatness RFS, MMC, or LMC to Noncylindrical Features.** As an extension of the principles of para. 5.4.1.2, flatness may be applied on an RFS, MMC, or LMC basis to noncylindrical features of size. In this instance, the derived median plane must lie in a tolerance zone between two parallel planes separated by the amount of the tolerance. Feature control frame



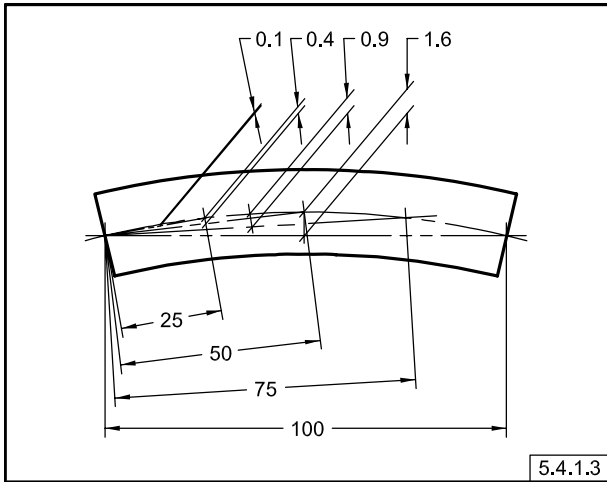
**Fig. 5-3 Specifying Straightness at MMC**



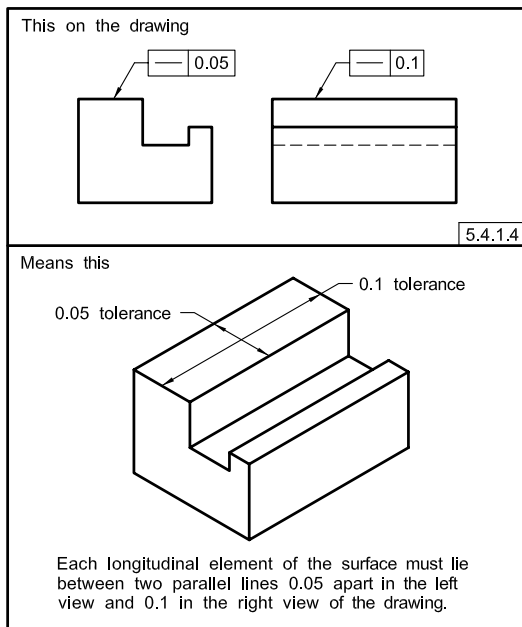
**Fig. 5-4 Specifying Straightness Per Unit Length With Specified Total Straightness, Both RFS**



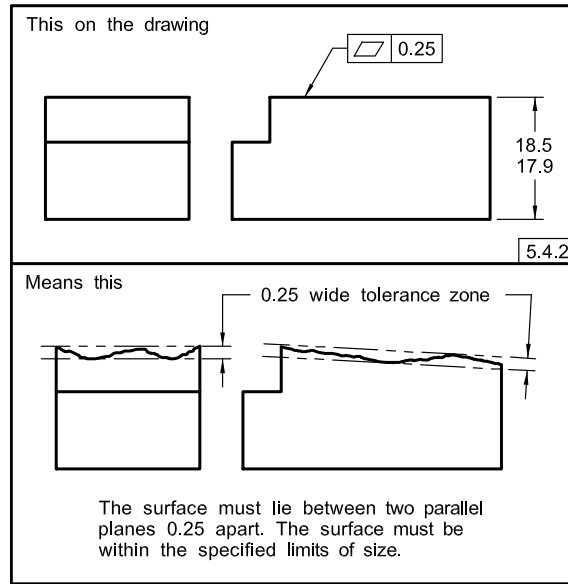
**Fig. 5-5 Possible Results of Specifying Straightness Per Unit Length RFS, With No Specified Total**



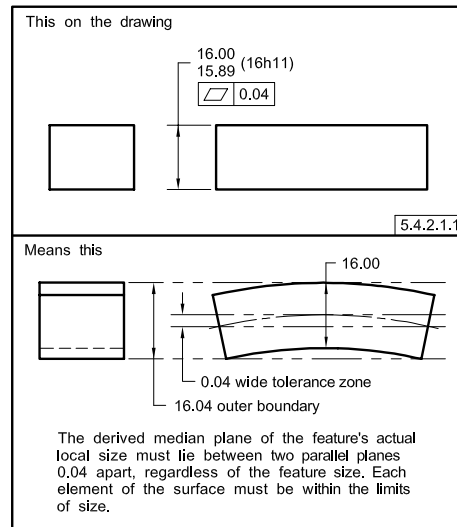
**Fig. 5-6 Specifying Straightness of a Flat Surface**



**Fig. 5-7 Specifying Flatness of a Surface**



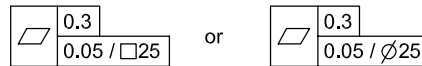
**Fig. 5-8 Specifying Flatness of a Derived Median Plane – RFS**



placement and arrangement as described in para. 5.4.1.2 apply, except the diameter symbol is not used, since the tolerance zone is noncylindrical. See Figs. 5-8 and 5-9.

**5.4.2.2 Applied on Unit Basis.** Flatness may be applied on a unit basis as a means of limiting an abrupt surface variation within a relatively small area of the feature. The unit variation is used either in combination with a specified total variation, or alone. Caution should be exercised when using unit control alone for the reasons given in para. 5.4.1.3. Since flatness involves surface area, the size of the unit area (e.g., a square area  $25 \times 25$  or a circular area 25 in diameter) is specified to

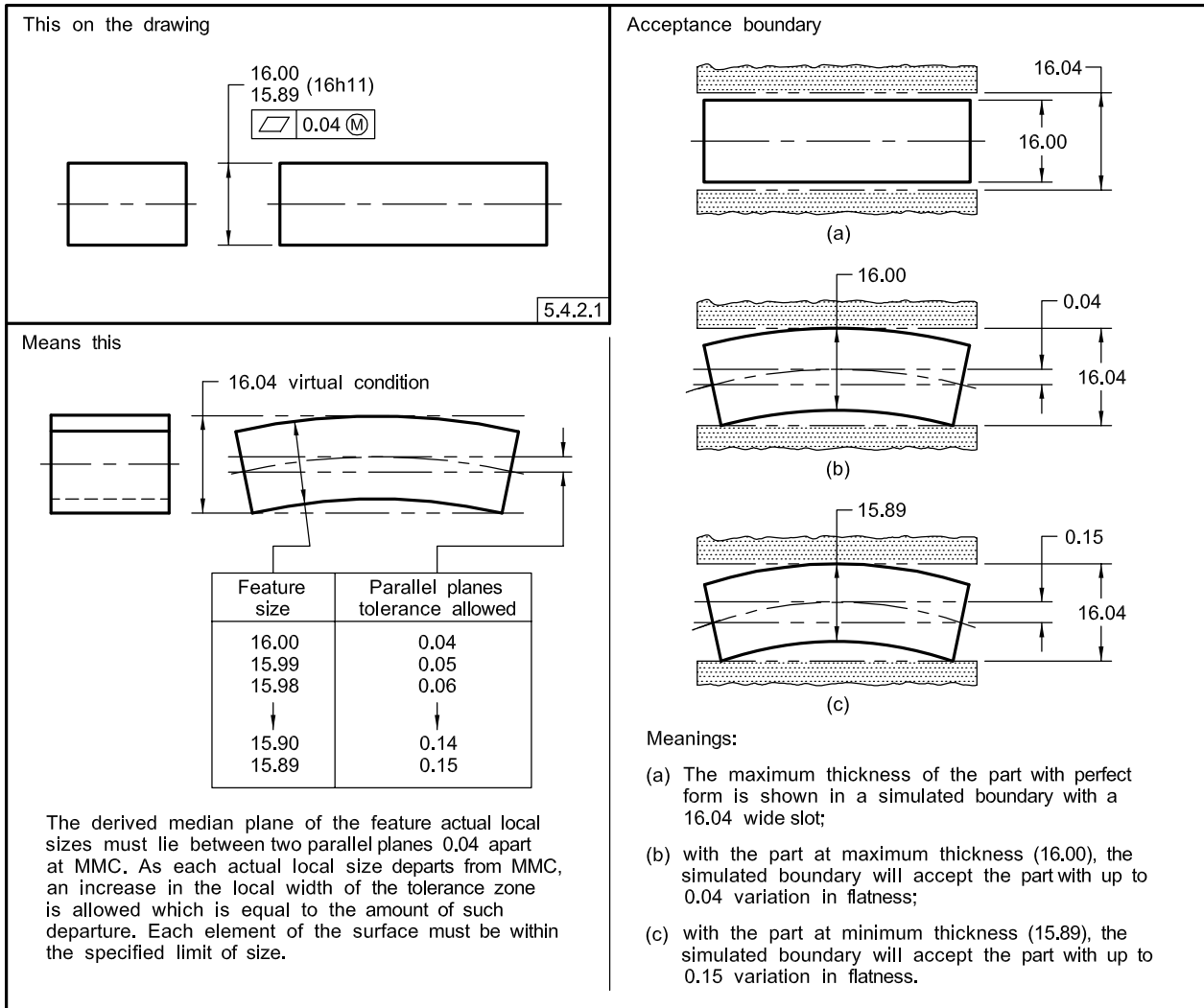
the right of the flatness tolerance, separated by a slash. For example,



**5.4.3 Circularity (Roundness)**

Circularity is a condition of a surface where (a) for a feature other than a sphere, all points of the surface intersected by any plane perpendicular to an axis or spine (curved line) are equidistant from that axis or spine

**Fig. 5-9 Specifying Flatness of a Derived Median Plane at MMC**



(b) for a sphere, all points of the surface intersected by any plane passing through a common center are equidistant from that center

A circularity tolerance specifies a tolerance zone bounded by two concentric circles within which each circular element of the surface must lie, and applies independently at any plane described in subparas. (a) and (b) above. See Figs. 5-10 and 5-11. The circularity tolerance must be less than the size tolerance and other geometric tolerances that affect the circularity of the feature, except for those parts subject to free-state variation or the independency principle. See para. 5.5.

NOTE: See ANSI B89.3.1 and ASME Y14.5.1M for further information on this subject.

#### 5.4.4 Cylindricity

Cylindricity is a condition of a surface of revolution in which all points of the surface are equidistant from a

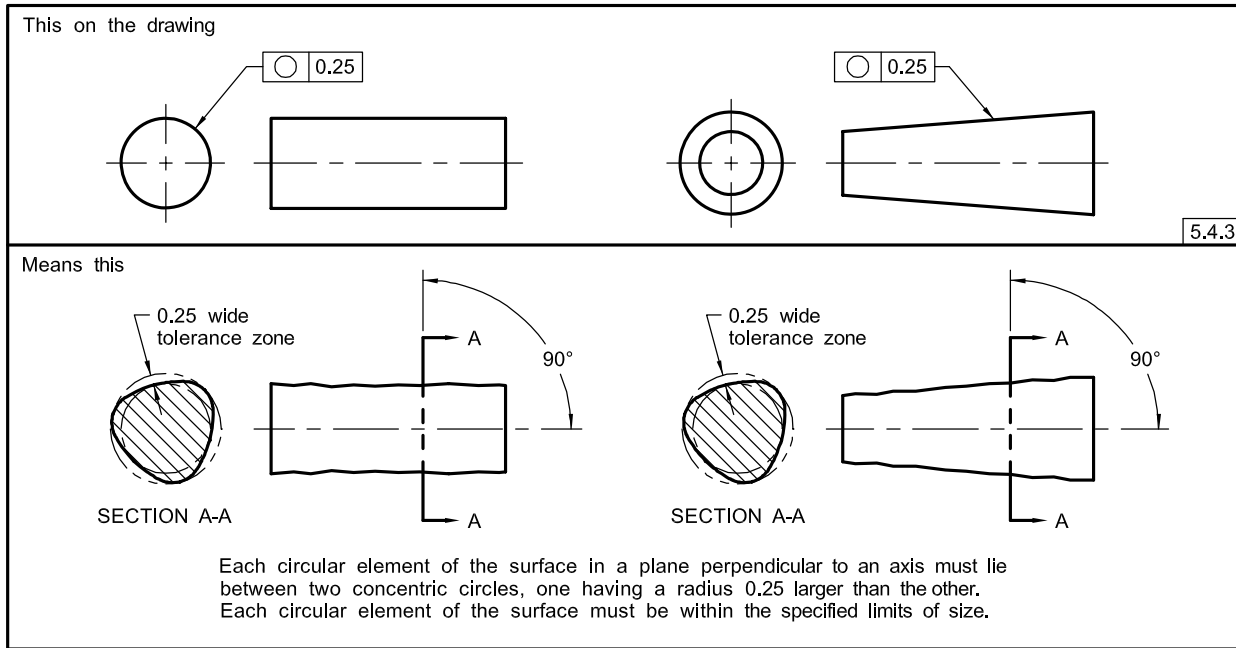
common axis. A cylindricity tolerance specifies a tolerance zone bounded by two concentric cylinders within which the surface must lie. In the case of cylindricity, unlike that of circularity, the tolerance applies simultaneously to both circular and longitudinal elements of the surface (the entire surface). See Fig. 5-12. The leader from the feature control frame may be directed to either view. The cylindricity tolerance must be less than the size tolerance except parts subject to free-state variation or the independency principle.

NOTE: The cylindricity tolerance is a composite control of form that includes circularity, straightness, and taper of a cylindrical feature.

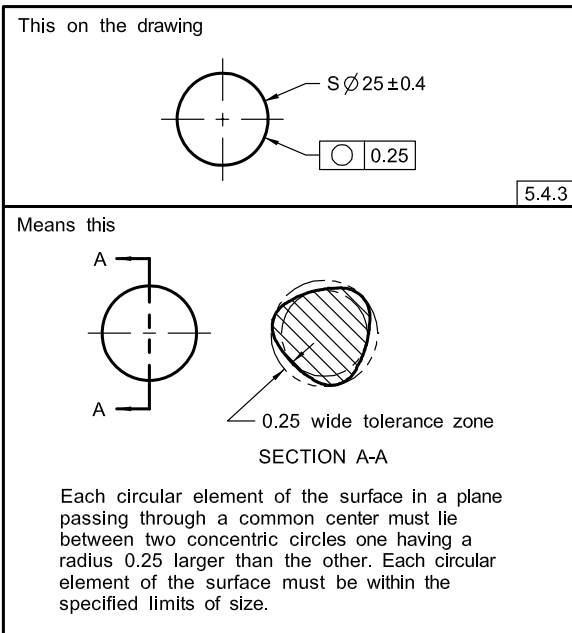
#### 5.5 APPLICATION OF FREE-STATE SYMBOL

Free-state variation is the distortion of a part after removal of forces applied during manufacture. This distortion is principally due to weight and flexibility of the

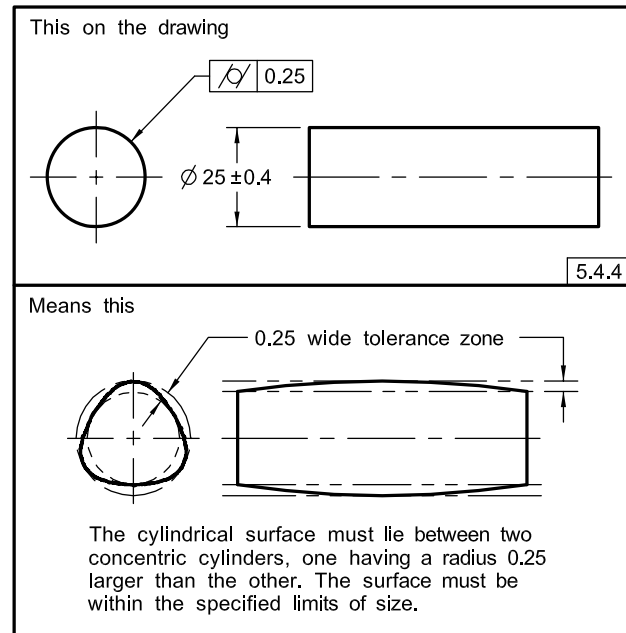
**Fig. 5-10 Specifying Circularity for a Cylinder or Cone**



**Fig. 5-11 Specifying Circularity of a Sphere**



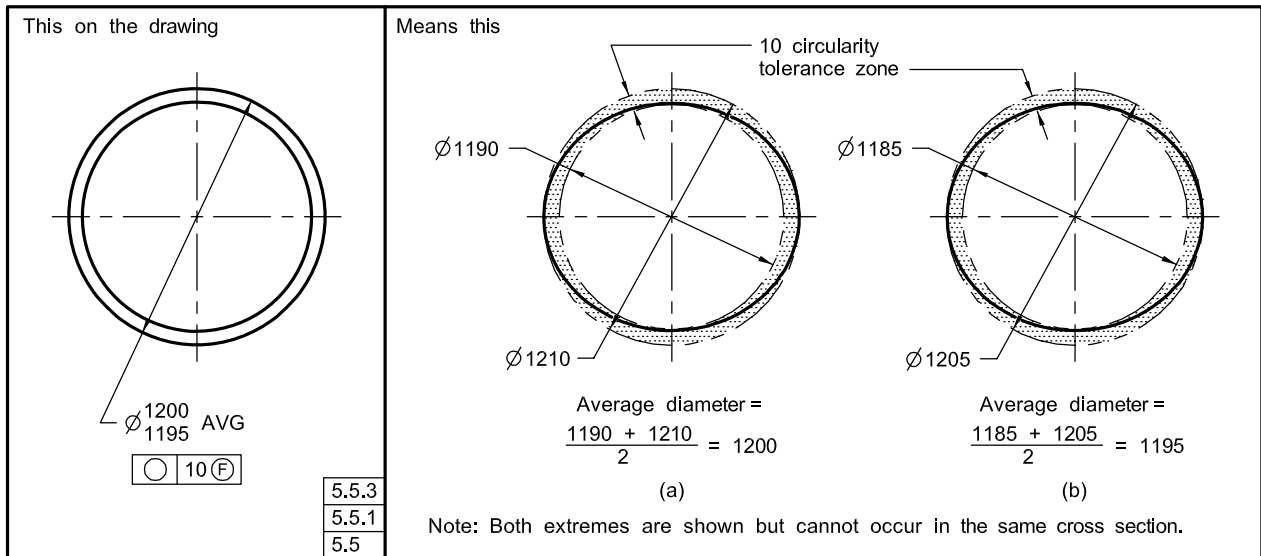
**Fig. 5-12 Specifying Cylindricity**



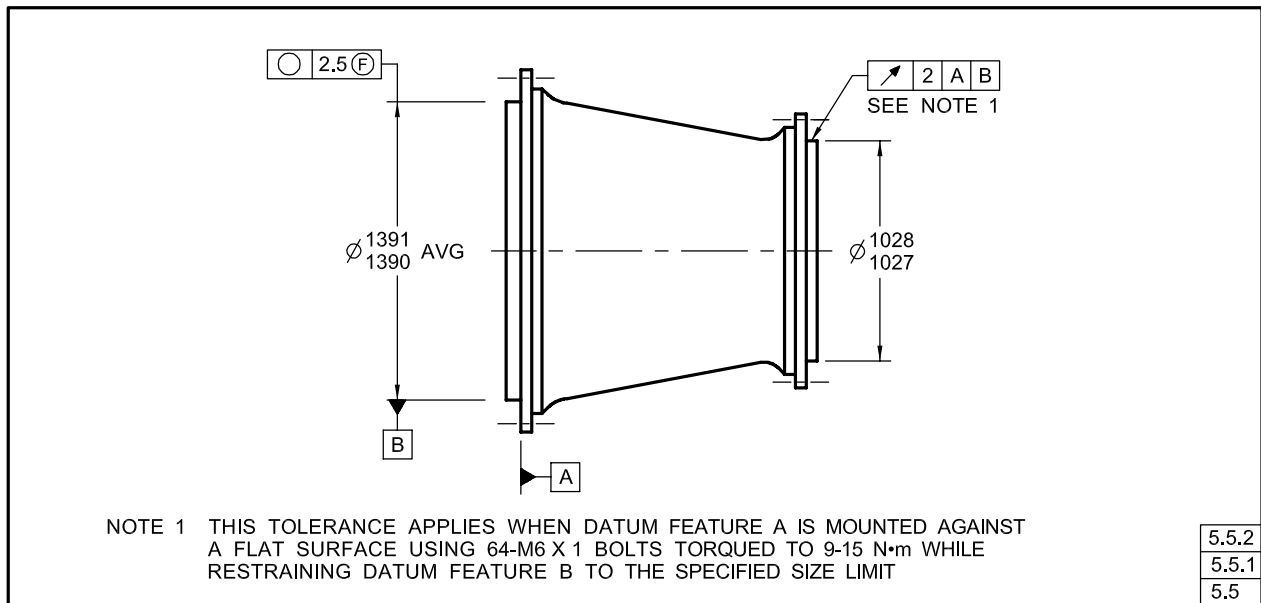
part and the release of internal stresses resulting from fabrication. A part of this kind (e.g., a part with a very thin wall in proportion to its diameter) is referred to as a nonrigid part. In some cases, it may be required that the part meet its tolerance requirements while in the free state. See Fig. 5-13. In others, it may be necessary to simulate the mating part interface to verify individual or related feature tolerances. This is done by restraining

the appropriate features, such as the datum features in Fig. 5-14. The restraining forces are those that would be exerted in the assembly or functioning of the part. However, if the dimensions and tolerances are met in the free state, it is usually not necessary to restrain the part unless the effect of subsequent restraining forces on the concerned features could cause other features of the part to exceed specified limits. Free-state variation

**Fig. 5-13 Specifying Circularity in a Free State With Average Diameter**



**Fig. 5-14 Specifying Restraint for Nonrigid Parts**



of nonrigid parts may be controlled as described in paras. 5.5.1 through 5.5.3.

**5.5.1 Specifying Geometric Tolerances on Features Subject to Free-State Variation**

Where an individual form or location tolerance is applied to a feature in the free state, specify the maximum allowable free-state variation with an appropriate feature control frame. See Fig. 5-13. The free-state symbol may be placed within the feature control frame, following the tolerance and any modifiers, to clarify a free-state requirement on a drawing containing restrained feature

notes, or to separate a free-state requirement from associated features having restrained requirements. See Figs. 3-21 and 5-14.

**5.5.2 Specifying Geometric Tolerances on Features to Be Restrained**

Where geometric tolerances are to be verified with the part in a restrained condition, select and identify the features (pilot diameter, bosses, flanges, etc.) to be used as datum features, as applicable. There may be some cases where form or profile tolerances may be restrained. Since these surfaces may be subject to free-state variation, it

is necessary to specify the maximum force necessary to restrain each of them. Determine the amount of the restraining or holding forces and other requirements necessary to simulate expected assembly conditions. Specify on the drawing that if restrained to this condition, the remainder of the part or certain features thereof shall be within stated tolerances. See Fig. 5-14.

### 5.5.3 Average Diameter

An average diameter is the average of several diametric measurements across a circular or cylindrical feature. Normally, enough (at least four) measurements are taken to ensure the establishment of an average diameter. If practical, an average diameter may be determined by a peripheral tape measurement. Where form control,

such as circularity, is specified in a free state for a circular or cylindrical feature, the pertinent diameter is qualified with the abbreviation **AVG**. See Fig. 5-13. Specifying circularity on the basis of an average diameter on a non-rigid part is necessary to ensure that the actual diameter of the feature can be restrained to the desired shape at assembly. Note that the free-state circularity tolerance is greater than the size tolerance on the diameter. Figure 5-13, illustrations (a) and (b), simplified by showing only two measurements, give the permissible diameters in the free state for two extreme conditions of maximum average diameter and minimum average diameter, respectively. The same method applies when the average diameter is anywhere between maximum and minimum limits.

## Section 6

# Tolerances of Orientation

### 6.1 GENERAL

This Section establishes the principles and methods of dimensioning and tolerancing to control orientation of features.

### 6.2 ORIENTATION CONTROL

An orientation tolerance controls parallel, perpendicular, and all other angular relationships. Note that an orientation tolerance, when applied to a plane surface, controls flatness to the extent of the orientation tolerance. When the flatness control in the orientation tolerance is not sufficient, a separate flatness tolerance should be considered. An orientation tolerance does not control the location of features. When specifying an orientation tolerance, consideration must be given to the control of orientation already established through other tolerances such as location, runout, and profile controls. See Fig. 7-8.

### 6.3 ORIENTATION SYMBOLS

There are three orientation relationships and three symbols to define those relationships. The three orientation relationships are noted in paras. 6.3.1 through 6.3.3.

#### 6.3.1 Angularity

Angularity is the condition of a surface, feature's center plane, or feature's axis at any specified angle from a datum plane or datum axis. See Fig. 3-1.

#### 6.3.2 Parallelism

Parallelism is the condition of a surface or feature's center plane, equidistant at all points from a datum plane; or a feature's axis, equidistant along its length from one or more datum planes or datum axis. See Fig. 3-1.

#### 6.3.3 Perpendicularity

Perpendicularity is the condition of a surface, feature's center plane, or feature's axis at a right angle to a datum plane or datum axis. See Fig. 3-1.

### 6.4 SPECIFYING ORIENTATION TOLERANCES

When specifying an orientation tolerance, the considered feature shall be related to one or more datums. See Figs. 4-4 and 6-4. Orientation tolerances are constrained

only in rotational degrees of freedom relative to the referenced datums; they are not constrained in the translational degrees of freedom. Thus, with orientation tolerances, even in those instances where datum features may constrain all degrees of freedom, the tolerance zone only orients to that datum reference frame. Sufficient datum features should be referenced to constrain the required rotational degrees of freedom. If the primary datum feature alone does not constrain sufficient degrees of freedom, additional datum features may be specified.

#### 6.4.1 Orientation Tolerance Zone

An orientation tolerance specifies a zone within which the considered feature, its line elements, its axis, or its center plane must be contained.

#### 6.4.2 Orientation Tolerance

An orientation tolerance specifies one of the following:

(a) a tolerance zone defined by two parallel planes at the specified basic angle from, parallel to, or perpendicular to one or more datum planes or a datum axis, within which the surface or center plane of the considered feature must lie. See Figs. 6-1 through 6-5.

(b) a tolerance zone defined by two parallel planes at the specified basic angle from, parallel to, or perpendicular to one or more datum planes or a datum axis, within which the axis of the considered feature must lie. See Figs. 6-6 and 6-7.

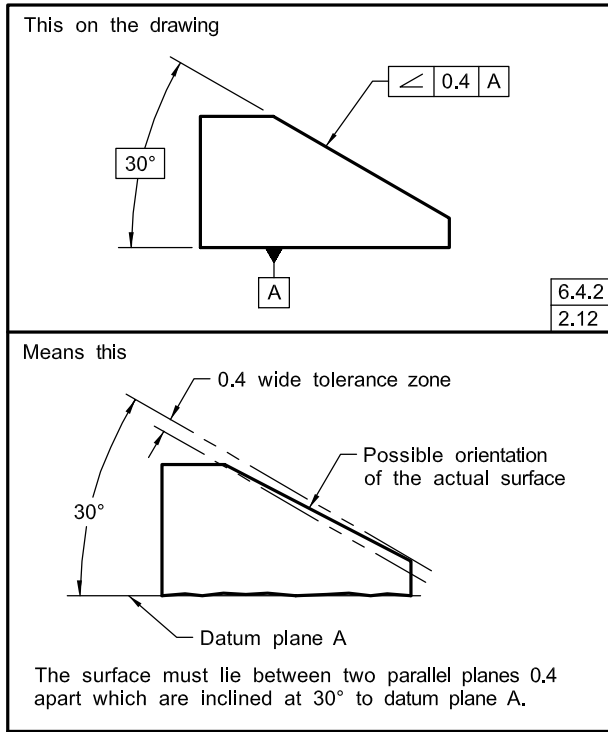
(c) a cylindrical tolerance zone at the specified basic angle from, parallel to, or perpendicular to one or more datum planes or a datum axis, within which the axis of the considered feature must lie. See Figs. 6-8 through 6-15.

(d) a tolerance zone defined by two parallel lines at the specified basic angle from, parallel to, or perpendicular to a datum plane or axis, within which the line element of the surface must lie. See Figs. 6-16 and 6-17.

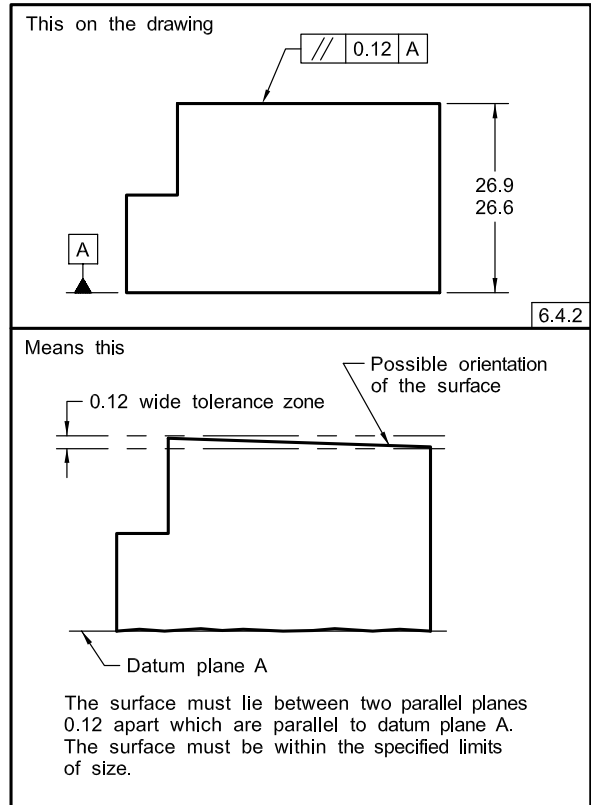
#### 6.4.3 Tolerance Zones

Tolerance zones apply to the full extent of the feature, unless otherwise indicated. Where it is a requirement to control only individual line elements of a surface, a qualifying notation, such as EACH ELEMENT or EACH RADIAL ELEMENT, is added to the drawing. See Figs. 6-16 and 6-17. This permits control of individual elements of the surface independently in relation to the datum and does not limit the total surface to an

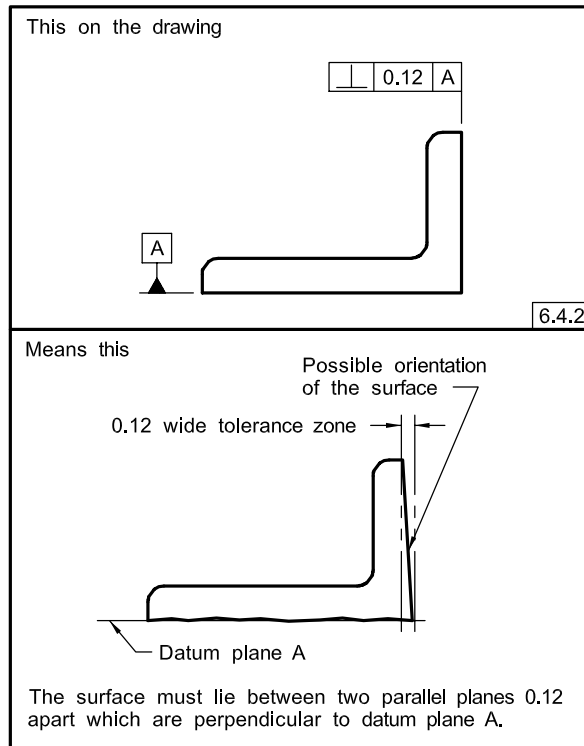
**Fig. 6-1 Specifying Angularity for a Plane Surface**



**Fig. 6-2 Specifying Parallelism for a Plane Surface**

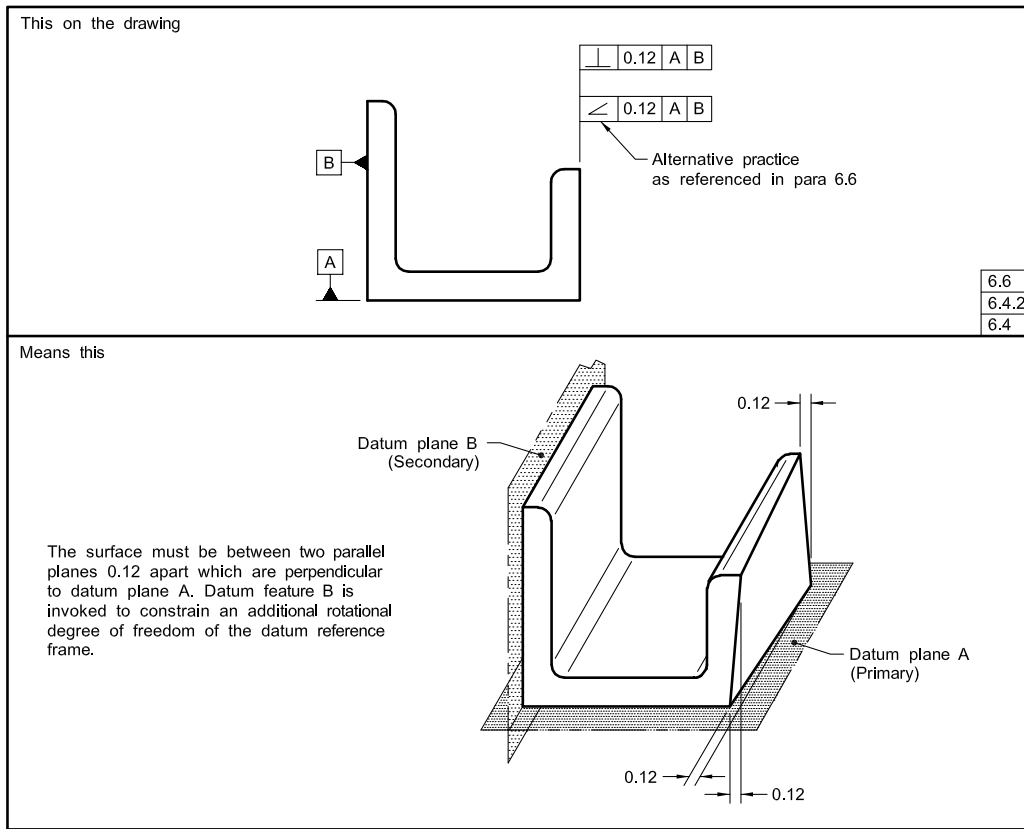


**Fig. 6-3 Specifying Perpendicularity for a Plane Surface**

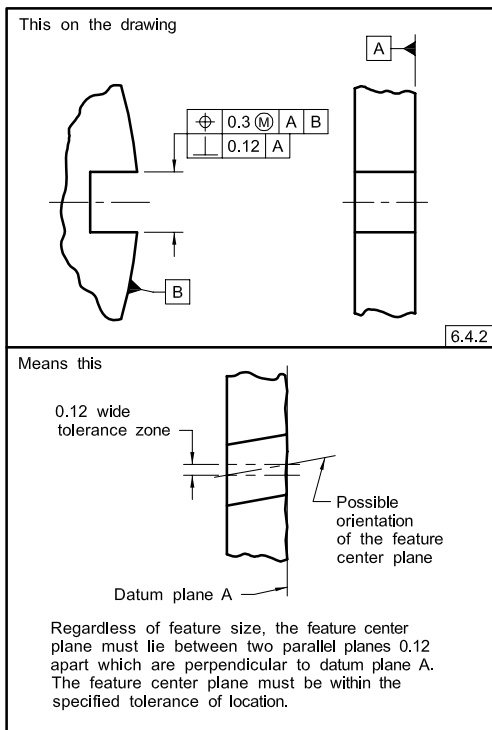




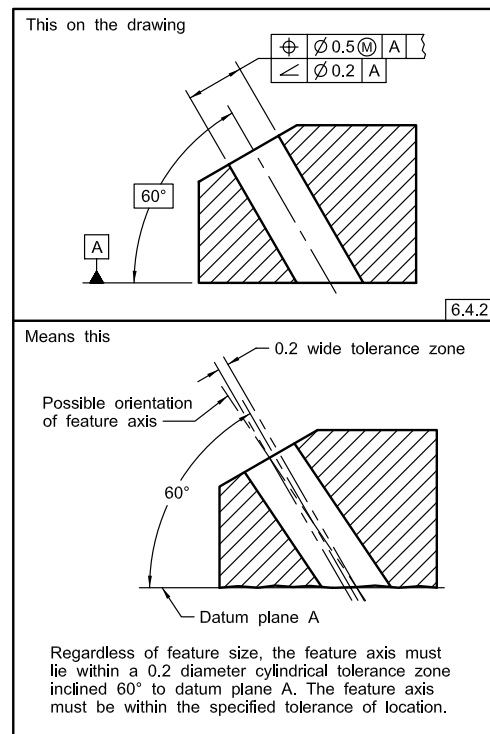
**Fig. 6-4 Specifying Orientation for a Plane Surface Relative to Two Datums**



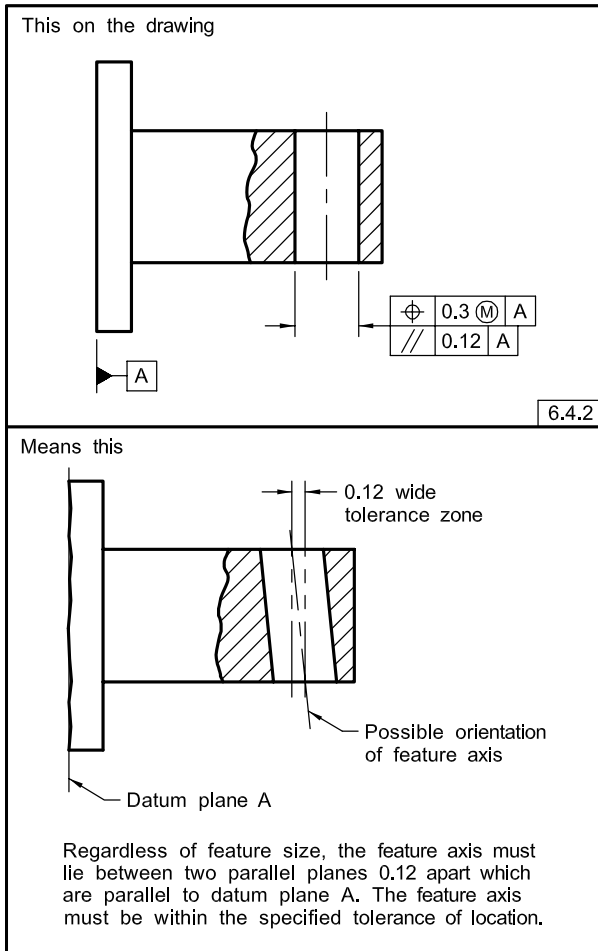
**Fig. 6-5 Specifying Perpendicularity for a Center Plane (Feature RFS)**



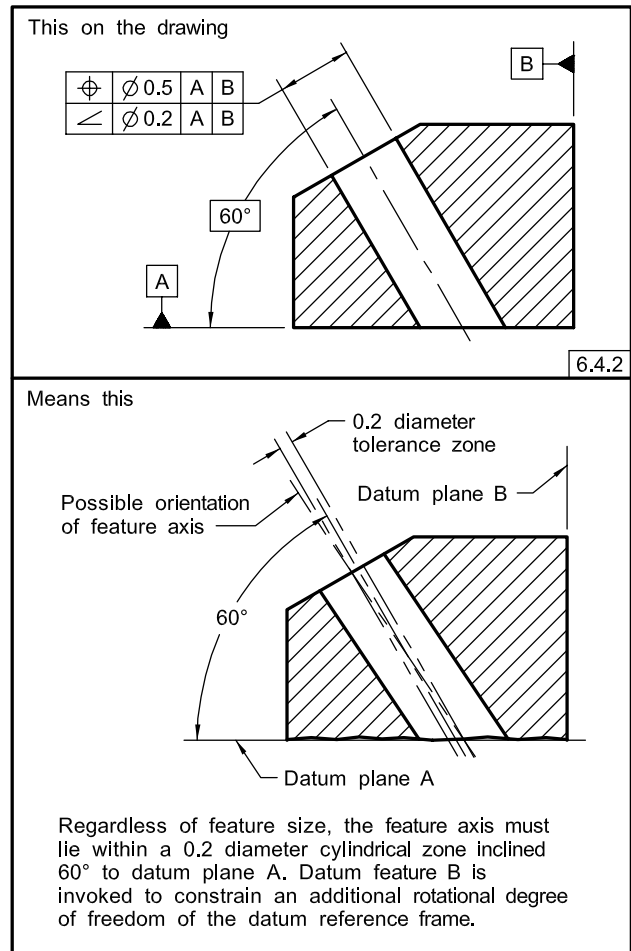
**Fig. 6-6 Specifying Angularity for an Axis (Feature RFS)**



**Fig. 6-7 Specifying Parallelism for an Axis (Feature RFS)**



**Fig. 6-8 Specifying Angularity for an Axis (Feature RFS)**



encompassing zone. Although orientation tolerances are only constrained in rotational degrees of freedom relative to the referenced datums, the notation of EACH RADIAL ELEMENT adds a requirement for the tolerance zone(s) to be constrained in location relative to the axis from which the radial elements emanate. Tolerances for individual elements may also be specified using a line profile tolerance.

**6.4.4 Application of Zero Tolerance at MMC**

Where no variations of orientation are permitted at the MMC size limit of a feature of size, the feature control frame contains a zero for the tolerance, modified by the symbol for MMC. If the feature of size is at its MMC limit of size, it must be perfect in orientation with respect to the datum. A tolerance can exist only as the feature of size departs from MMC. The allowable orientation tolerance is equal to the amount of such departure. See Figs. 6-14 and 6-15. These principles are also applicable to features of size toleranced for orientation at LMC. There may be applications where the full additional tolerance allowable may not meet the functional requirements.

In such cases, the amount of additional tolerance may be limited by stating a MAX following the MMC modifier. See Fig. 6-15.

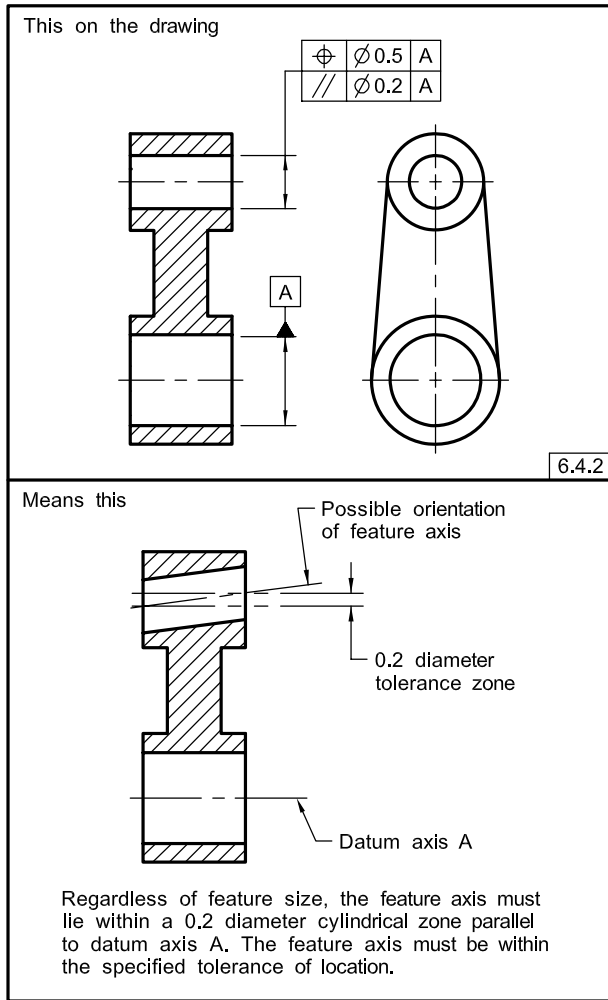
**6.4.5 Explanation of Orientation Tolerance at MMC**

An orientation tolerance applied at MMC may be explained in terms of the surface or the feature axis. In certain cases of extreme form deviation (within limits of size) of the hole, the tolerance in terms of the feature axis may not be exactly equivalent to the tolerance in terms of the surface. In such cases, the surface interpretation shall take precedence as in Fig. 7-6.

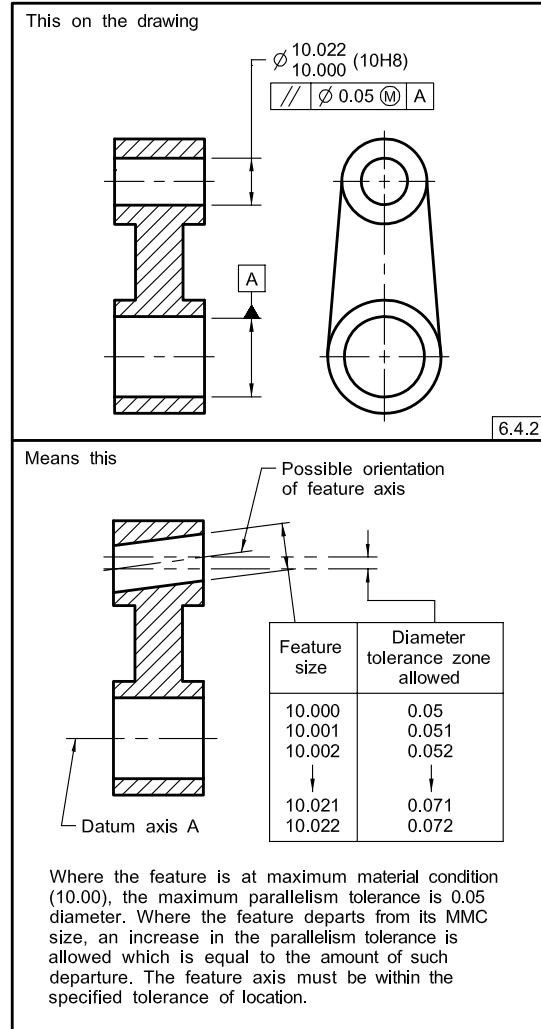
(a) *In Terms of the Surface of a Hole.* While maintaining the specified size limits of the hole, no element of the hole surface shall be inside a theoretical boundary (virtual condition) oriented to the datum reference frame. See Fig. 7-6.

(b) *In Terms of the Axis of a Hole.* Where a hole is at MMC (minimum diameter), the feature axis must fall within a cylindrical tolerance zone whose axis is oriented to the datum reference frame. The diameter of this zone is equal to the orientation tolerance.

**Fig. 6-9 Specifying Parallelism for an Axis (Both Feature and Datum Feature RFS)**



**Fig. 6-10 Specifying Parallelism for an Axis (Feature at MMC and Datum Feature RFS)**



See Fig. 6-14. It is only where the hole is at MMC that the specified tolerance zone applies. Where the unrelated actual mating envelope size of the hole is larger than MMC, additional orientation tolerance results. This increase of orientation tolerance is equal to the difference between the specified maximum material condition limit of size (MMC) and the unrelated actual mating envelope size of the hole. Where the unrelated actual mating envelope size is larger than MMC, the specified orientation tolerance for a hole may be exceeded and still satisfy function and interchangeability requirements.

NOTE: These concepts are equally applicable to all features of size.

### 6.5 TANGENT PLANE

Where it is desired to control a tangent plane established by the contacting points of a surface, the tangent

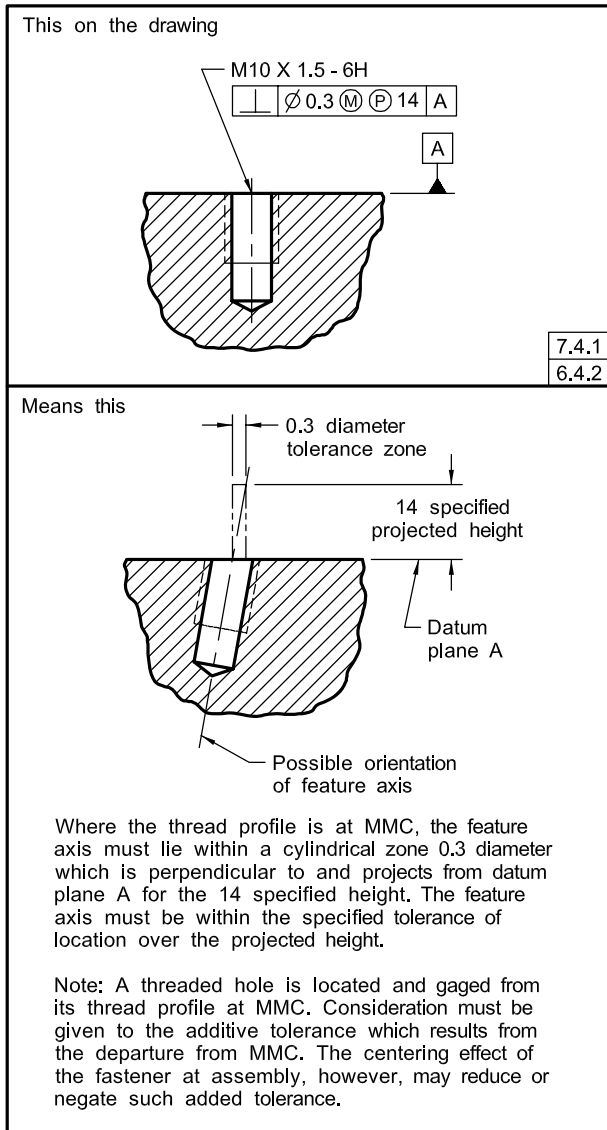
plane symbol is added in the feature control frame after the stated tolerance. See Fig. 6-18. Where a tangent plane symbol is specified with a geometric tolerance, the flatness of the tolerated feature is not controlled by the geometric tolerance. Where the tangent plane rocks on a convex surface, see ASME Y14.5.1M for methods of verification.

NOTE: The tangent plane symbol is illustrated with orientation tolerances; however, it may also have applications using other geometric characteristic symbols where the feature is related to a datum(s).

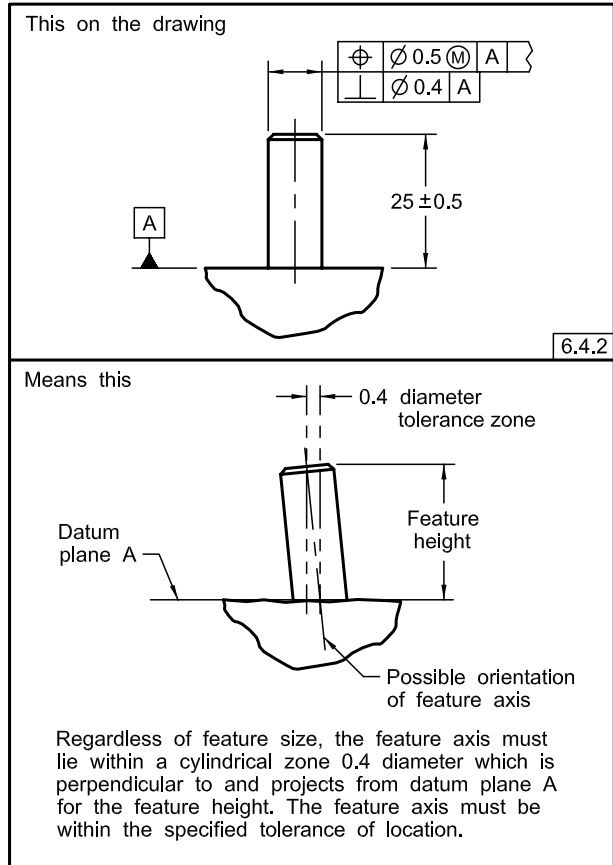
### 6.6 ALTERNATIVE PRACTICE

As an alternative practice, the angularity symbol may be used to control parallel and perpendicular relationships. The tolerance zones derived are the same as those described in para. 6.4.2. See Fig. 6-4.

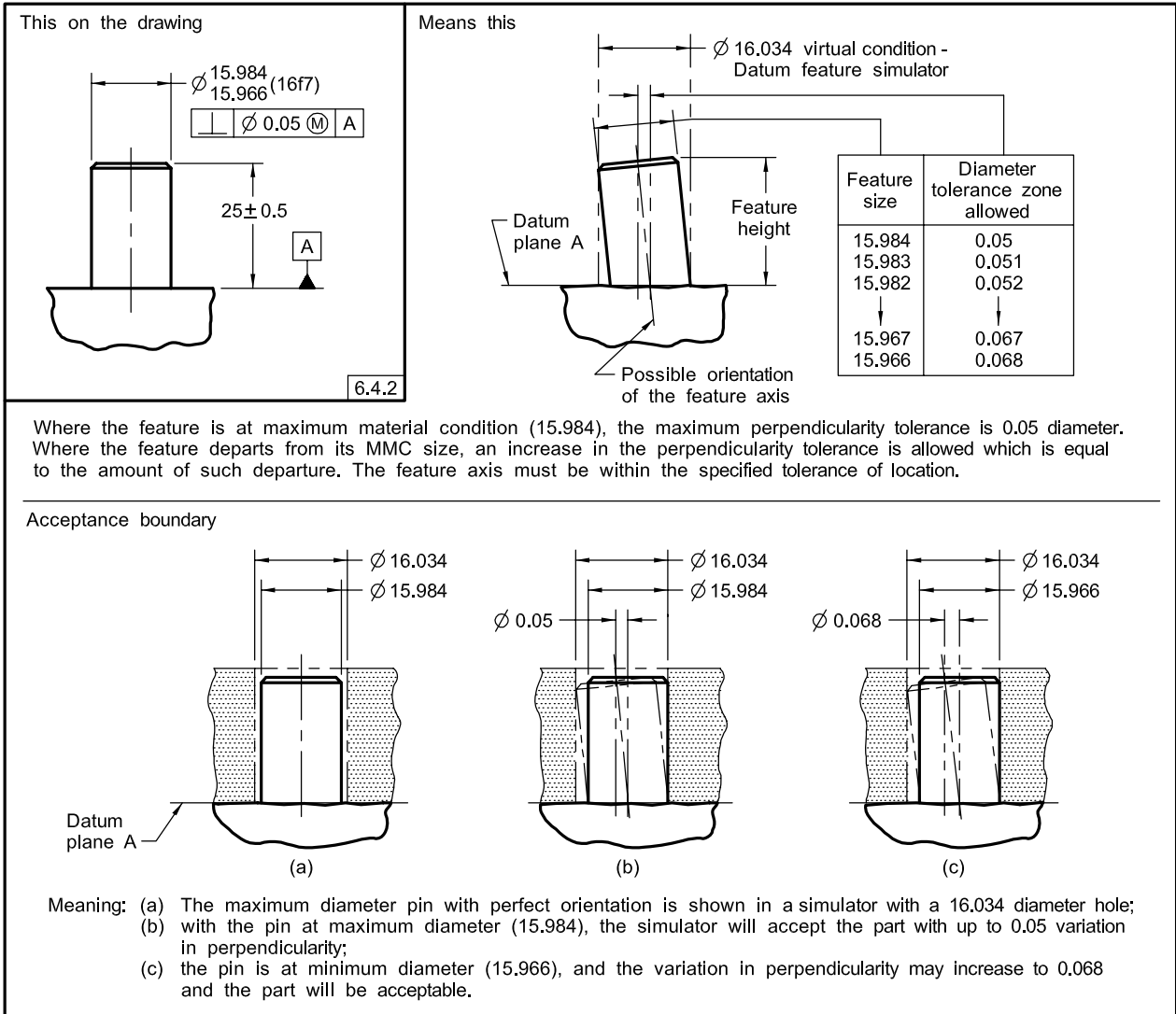
**Fig. 6-11 Specifying Perpendicularity for an Axis at a Projected Height (Threaded Hole or Insert at MMC)**



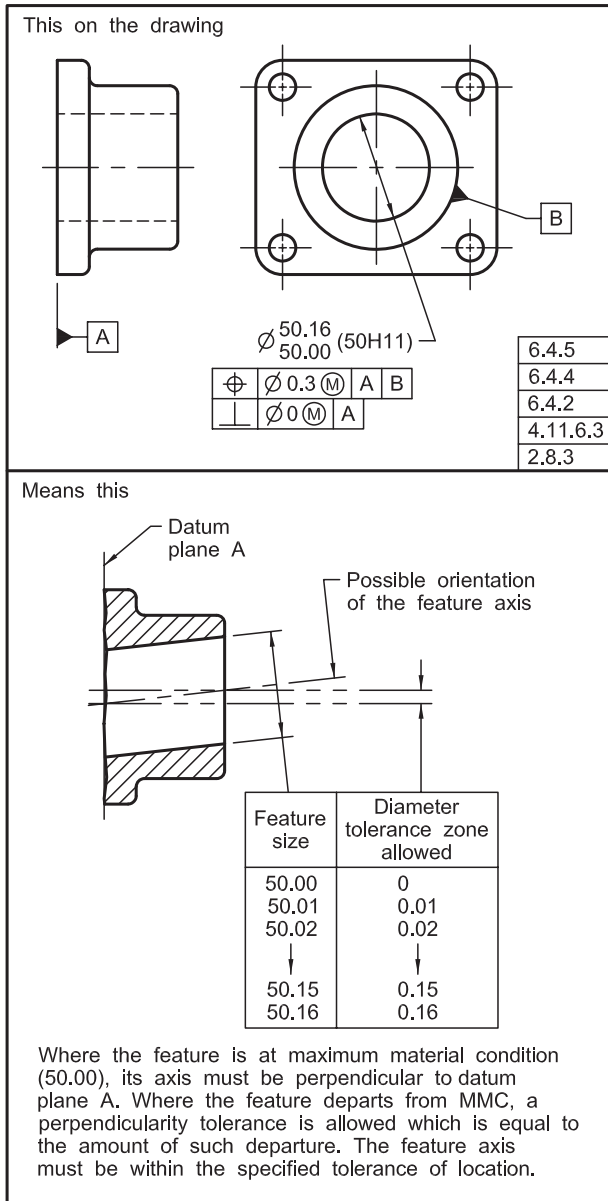
**Fig. 6-12 Specifying Perpendicularity for an Axis (Pin or Boss RFS)**



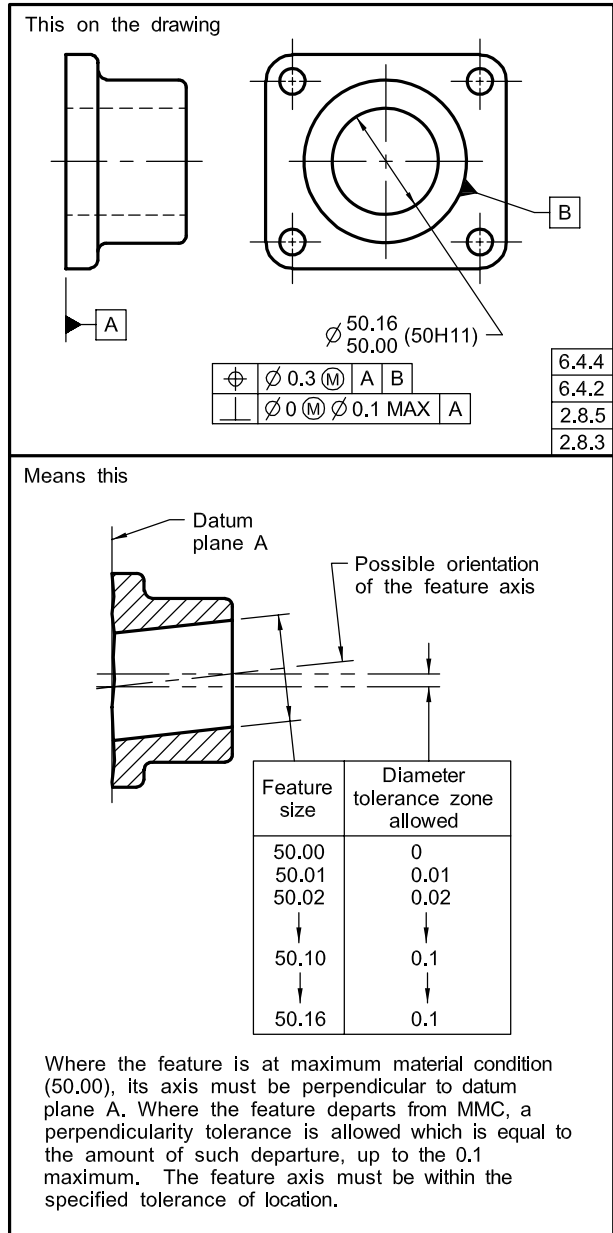
**Fig. 6-13 Specifying Perpendicularity for an Axis Showing Acceptance Boundary (PIN or Boss at MMC)**



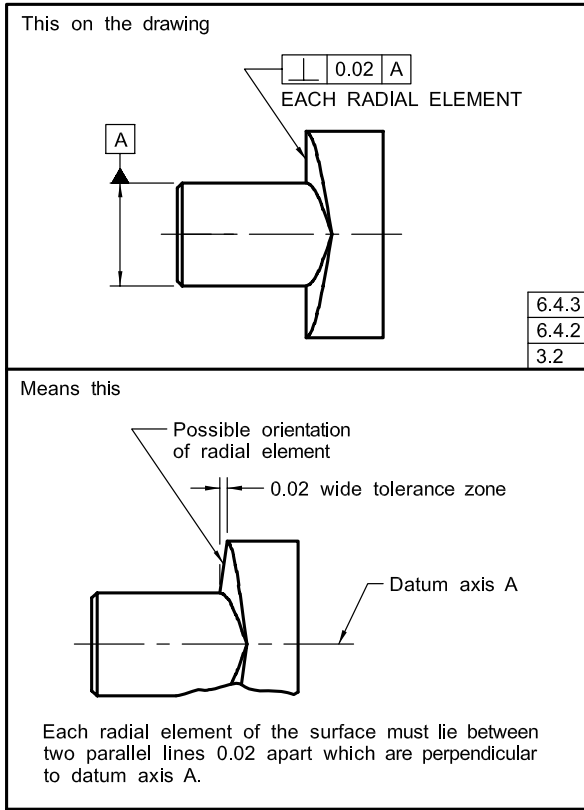
**Fig. 6-14 Specifying Perpendicularity for an Axis (Zero Tolerance at MMC)**



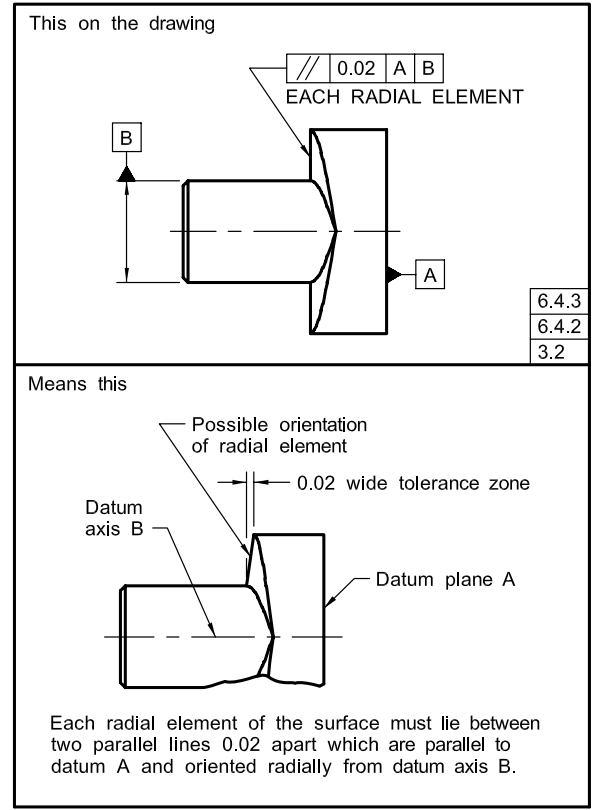
**Fig. 6-15 Specifying Perpendicularity for an Axis (Zero Tolerance at MMC With a Maximum Specified)**



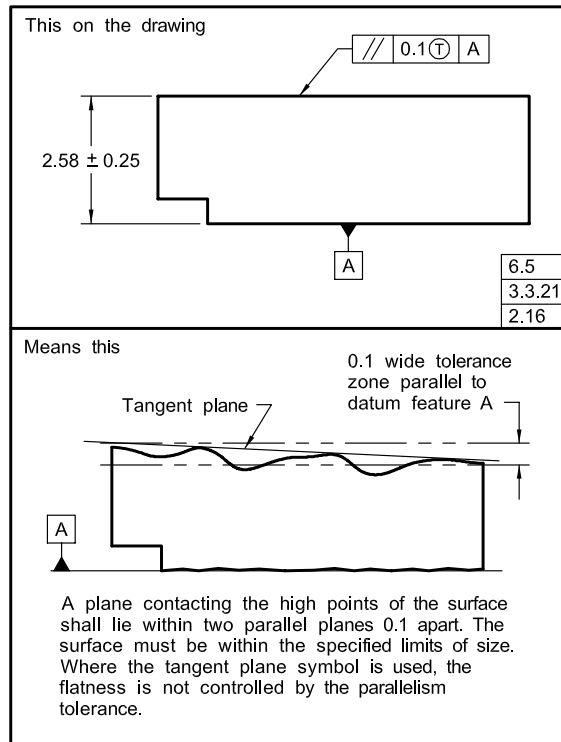
**Fig. 6-16 Specifying Perpendicularity for a Radial Element of a Surface**



**Fig. 6-17 Specifying Perpendicularity for a Radial Element of a Surface**



**Fig. 6-18 Specifying a Tangent Plane**



## Section 7

# Tolerances of Location

### 7.1 GENERAL

This Section establishes the principles of tolerances of location. Included are position, concentricity, and symmetry used to control the following relationships:

- (a) center distance between features of size such as holes, slots, bosses, and tabs
- (b) location of features of size [such as in subpara. (a) above] as a group, from datum features, such as plane and cylindrical surfaces
- (c) coaxiality of features of size
- (d) concentricity or symmetry of features of size—center distances of correspondingly located feature elements equally disposed about a datum axis or plane

### 7.2 POSITIONAL TOLERANCING

Position is the location of one or more features of size relative to one another or to one or more datums. A positional tolerance defines either of the following:

- (a) a zone within which the center, axis, or center plane of a feature of size is permitted to vary from a true (theoretically exact) position
- (b) (where specified on an MMC or LMC basis) a boundary, defined as the virtual condition, located at the true (theoretically exact) position, that may not be violated by the surface or surfaces of the considered feature of size.

Basic dimensions establish the true position from specified datums and between interrelated features. A positional tolerance is indicated by the position symbol, a tolerance value, applicable material condition modifiers, and appropriate datum references placed in a feature control frame.

#### 7.2.1 Components of Positional Tolerancing

The following subparagraphs describe the components of positional tolerancing.

**7.2.1.1 Dimensions for True Position.** Dimensions used to locate true position shall be basic and defined in accordance with para. 2.1.1.2. See Fig. 7-1. For applicable notes in digital data files, see ASME Y14.41.

**7.2.1.2 Use of Feature Control Frame.** A feature control frame is added to the notation used to specify the size

and number of features. See Figs. 7-2 through 7-4. These figures show different types of feature pattern dimensioning. Figure 7-3, illustration (b) is a screen image of a digital data file with positional tolerance feature control frames and the required datum feature symbols.

**7.2.1.3 Identifying Features to Establish Datums.** It is necessary to identify features or features of size on a part to establish datums for dimensions locating true positions except where the positioned features establish the primary datum. (The exception is explained in para. 7.6.2.3.) For example, in Fig. 7-2, if datum references had been omitted, it would not be clear whether the inside diameter or the outside diameter was the intended datum feature for the dimensions locating true positions. The intended datum features are identified with datum feature symbols, and the applicable datum feature references are included in the feature control frame. For information on specifying datums in an order of precedence, see para. 4.10.

### 7.3 POSITIONAL TOLERANCING FUNDAMENTALS: I

The following is a general explanation of positional tolerancing.

#### 7.3.1 Material Condition Basis

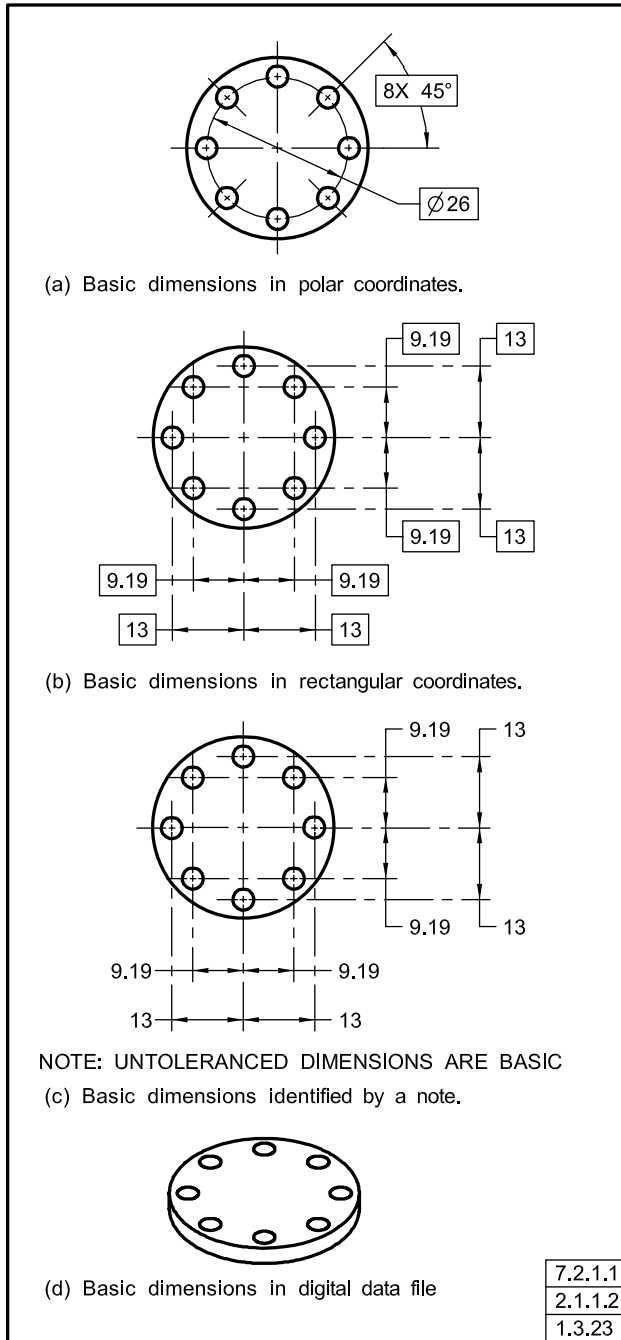
Positional tolerancing is applied on an MMC, RFS, or LMC basis. Where MMC or LMC is required, the appropriate modifier follows the specified tolerance. See para. 2.8.

#### 7.3.2 RFS as Related to Positional Tolerancing

The design or function of a part may require the positional tolerance, datum reference, or both, to be maintained regardless of the features' actual mating envelope sizes. RFS, where applied to the positional tolerance of circular features of size, requires the axis or center point of each feature of size to be located within the specified positional tolerance regardless of the size of the feature. In Fig. 7-5, the six holes may vary in size from 25 to 25.6 diameter. Each hole must be located within the specified positional tolerance regardless of the size of that hole. A positional tolerance applied at RFS is more restrictive than the same positional tolerance applied at MMC or LMC.



**Fig. 7-1 Identifying Basic Dimensions**



**7.3.3 MMC as Related to Positional Tolerancing**

The positional tolerance and maximum material condition of mating features are considered in relation to each other.

**7.3.3.1 Explanation of Positional Tolerance at MMC.**

A positional tolerance applied at MMC may be explained in terms of the surface or the axis of the feature of size. In certain cases of extreme form deviation (within limits of size) or orientation deviation of the hole, the tolerance in terms of the axis may not be exactly equivalent to the tolerance in terms of the surface. See Fig. 7-6. In such cases, the surface interpretation shall take precedence. In some instances, the additional tolerance may indirectly benefit features other than the one that departed from MMC.

(a) *Surface Interpretation.* While maintaining the specified size limits of the feature, no element of the surface shall violate a theoretical boundary (virtual condition) located at true position. See Fig. 7-7.

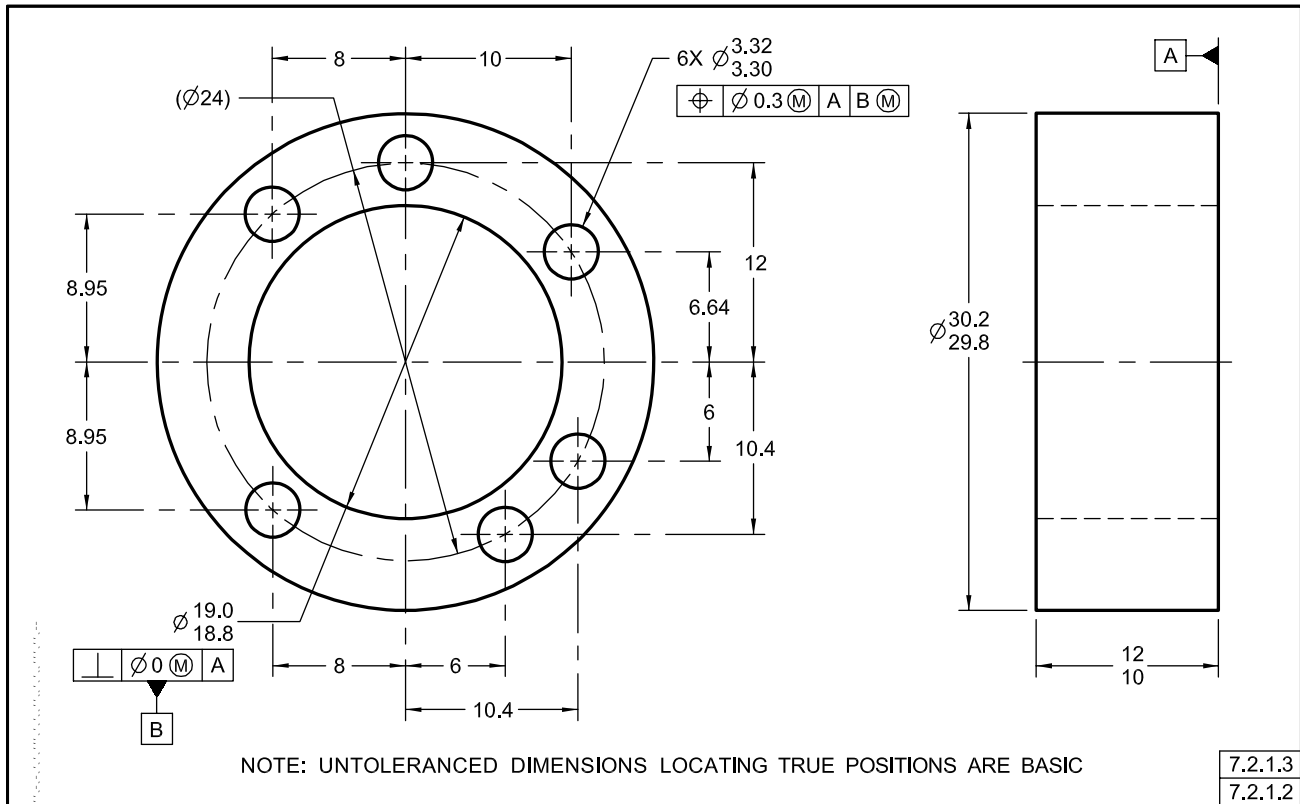
(b) *Axis or Center Plane Interpretation.* Where a feature of size is at MMC, its axis or center plane must fall within a tolerance zone located at true position. The size of this zone is equal to the positional tolerance. See Fig. 7-8, illustrations (a) and (b). This tolerance zone also defines the limits of variation in the orientation of the axis or center plane of the feature of size in relation to the datum surface. See Fig. 7-8, illustration (c). It is only where the feature of size is at MMC that the specified tolerance zone applies. Where the unrelated actual mating envelope size of the feature of size departs from MMC, additional positional tolerance results. See Fig. 7-9. This increase of positional tolerance is equal to the difference between the specified maximum material condition limit of size (MMC) and the unrelated actual mating envelope size. Where the unrelated actual mating envelope size has departed from MMC, the specified positional tolerance for a feature of size may be larger than the stated value and still satisfy function and interchangeability requirements.

**7.3.3.2 Calculating Positional Tolerance.**

Figure 7-10 shows a drawing for one of two identical plates to be assembled with four 14-mm maximum diameter fasteners. The 14.25 minimum diameter clearance holes are selected with a size tolerance as shown. The required positional tolerance is found by the equation and other considerations as given in Nonmandatory Appendix B. The shown formula does not accommodate factors other than hole and fastener diameter tolerances.

$$\begin{aligned}
 T &= H - F \\
 &= 14.25 - 14 \\
 &= 0.25 \text{ diameter}
 \end{aligned}$$

Fig. 7-2 Positional Tolerancing With Datum References



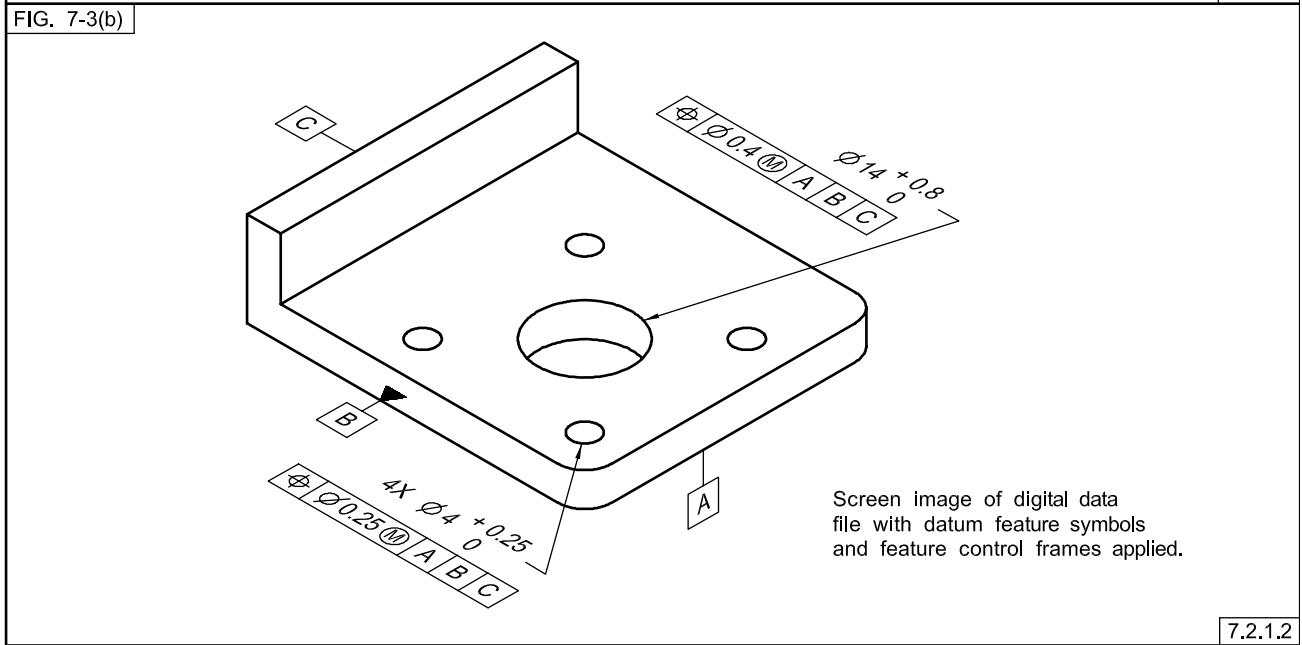
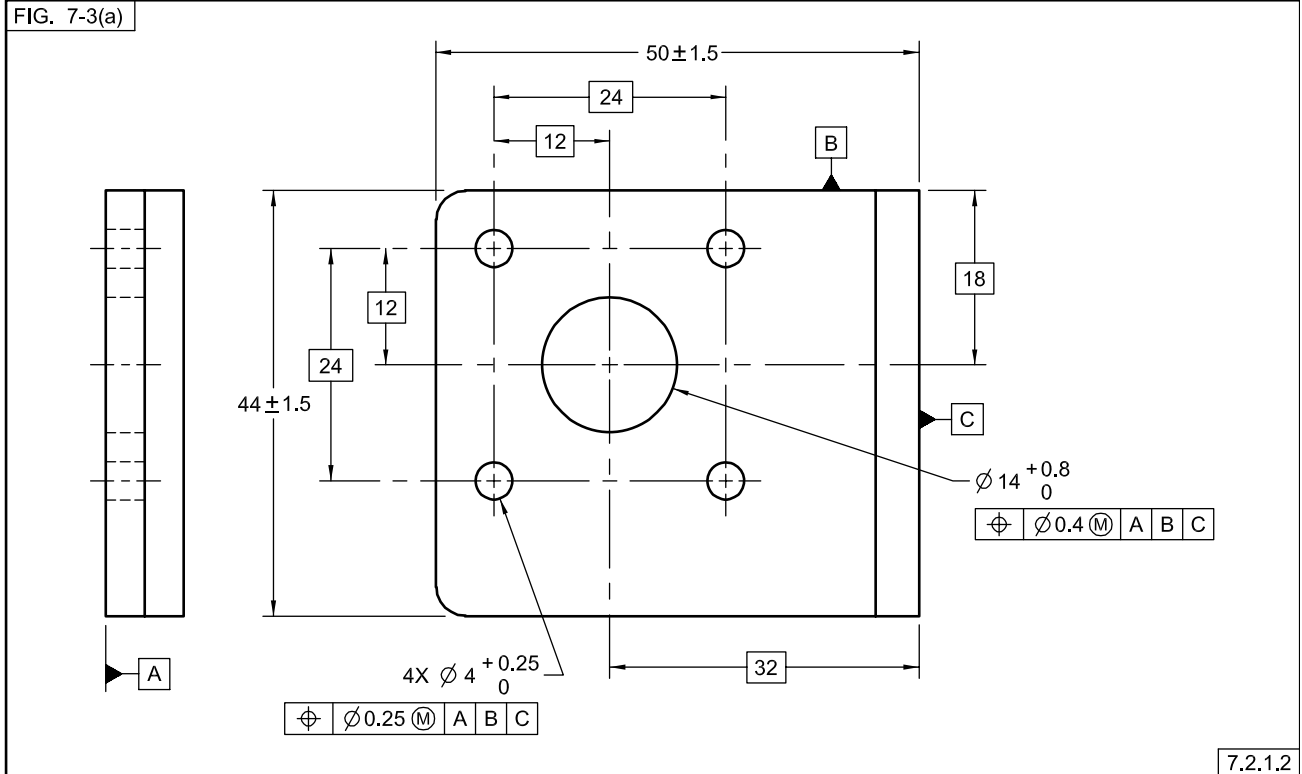
NOTE: If the clearance holes were located exactly at true position, the parts would still assemble with clearance holes as small as 14 diameter (or slightly larger). However, otherwise usable parts having clearance holes smaller than 14.25 diameter would be rejected for violating size limits.

### 7.3.4 Zero Positional Tolerance at MMC

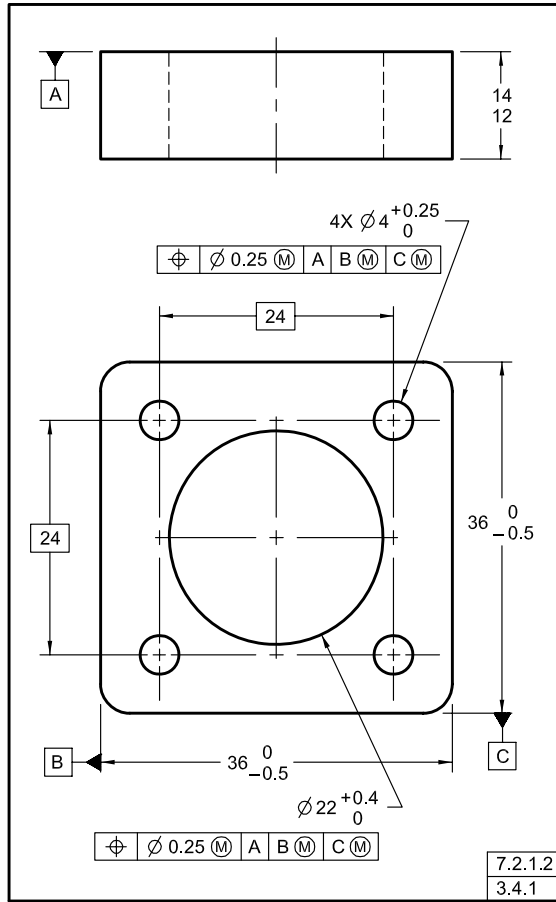
The application of MMC permits the position tolerance zone to increase larger than the value specified, provided the features of size are within size limits, and the feature of size locations are such as to make the part acceptable. However, rejection of usable parts can occur where these features of size are actually located on or close to their true positions, but produced to a size smaller than the specified minimum (outside of limits). The principle of positional tolerancing at MMC allows the maximum amount of tolerance for the function of assembly. This is accomplished by adjusting the

minimum size limit of a hole to the absolute minimum required for insertion of an applicable maximum fastener located precisely at true position, and specifying a zero positional tolerance at MMC. In this case, the positional tolerance allowed is totally dependent on the unrelated actual mating envelope size of the considered feature, as explained in para. 2.8.3. Figure 7-11 shows a drawing of the same part with a zero positional tolerance at MMC specified. Note that the maximum size limit of the clearance holes remains the same, but the minimum was adjusted to correspond with a 14-mm diameter fastener. This results in an increase in the size tolerance for the clearance holes, with the increase being equal to the positional tolerance specified in Fig. 7-10. Although the positional tolerance specified in Fig. 7-11 is zero at MMC, the positional tolerance allowed increases directly with the actual clearance hole size as shown by the following tabulation:

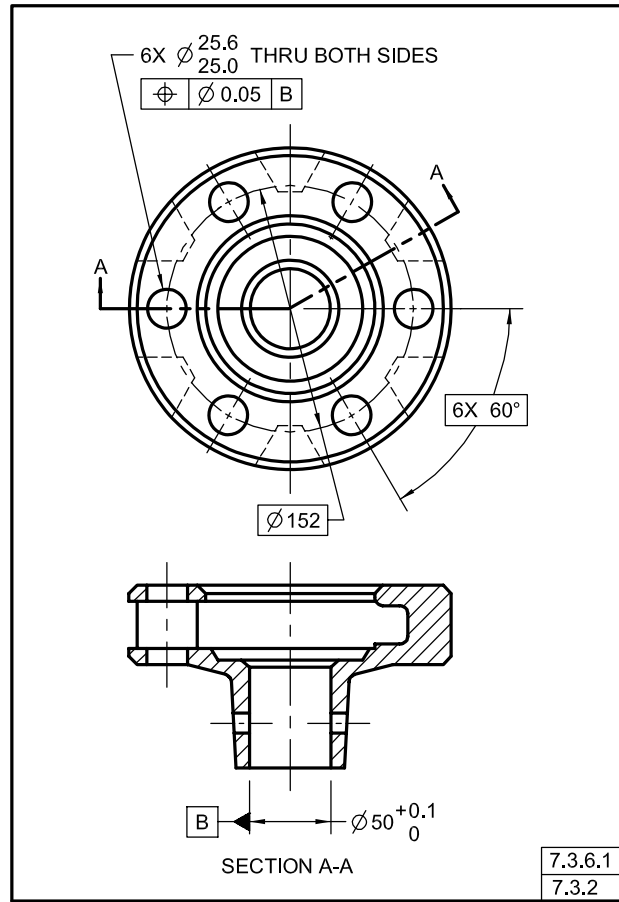
**Fig. 7-3 Positional Tolerancing Relative to Plane Datum Feature Surfaces**



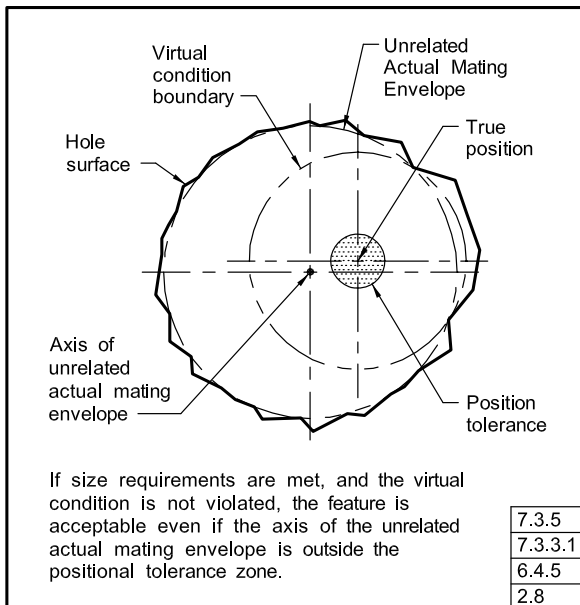
**Fig. 7-4 Positional Tolerancing at MMC Relative to Datum Feature Center Planes**



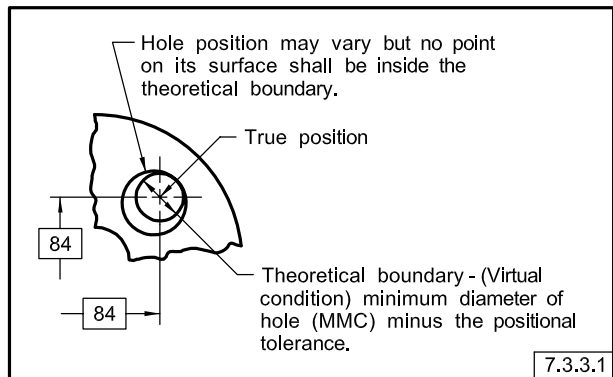
**Fig. 7-5 RFS Applied to a Feature and RMB to a Datum Feature Reference**



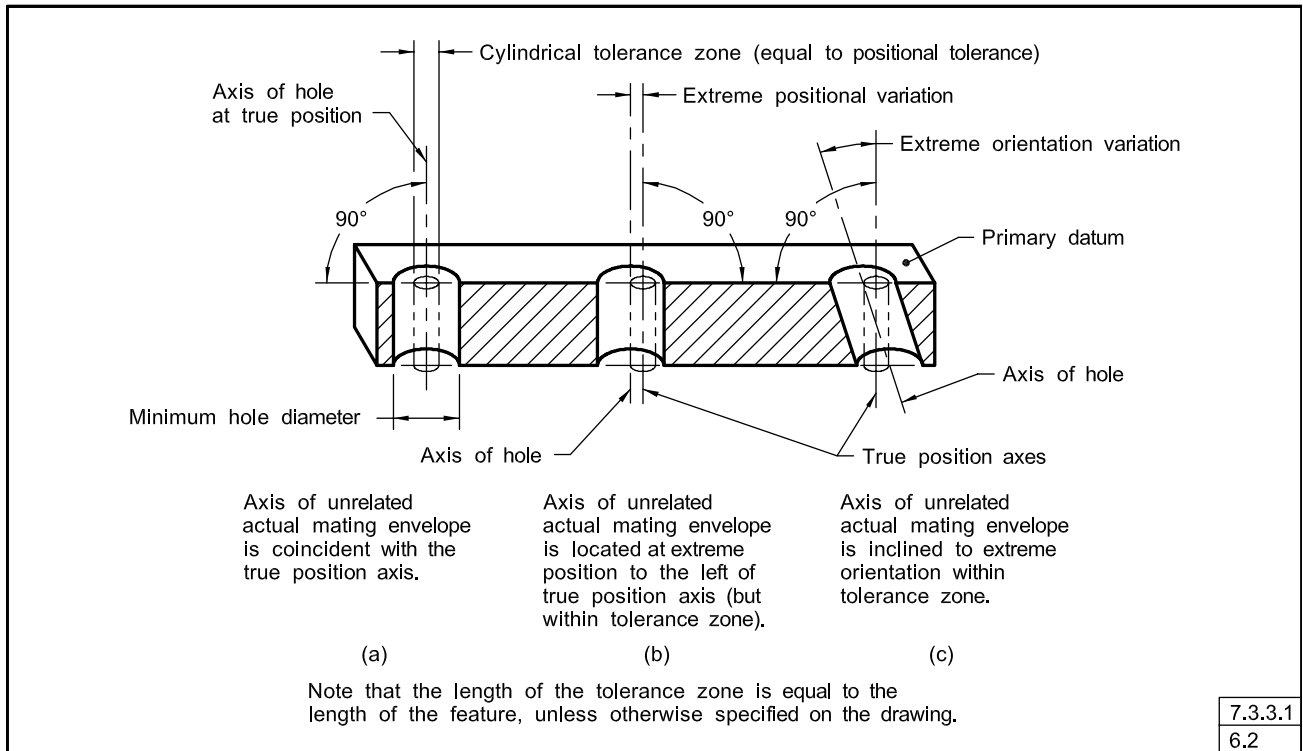
**Fig. 7-6 Illustration of Difference Between Surface and Axis Interpretations of Position Tolerancing for a Cylindrical Hole**



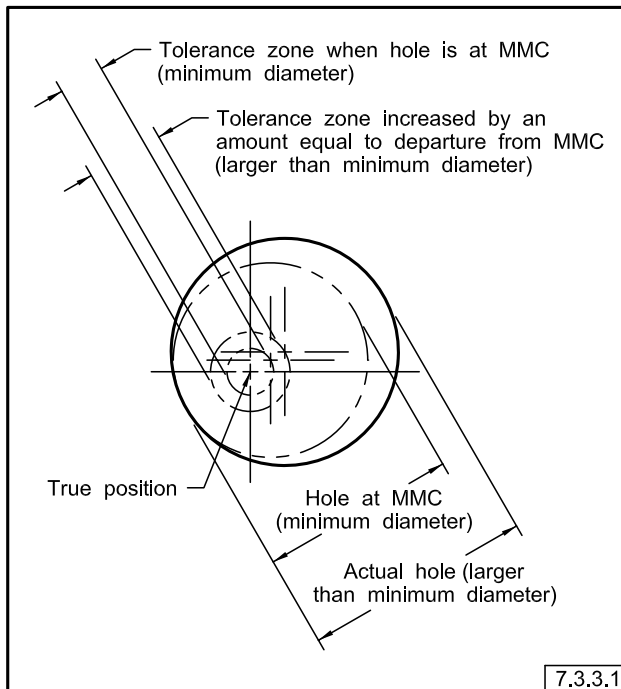
**Fig. 7-7 Boundary for Surface of Hole at MMC**



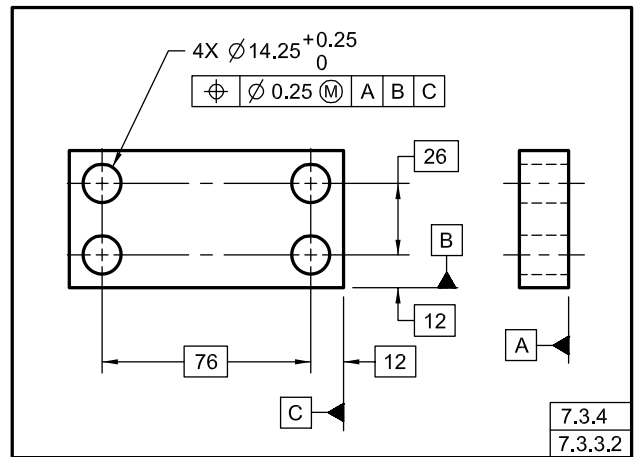
**Fig. 7-8 Hole Axes in Relation to Positional Tolerance Zones**



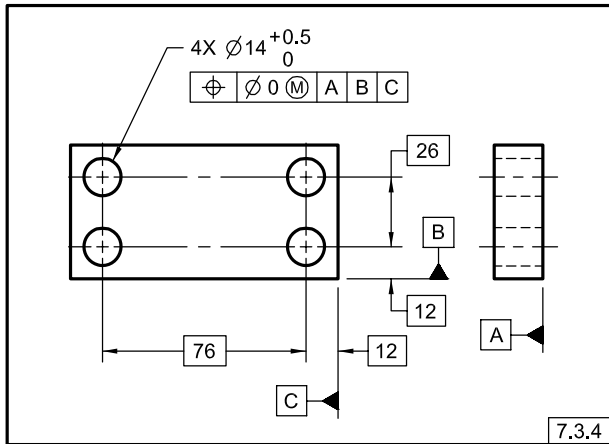
**Fig. 7-9 Increase in Positional Tolerance Where Hole Is Not at MMC**



**Fig. 7-10 Positional Tolerancing at MMC**



**Fig. 7-11 Zero Positional Tolerancing at MMC**



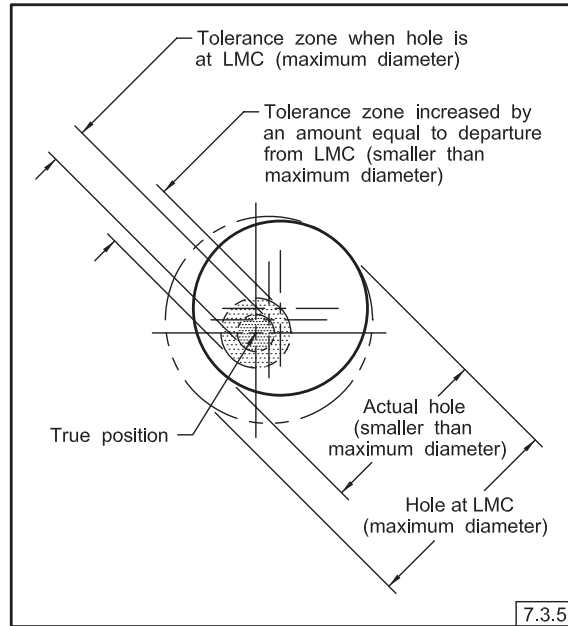
Clearance Hole Diameter (Feature Actual Mating Size)	Positional Tolerance Diameter Allowed
14	0
14.1	0.1
14.2	0.2
14.25	0.25
14.3	0.3
14.4	0.4
14.5	0.5

**7.3.5 LMC as Related to Positional Tolerancing**

Where positional tolerancing at LMC is specified, the stated positional tolerance applies at the feature size limit that results in the least material in the part. Specification of LMC requires perfect form at LMC. Perfect form at MMC is not required. Where the feature departs from its LMC limit of size, an increase in positional tolerance is allowed, equal to the amount of such departure. See Fig. 7-12. LMC may be specified in positional tolerancing applications where the functional consideration is to ensure a minimum distance is maintained while allowing an increase in tolerance as the feature of size departs from LMC. See Figs. 7-13 through 7-17. LMC is used to maintain a desired relationship between the surface of a feature and its true position at tolerance extremes. As with MMC, the surface interpretation shall take precedence over the axis interpretation. See para. 7.3.3.1 and Fig. 7-6.

**7.3.5.1 LMC to Protect Wall Thickness.** Figure 7-13 illustrates a boss and hole combination located by basic dimensions. Wall thickness is minimum where the boss and hole are at their LMC sizes and both features of size are displaced in opposite extremes. As each feature of size departs from LMC, the wall thickness may increase. The departure from LMC permits a corresponding increase in the positional tolerance, thus maintaining the desired minimum wall thickness between these surfaces.

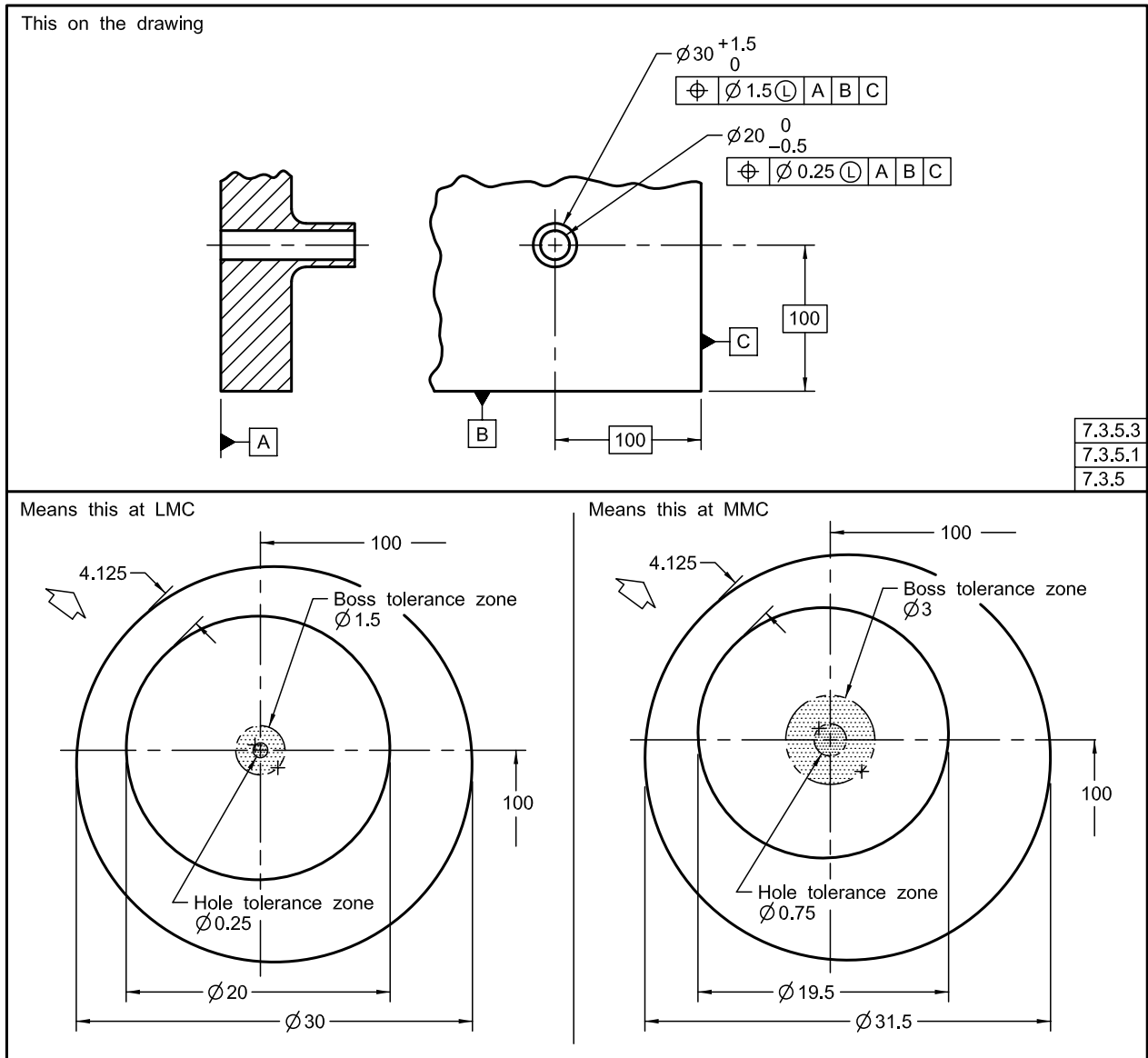
**Fig. 7-12 Increase in Positional Tolerance Where Hole Is Not at LMC**



**7.3.5.2 LMC Applied to Single Features of Size.** LMC may also be applied to single features of size, such as the hole shown in Fig. 7-15. In this example, the position of the hole relative to the inside web is critical. RFS can be specified. However, LMC is applied, permitting an increase in the positional tolerance while protecting the wall thickness.

**7.3.5.3 Zero Positional Tolerance at LMC.** The application of LMC permits the tolerance to exceed the value specified, provided features of size are within size limits, and the feature of size locations are such as to make the part acceptable. However, rejection of usable parts can occur where features of size such as holes are actually located on or close to their true positions, but produced to a size larger than the specified maximum (outside of size limits). The principle of zero positional tolerancing at LMC can be extended in applications where it is desired to protect a minimum distance on a part and allow an increase in tolerance when the tolerated feature departs from LMC. This is accomplished by adjusting the maximum size limit of a hole to the absolute maximum allowed to meet functional requirements (such as wall thickness) while specifying a zero positional tolerance at LMC. When this is done, the positional tolerance allowed is totally dependent on the actual minimum material size of the considered feature of size. Figure 7-14 shows the same drawing as Fig. 7-13, except the tolerances have been changed to show zero positional tolerance at LMC. Note that the minimum size limit of the hole remains the same, but the maximum was adjusted to correspond with a 20.25-diameter virtual condition. This results in an

**Fig. 7-13 LMC Applied to Boss and Hole**



increase in the size tolerance for the hole, the increase being equal to the positional tolerance specified in Fig. 7-13. Although the positional tolerance specified in Fig. 7-14 is zero at LMC, the positional tolerance allowed is directly related to the minimum hole size as shown by the following tabulation.

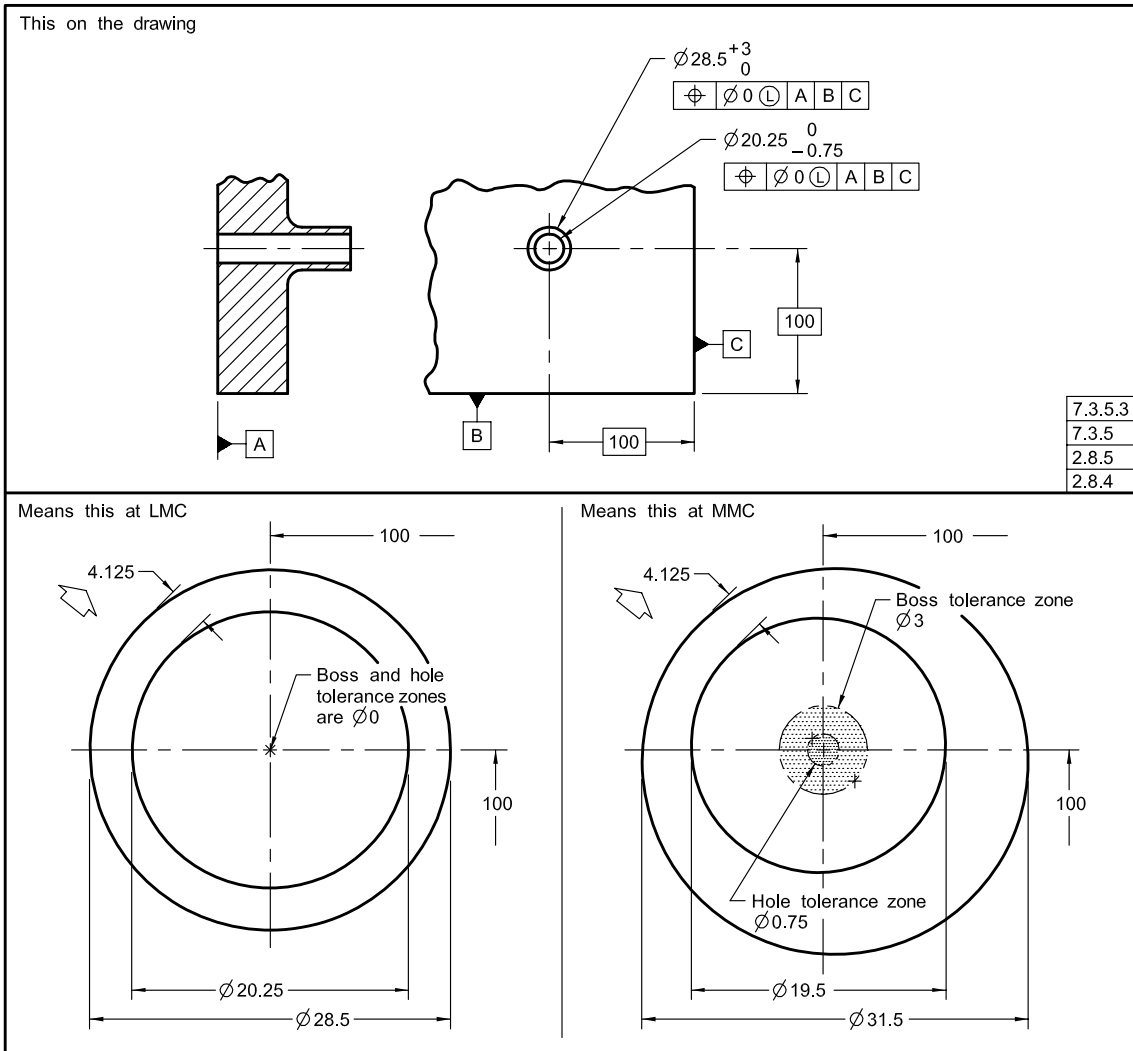
Hole Diameter (Feature Minimum Material Size)	Positional Tolerance Diameter Allowed
20.25	0
20.00	0.25
19.75	0.50
19.50	0.75

**7.3.6 Datum Feature Modifiers in Positional Tolerances**

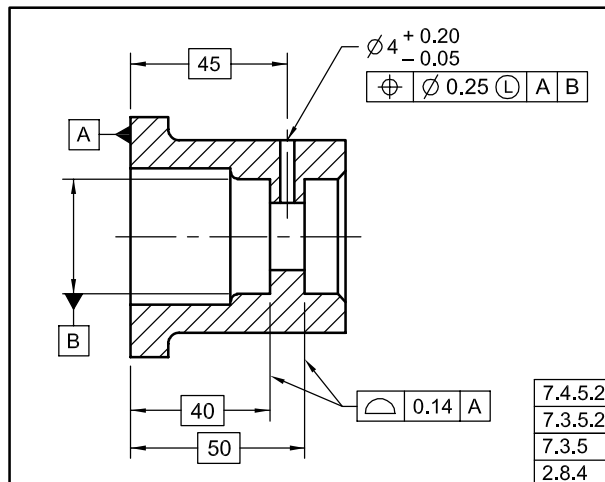
References to datum features of size shall be made regardless of material boundary (RMB), at maximum material boundary (MMB), or at least material boundary (LMB).

**7.3.6.1 Datum Features at RMB.** The functional requirements of some designs may require that RMB be applied to a datum feature. That is, it may be necessary to require the axis of an actual datum feature (such as datum diameter B in Fig. 7-5) to be the datum axis for the holes in the pattern regardless of the datum feature's size. The RMB application does not permit any

**Fig. 7-14 Zero Tolerance at LMC Applied to Boss and Hole**

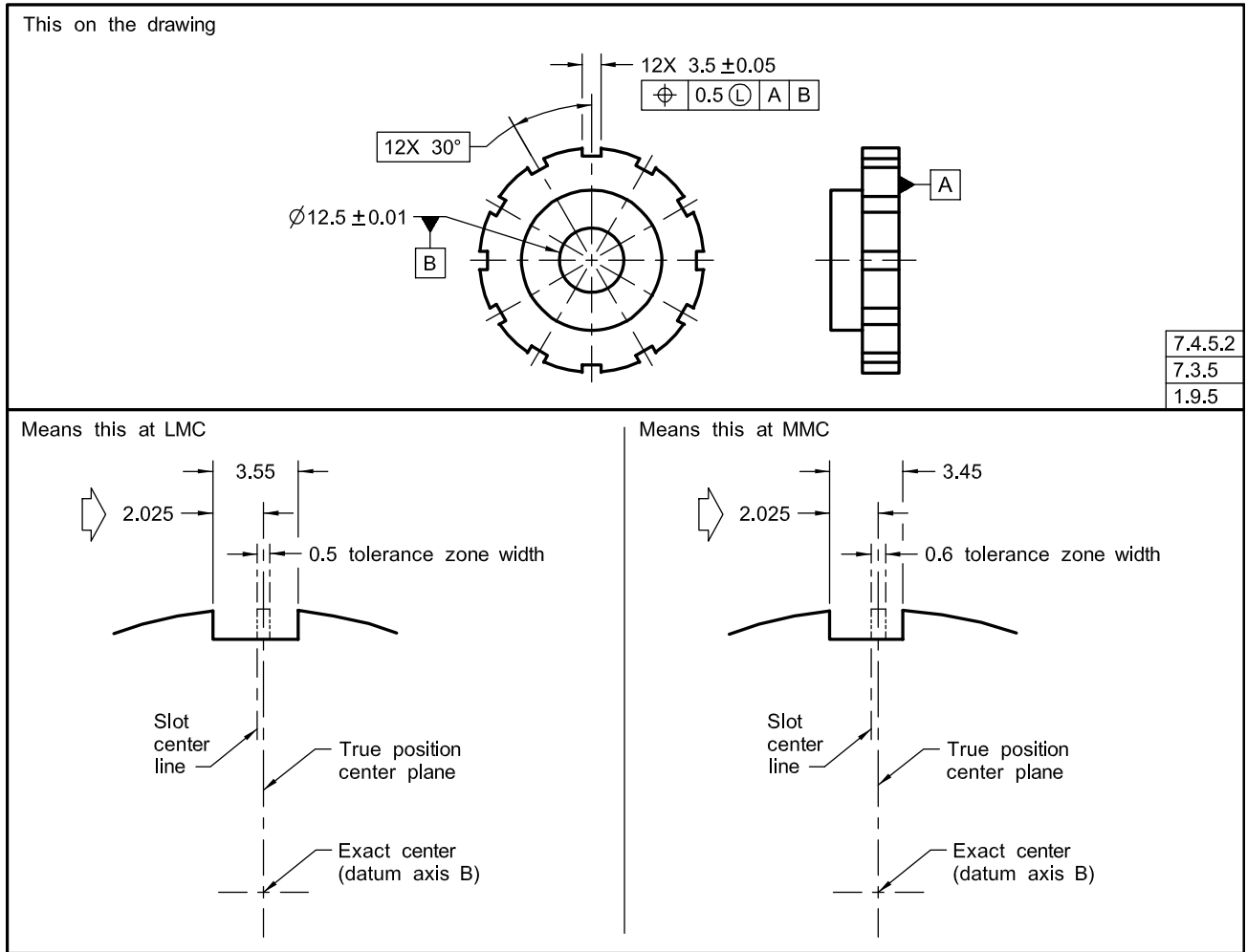


**Fig. 7-15 LMC Applied to a Single Feature**





**Fig. 7-16 LMC Applied to Pattern of Slots**



**Fig. 7-17 Datum Feature at LMB**

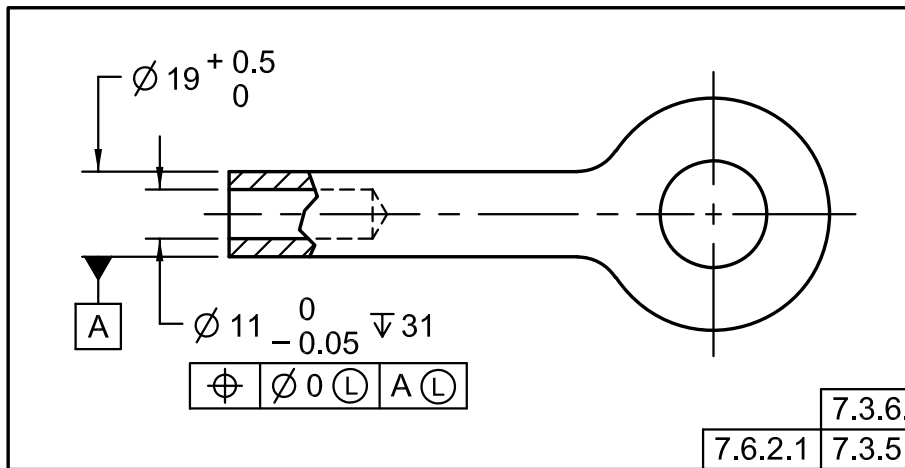
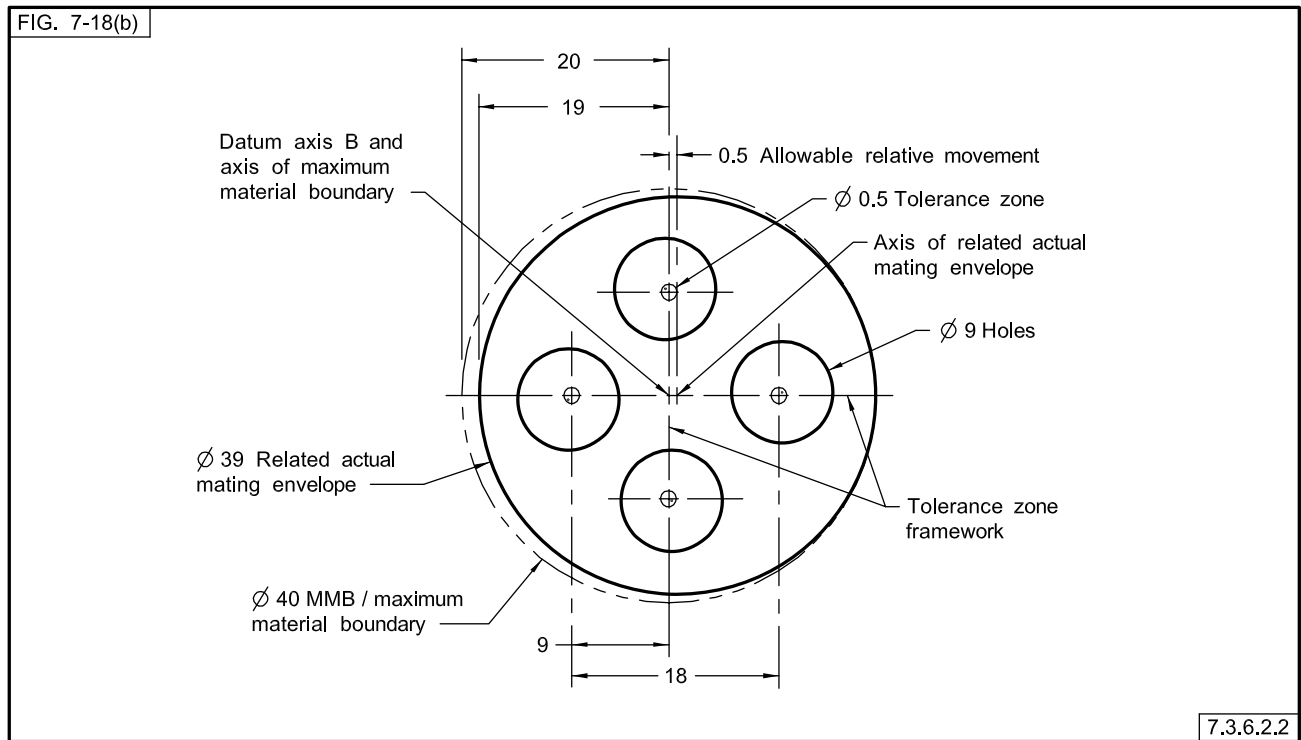




Fig. 7-18 Datum Feature Referenced at MMB (Cont'd)



between datum axis B and the axis of the related actual mating envelope of datum feature B. See para. 4.11.9.

(a) *Effect on Considered Features.* The amount of the datum feature's departure from MMB does not provide additional positional tolerance for each of the considered features in relation to each other within the pattern.

(b) *Inspection Method Variation.* If a functional gage is used to check the part, the relative movement between datum axis B and the axis of the datum feature is automatically accommodated. However, this relative movement must be taken into account if open set-up inspection methods are used.

**7.3.6.3 Displacement Allowed by Datum Features at LMB.** For some applications, a feature or group of features may be positioned relative to a datum feature at LMB. See Fig. 7-17. In such a case, allowable displacement results when the datum feature departs from LMB.

## 7.4 POSITIONAL TOLERANCING FUNDAMENTALS: II

The following expands on the principles of the preceding general explanation of positional tolerancing.

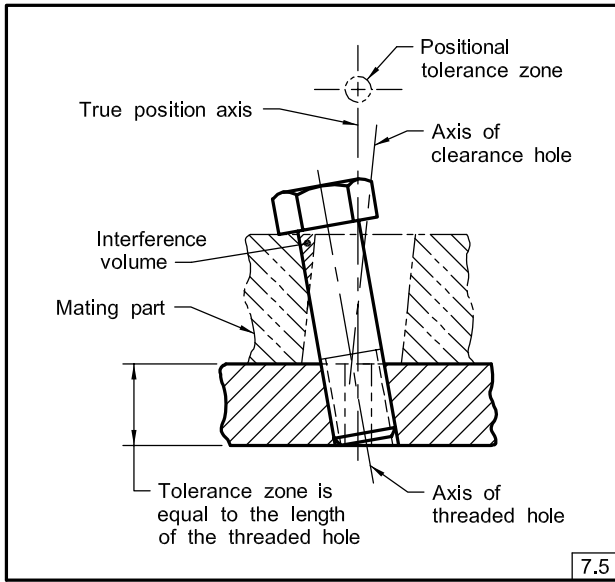
### 7.4.1 Projected Tolerance Zone

The application of this concept is recommended where the variation in perpendicularity of threaded or

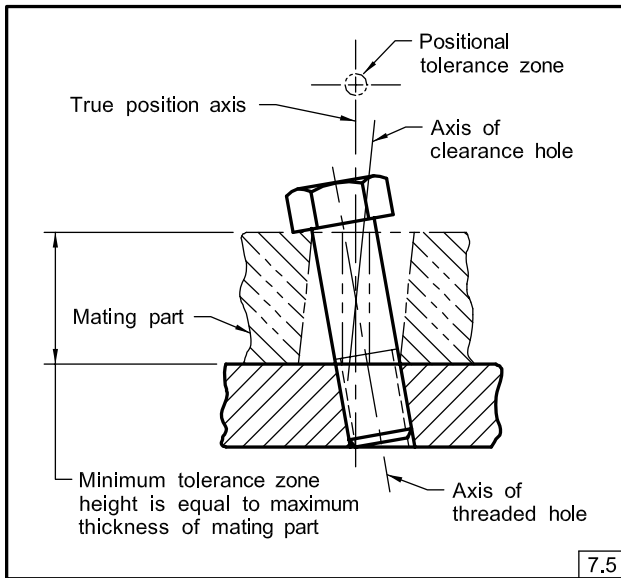
press-fit holes could cause fasteners, such as screws, studs, or pins, to interfere with mating parts. See Fig. 7-19. An interference can occur where a tolerance is specified for the location of a threaded or press-fit hole, and the hole is inclined within the positional limits. Unlike the floating fastener application involving clearance holes only, the attitude of a fixed fastener is governed by the inclination of the produced hole into which it assembles. Figure 7-20 illustrates how the projected tolerance zone concept realistically treats the condition shown in Fig. 7-19. Note that it is the variation in perpendicularity of the portion of the fastener passing through the mating part that is significant. The location and perpendicularity of the threaded hole are only of importance insofar as they affect the extended portion of the engaging fastener. Where design considerations require a closer control in the perpendicularity of a threaded hole than that allowed by the positional tolerance, an orientation tolerance applied as a projected tolerance zone may be specified. See Fig. 6-11. To control the feature within the part, an additional tolerance may be specified. Where a composite or multiple segment feature control frame is used, the projected tolerance zone symbol shall be shown in all applicable segments.

**7.4.1.1 Clearance Holes in Mating Parts.** Specifying a projected tolerance zone will ensure that fixed fasteners do not interfere with mating parts having

**Fig. 7-19 Interference Diagram, Fastener and Hole**

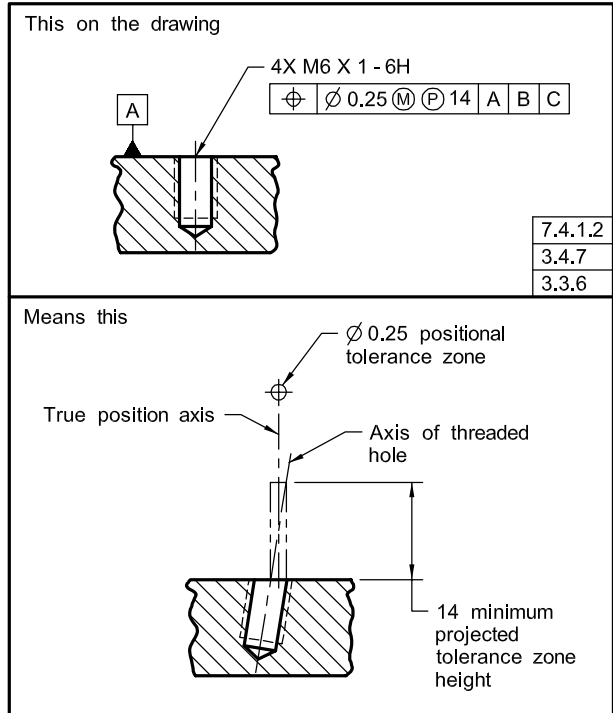


**Fig. 7-20 Basis for Projected Tolerance Zone**

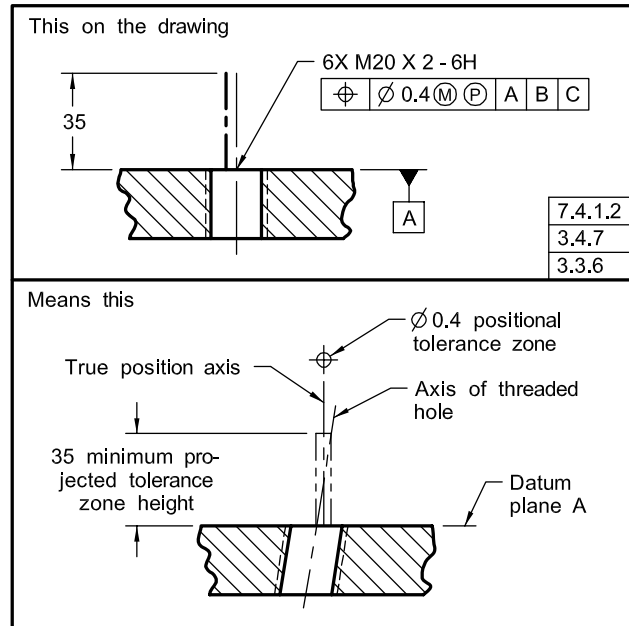


clearance hole sizes determined by the formulas recommended in Nonmandatory Appendix B. Further enlargement of clearance holes to provide for an extreme variation in perpendicularity of the fastener is not necessary.

**Fig. 7-21 Projected Tolerance Zone Specified**

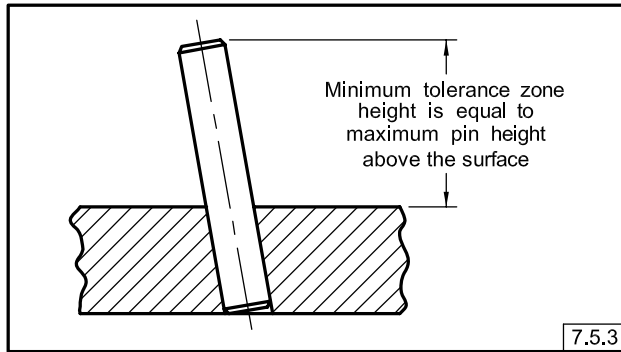


**Fig. 7-22 Projected Tolerance Zone Indicated With Chain Line**



**7.4.1.2 Application.** Figures 7-21 and 7-22 illustrate the application of a positional tolerance using a projected tolerance zone. The specified value for the projected tolerance zone is a minimum and represents the maximum permissible mating part thickness, or the

**Fig. 7-23 Projected Tolerance Zone Applied for Studs or Dowel Pins**



maximum installed length or height of the components, such as screws, studs, or dowel pins. See para. 7.4.1.3. The direction and height of the projected tolerance zone are indicated as illustrated. The minimum extent and direction of the projected tolerance zone are shown in a drawing view as a dimensioned value with a heavy chain line drawn closely adjacent to an extension of the center line of the hole.

**7.4.1.3 Stud and Pin Application.** Where studs or press-fit pins are located on an assembly drawing, the specified positional tolerance applies only to the height of the projecting portion of the stud or pin after installation, and the specification of a projected tolerance zone is unnecessary. However, a projected tolerance zone is applicable where threaded or plain holes for studs or pins are located on a detail part drawing. In these cases, the specified projected height should equal the maximum permissible height of the stud or pin after installation, not the mating part thickness. See Fig. 7-23.

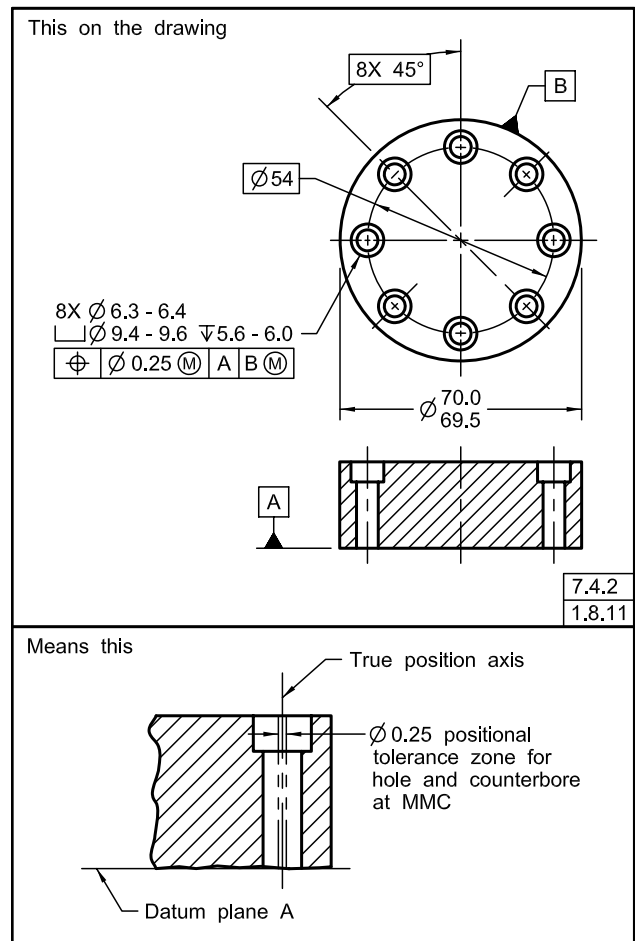
### 7.4.2 Counterbored Holes

Where positional tolerances are used to locate coaxial features, such as counterbored holes, the following practices apply:

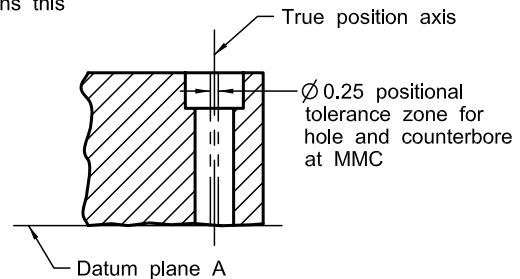
(a) Where the same positional tolerance is used to locate both holes and counterbores, a single feature control frame is placed under the notes specifying hole and counterbore requirements. See Fig. 7-24. Identical diameter tolerance zones for hole and counterbore are coaxially located (constrained in translation and rotation) at true position relative to the specified datums.

(b) Where different positional tolerances are used to locate holes and counterbores (relative to common datum features), two feature control frames are used. One feature control frame is placed under the note specifying hole requirements and the other under the

**Fig. 7-24 Same Positional Tolerance for Holes and Counterbores, Same Datum References**



Means this



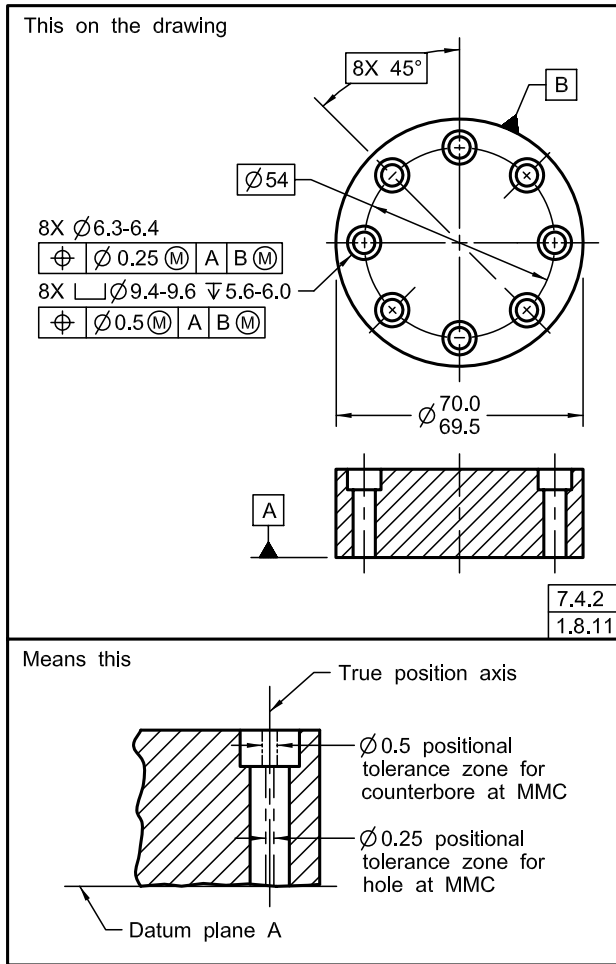
note specifying counterbore requirements. See Fig. 7-25. Different diameter tolerance zones for hole and counterbore are coaxially located at true position relative to the specified datums.

(c) Where positional tolerances are used to locate holes and to control individual counterbore-to-hole relationships (relative to different datum features), two feature control frames are used as in subpara. (b) above. In addition, a note is placed under the datum feature symbol for the hole and under the feature control frame for the counterbore, indicating the number of places each applies on an individual basis. See Fig. 7-26.

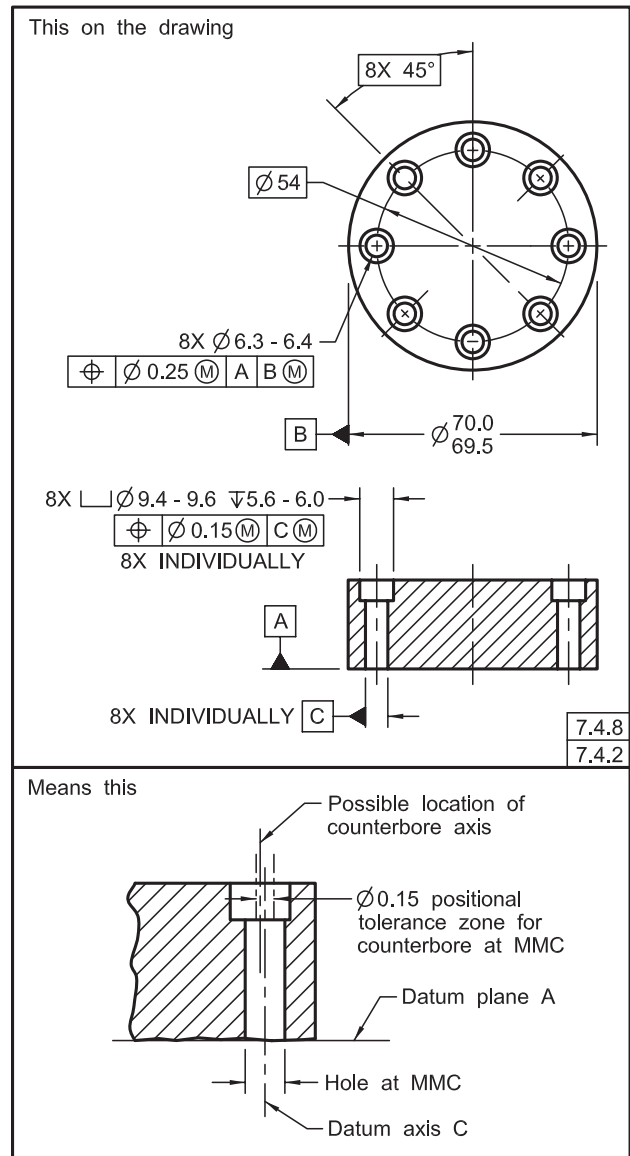
### 7.4.3 Closer Control at One End of a Feature of Size

Where design permits, different positional tolerances may be specified for the extremities of long holes; this establishes a conical rather than a cylindrical tolerance zone. See Fig. 7-27.

**Fig. 7-25 Different Positional Tolerances for Holes and Counterbores, Same Datum References**



**Fig. 7-26 Positional Tolerances for Holes and Counterbores, Different Datum References**



**7.4.4 Bidirectional Positional Tolerancing of Features of Size**

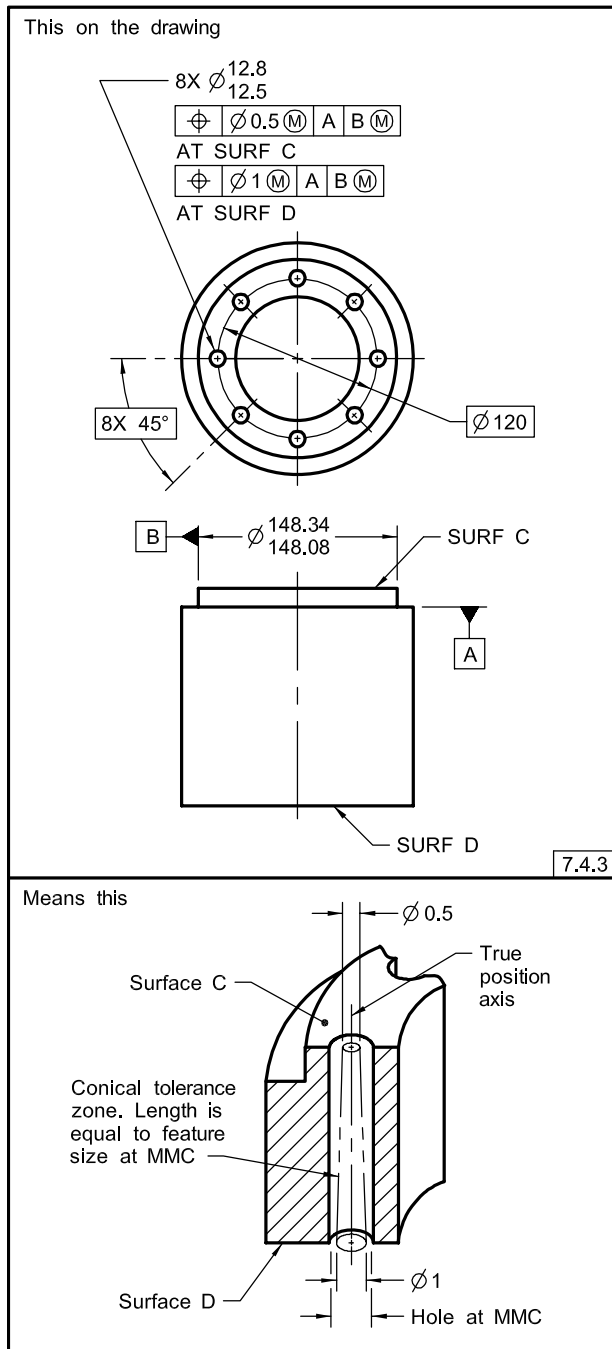
Where it is desired to specify a greater tolerance in one direction than another, bidirectional positional tolerancing may be applied. Bidirectional positional tolerancing results in a noncylindrical tolerance zone for locating round holes; therefore, the diameter symbol is omitted from the feature control frame in these applications.

NOTE: A further refinement of perpendicularity within the positional tolerance may be required.

**7.4.4.1 Rectangular Coordinate Method.** For features located by rectangular coordinate dimensions, separate feature control frames are used to indicate the direction and magnitude of each positional tolerance relative to specified datums. See Fig. 7-28. The feature control frames are attached to dimension lines applied in perpendicular directions. Each tolerance value represents a distance between two parallel planes equally disposed about the true position.

**7.4.4.2 Polar Coordinate Method.** Bidirectional positional tolerancing may also be applied to features located by polar coordinate dimensions relative to specified datums. Where a different tolerance is desired in each direction, one dimension line is applied in a radial direction, and the other perpendicular to the line-of-centers. The positional tolerance values represent distances between two concentric arc boundaries (for the radial direction), and two parallel planes, equally disposed about the true position. See Fig. 7-29. In this example, a further requirement of perpendicularity within the positional tolerance zone has been specified. The example in Fig. 7-29 is typical of a gear center application. In all cases, the shape and extent of the tolerance zone shall be made clear.

**Fig. 7-27 Different Positional Tolerance at Each End of Long Hole**



**7.4.5 Noncircular Features of Size**

The fundamental principles of true position dimensioning and positional tolerancing for circular features of size, such as holes and bosses, apply also to noncircular features of size, such as open-end slots, tabs, and elongated holes. For such features of size, a positional tolerance is used to locate the center plane established by parallel surfaces of the feature of size. The tolerance

value represents a distance between two parallel planes. The diameter symbol is omitted from the feature control frame. See Figs. 7-30 and 7-31.

**7.4.5.1 Noncircular Features of Size at MMC.** Where a positional tolerance of a noncircular feature of size applies at MMC, the following apply.

(a) *In Terms of the Surfaces of an Internal Feature of Size.* While maintaining the specified size limits of the internal feature, no element of the internal feature of size surfaces shall be inside a theoretical boundary located at true position. See Fig. 7-32.

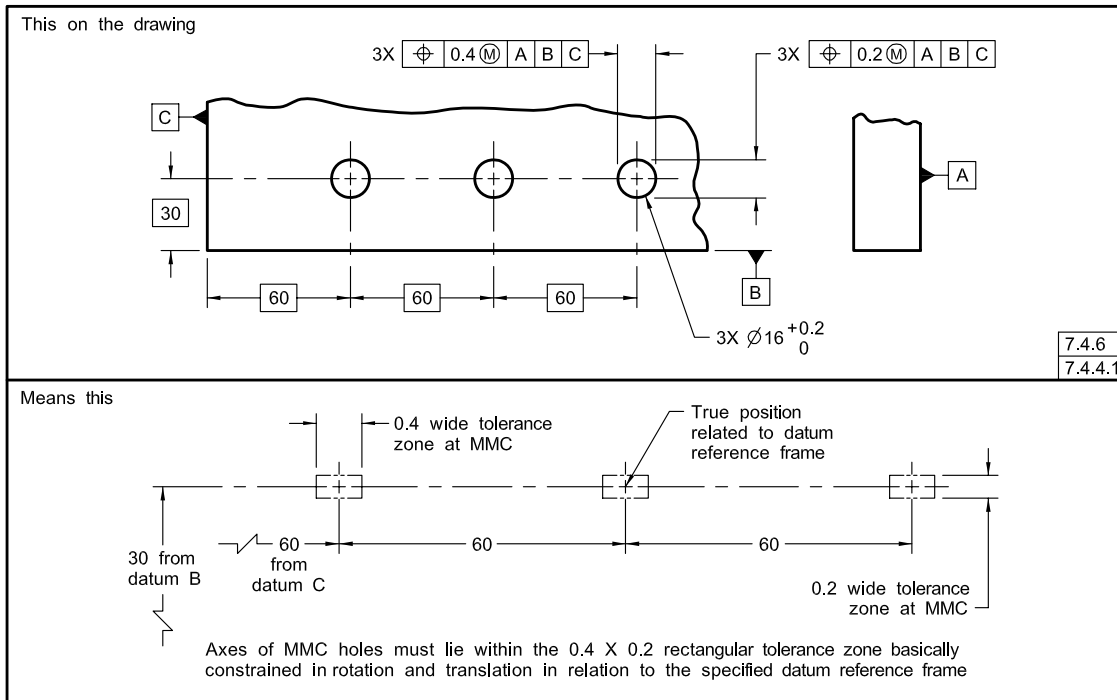
(b) *In Terms of the Center Plane of an Internal Feature of Size.* Where an internal feature of size is at MMC (minimum size), its center plane must fall within a tolerance zone defined by two parallel planes equally disposed about true position. The width of this zone is equal to the positional tolerance. See Fig. 7-33. This tolerance zone also defines the limits of variations in the orientation of the center plane of the internal feature of size in relation to the datum surface. It is only where the internal feature of size is at MMC that the specified tolerance zone applies. Where the unrelated actual mating envelope size of the internal feature of size is larger than MMC, additional positional tolerance results. This increase of positional tolerance is equal to the difference between the specified maximum material condition limit of size (MMC) and the unrelated actual mating envelope size of the internal feature of size. Where the unrelated actual mating envelope size is larger than MMC, the specified positional tolerance for an internal feature of size may be exceeded and still satisfy function and interchangeability requirements.

(c) *In Terms of the Boundary of an Internal Feature of Size.* A positional tolerance applied to a feature of size establishes a control of the surface relative to a boundary. While maintaining the specified size limits of the feature of size, no element of its surface shall violate a theoretical boundary of identical shape located at true position. The size of the boundary is equal to the MMC size of the internal feature of size minus its positional tolerance. See Fig. 7-34. The term **BOUNDARY** may be placed beneath the feature control frames, but is not required. In this example, a greater positional tolerance is allowed for its length than for its width. Where the same positional tolerance can be allowed for both, only one feature control frame is necessary, directed to the feature by a leader and separated from the size dimensions.

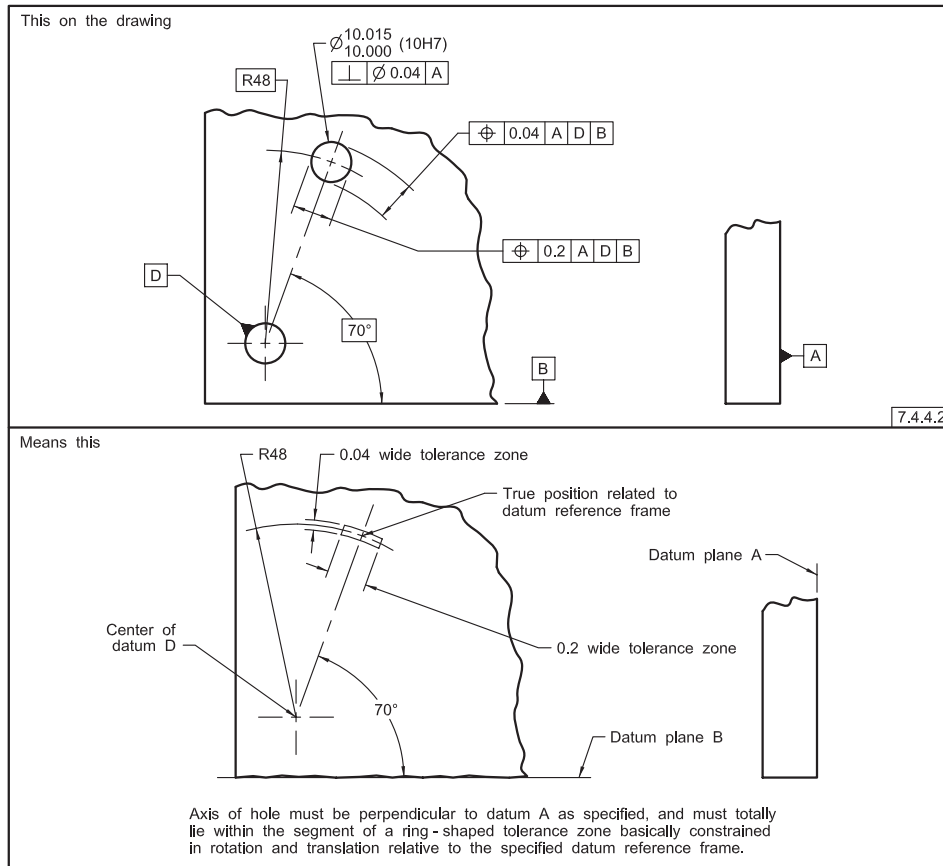
NOTE: This boundary concept can also be applied to other irregular shaped features of size — such as a D-shaped hole (with a flattened side) — where the center is not conveniently identifiable. See para. 8.8.

**7.4.5.2 LMC Applied to a Radial Pattern of Slots.** In Fig. 7-16, a radial pattern of slots is located relative to an end face and a center hole. LMC is specified to

**Fig. 7-28 Bidirectional Positional Tolerancing, Rectangular Coordinate Method**

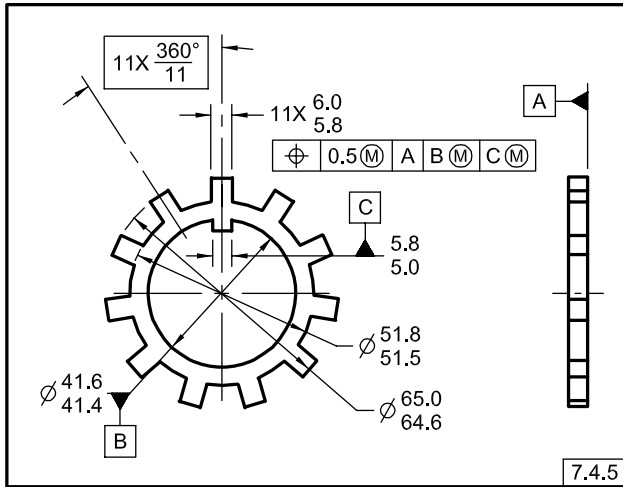


**Fig. 7-29 Bidirectional Positional Tolerancing, Polar Coordinate Method**

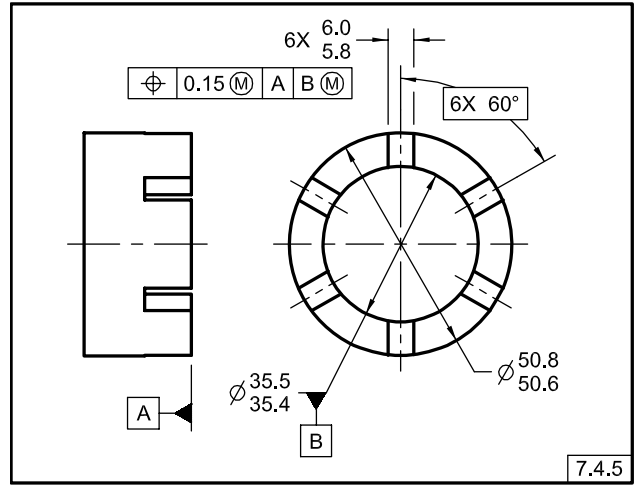




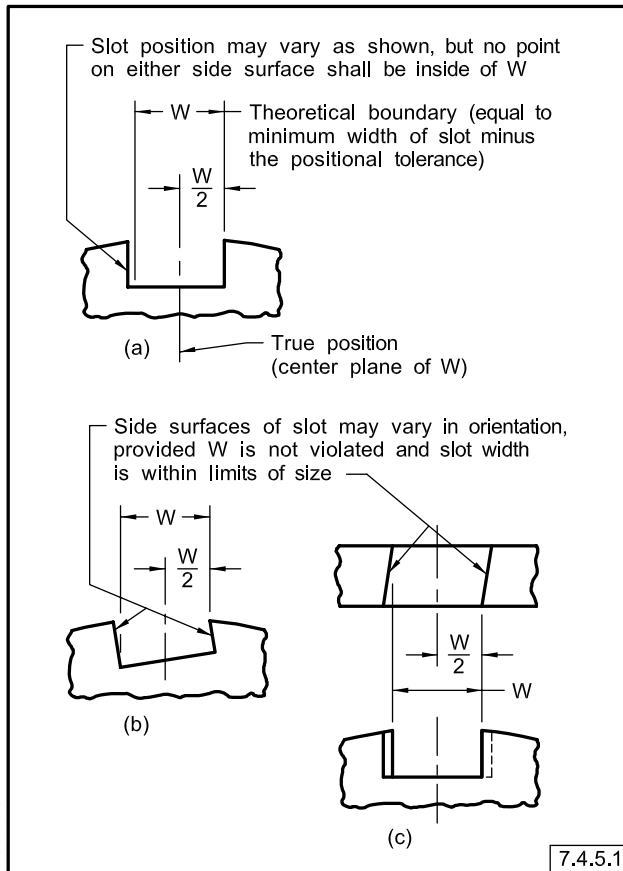
**Fig. 7-30 Positional Tolerancing of Tabs**



**Fig. 7-31 Positional Tolerancing of Slots**



**Fig. 7-32 Virtual Condition for Surfaces of Slot at MMC**



**Fig. 7-33 Tolerance Zone for Center Plane of Slot at MMC**

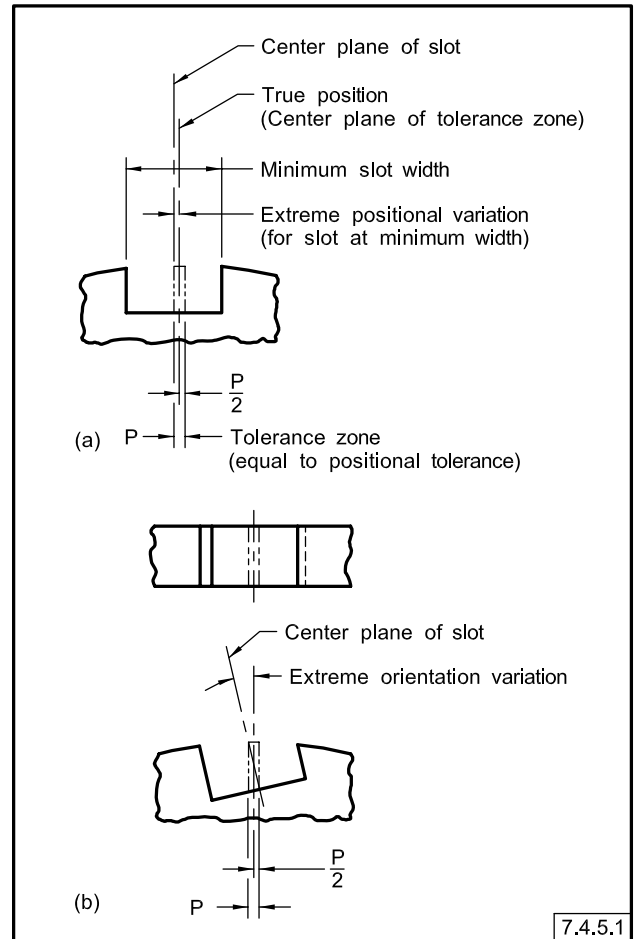
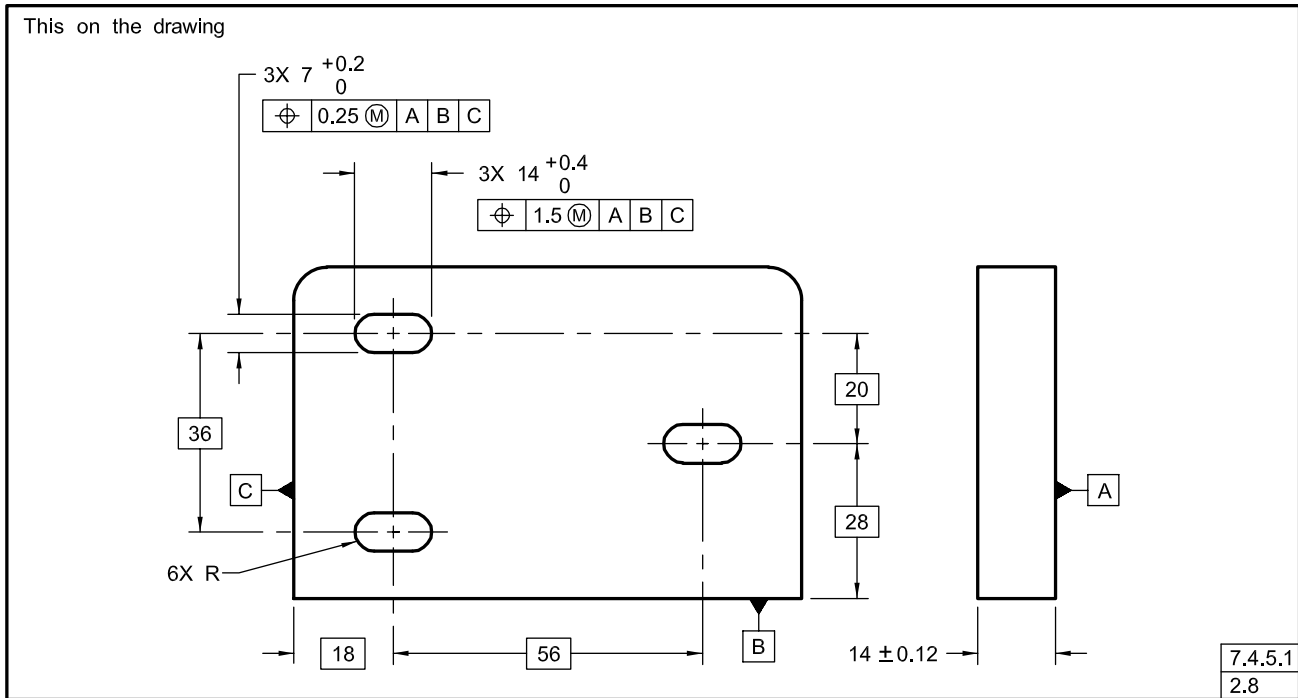
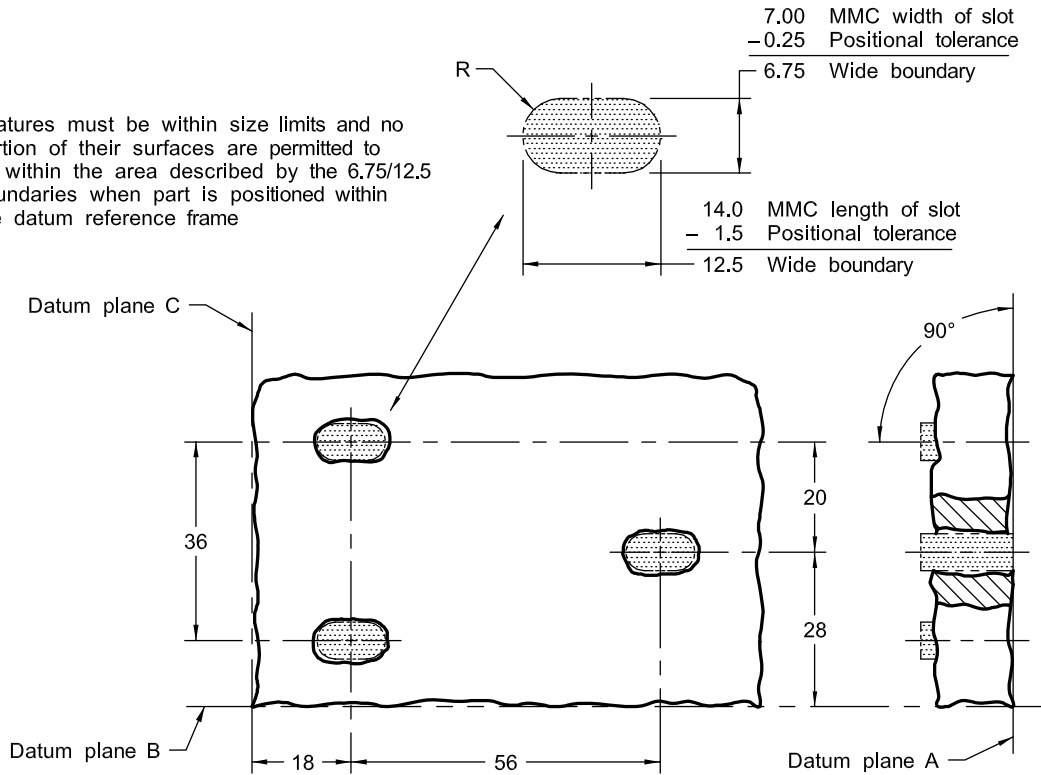


Fig. 7-34 Positional Tolerancing, Boundary Concept

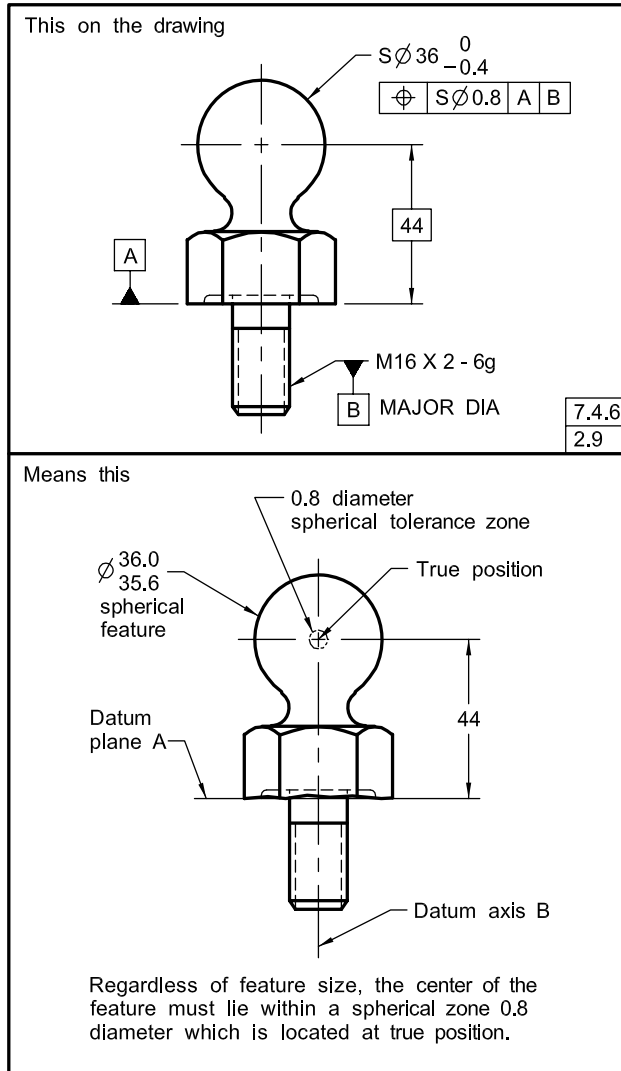


Means this

Features must be within size limits and no portion of their surfaces are permitted to lie within the area described by the 6.75/12.5 boundaries when part is positioned within the datum reference frame



**Fig. 7-35 Spherical Feature Located by Positional Tolerancing**



maintain the desired relationship between the side surfaces of the slots and the true position, where rotational alignment with the mating part may be critical.

### 7.4.6 Spherical Features

A positional tolerance may be used to control the location of a spherical feature relative to other features of a part. See Fig. 7-35. The symbol for spherical diameter precedes the size dimension of the feature and the positional tolerance value, to indicate a spherical tolerance zone. Where it is intended for the tolerance zone shape to be otherwise, a special indication is shown, similar to the example shown for a bidirectional tolerance zone of a cylindrical hole. See Fig. 7-28.

### 7.4.7 Nonparallel Axis Hole Patterns

Positional tolerancing may be applied to a pattern of holes where axes are not parallel to each other and where axes are not normal to the surface. See Fig. 7-36.

### 7.4.8 Repetitive Pattern of Features of Size Related to a Repeated Datum Reference Frame

Where positional tolerances are used to locate patterns of features of size relative to repetitive datums, the feature control frames and datums are specified as shown in Figs. 7-26 and 7-37. A note is placed beneath or adjacent to the datum feature symbol and another beneath or adjacent to the feature control frame for the controlled features of size indicating the number of places each applies on an individual basis. To establish association with one line of a multiple segment feature control frame, placement shall be adjacent to the applicable segment. Should the individual requirements be shown on the main view or in a CAD model without a detail view, the indication of the number of occurrences shall be shown. Figure 7-37 shows the application of individual requirements in a detail view. When a detail view includes a notation of the number of occurrences of that detail view, then the 6X on the INDIVIDUALLY notation may be omitted. The 6X INDIVIDUALLY notation beside the datum feature D symbol indicates that each of the six occurrences of the 79.4-diameter hole acts as a separate datum feature and establishes a separate datum D. The 6X INDIVIDUALLY notation associated with the second segment of the positional tolerances on the 4X 3.6-diameter holes indicates that each pattern of four holes has a tolerance zone framework that is located relative to the specified datums.

## 7.5 PATTERN LOCATION

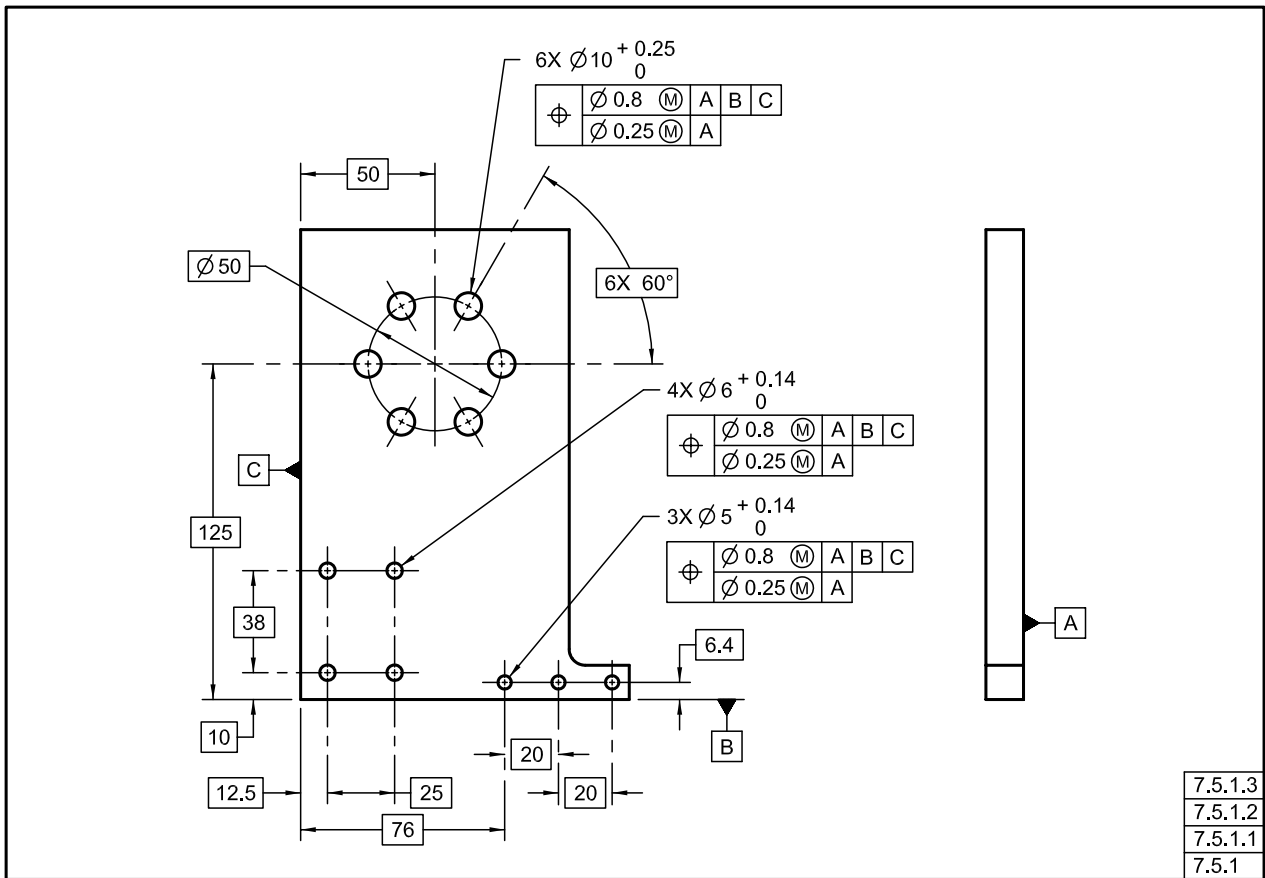
A pattern of features of size may have multiple levels of positional control required. The pattern of features of size may require a larger tolerance relative to the datum reference frame while a smaller tolerance is required within the pattern. Multiple levels of tolerance control may be applied using composite positional tolerances or multiple single segment feature control frames.

### 7.5.1 Composite Positional Tolerancing

Composite positional tolerancing provides an application of positional tolerancing for the location of feature of size patterns as well as the interrelation (constrained in rotation and translation) of features of size within these patterns. Requirements are annotated by the use of a composite feature control frame. See para. 3.4.4 and Fig. 3-26, illustration (a). The position symbol is entered



Fig. 7-38 Hole Patterns Located by Composite Positional Tolerancing



once and is applicable to all horizontal segments. Each complete horizontal segment in the feature control frames of Figs. 7-38 and 7-39 may be verified separately.

(a) *Pattern-Locating Tolerance Zone Framework (PLTZF)*. (The acronym is pronounced "Plahtz.") Where composite controls are used, the uppermost segment is the pattern-locating control. The PLTZF is constrained in rotation and translation relative to the specified datums. It specifies the larger positional tolerance for the location of the pattern of features of size as a group. Applicable datum features are referenced in a desired order of precedence, and serve to relate the PLTZF to the datum reference frame. See Fig. 7-38, illustration (a).

(b) *Feature-Relating Tolerance Zone Framework (FRTZF)*. (The acronym is pronounced "Fritz.") Each lower segment is a feature-relating control. They govern the smaller positional tolerance for each feature of size within the pattern (feature-to-feature relationship). Basic dimensions used to relate the PLTZF to specified datums are not applicable to the location of the FRTZF. See Fig. 7-38, illustration (b).

(1) Where datum references are not specified in a lower segment of the composite feature control frame, the FRTZF is free to rotate and translate within the boundaries established and governed by the PLTZF.

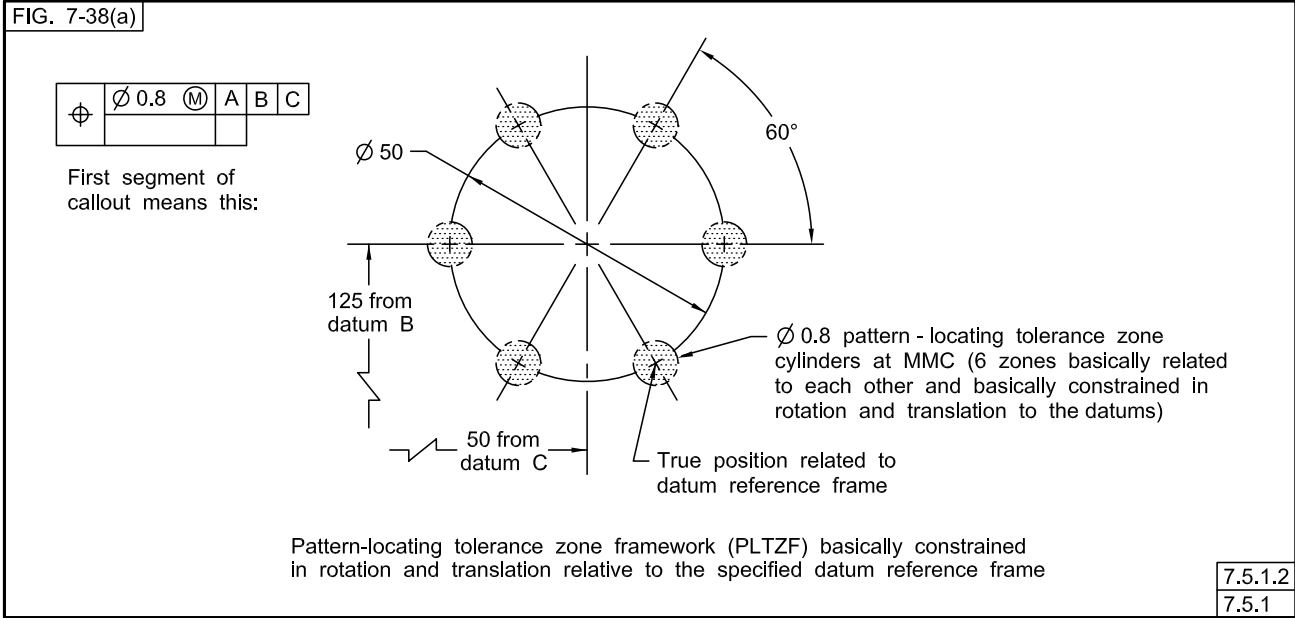
(2) If datums are specified in a lower segment, they govern the rotation of the FRTZF relative to the datums and within the boundaries established and governed by the PLTZF.

(3) Where datum feature references are specified, one or more of the datum feature references specified in the upper segment of the frame are repeated, as applicable, and in the same order of precedence, to constrain rotation of the FRTZF. In some instances the repeated datum feature references may not constrain any degrees of freedom; however, they are necessary to maintain the identical datum reference frame, such as datum feature B in the lower segment in Fig. 7-42.

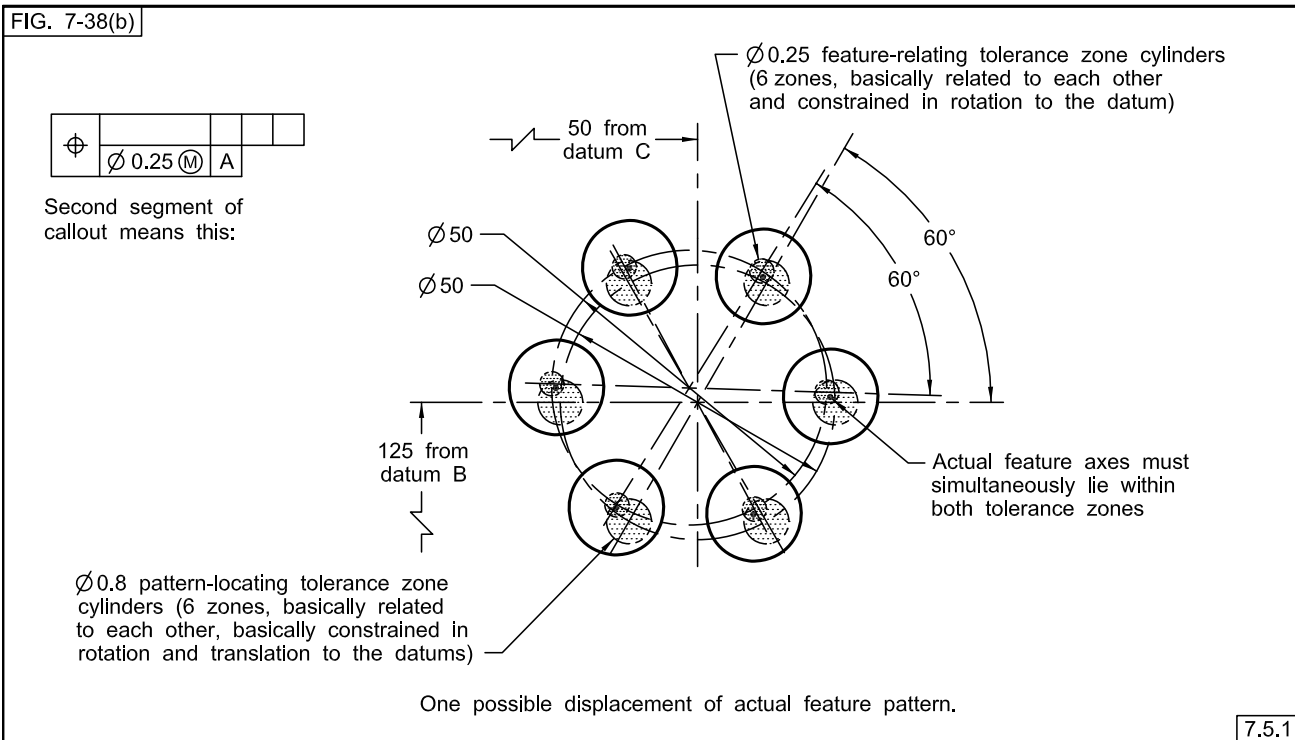
**7.5.1.1 Primary Datum Repeated in Lower Segment.**

As can be seen from the sectional view of the tolerance zones in Fig. 7-38, illustration (c), since datum plane A has been repeated in the lower segment of the composite feature control frame, the axes of both the PLTZF and FRTZF cylinders are perpendicular to datum plane A and therefore parallel to each other. In certain instances, portions of the smaller zones may fall beyond the peripheries of the larger tolerance zones. However, these portions of the smaller tolerance zones are not usable because the axes of the features must not violate

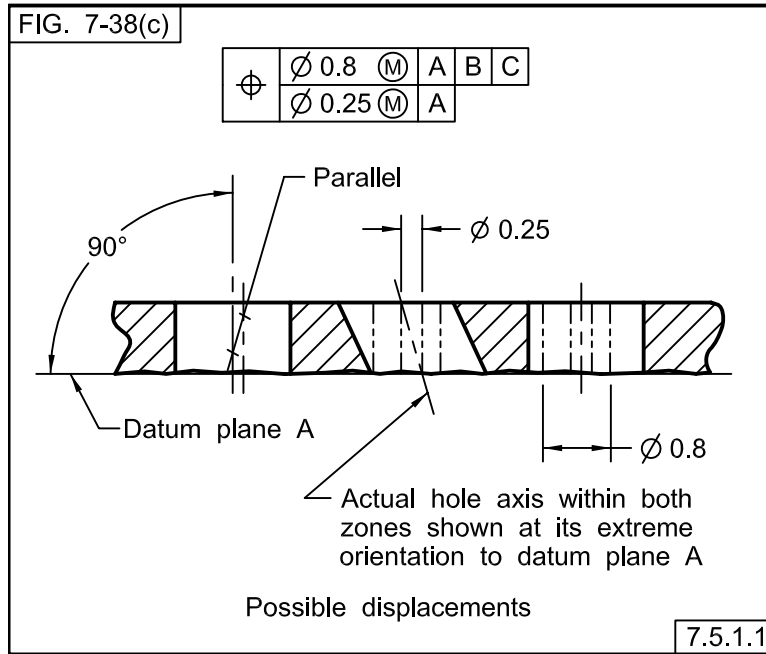
**Fig. 7-38 Hole Patterns Located by Composite Positional Tolerancing (Cont'd)  
(Pattern Locating Tolerance Zone Framework – PLTZF)**



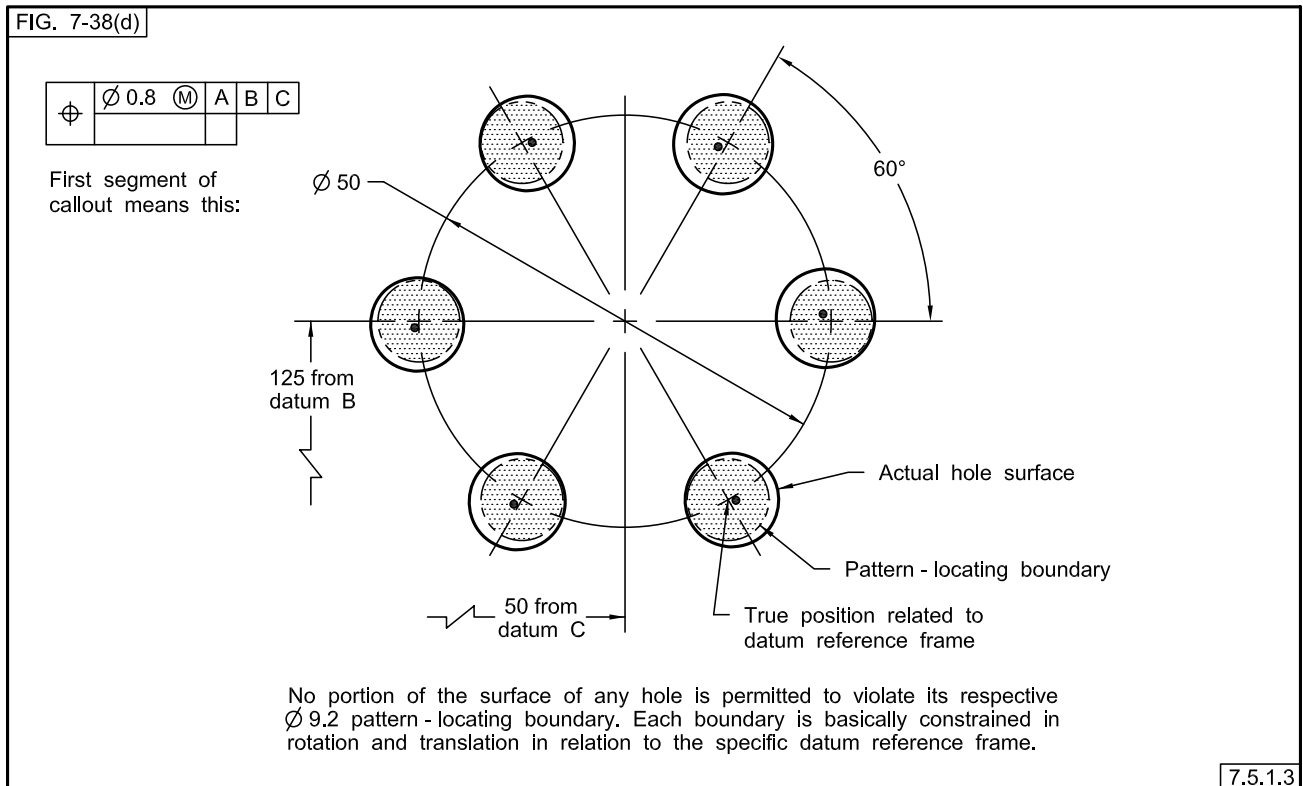
**Fig. 7-38 Hole Patterns Located by Composite Positional Tolerancing (Cont'd)  
(Pattern Locating Tolerance Zone Framework – PLTZF)**



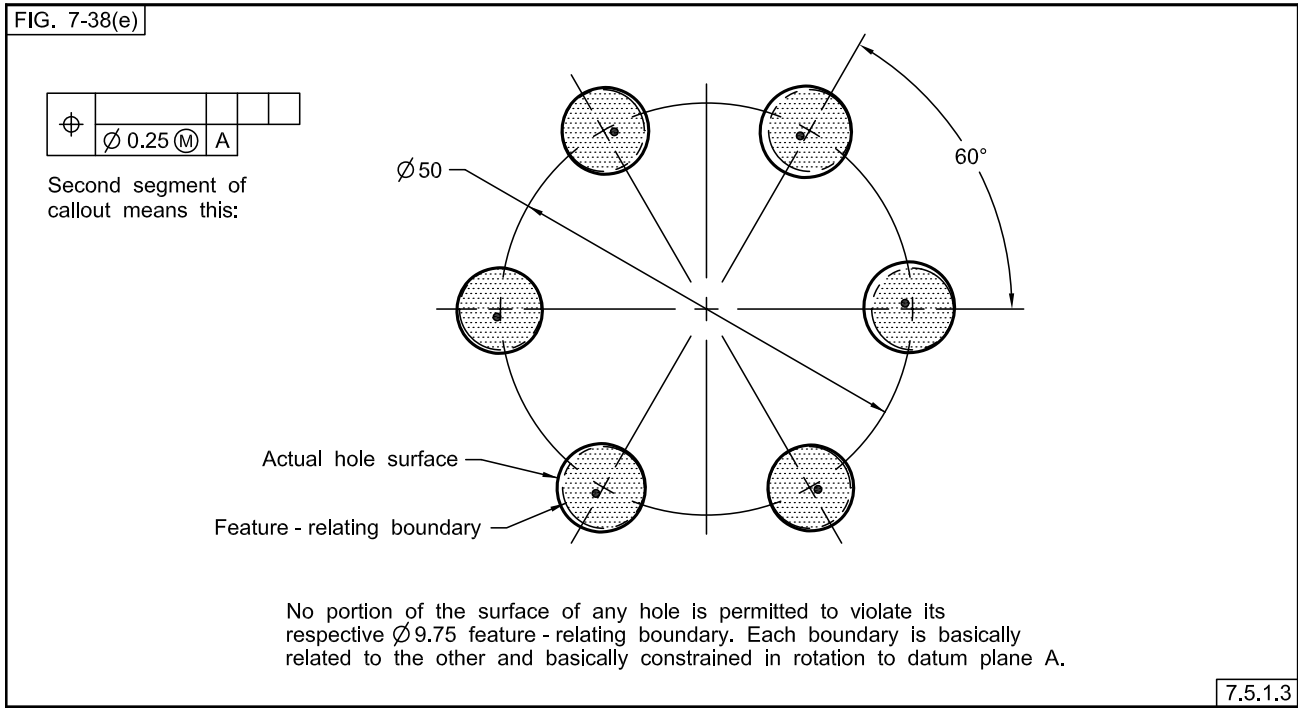
**Fig. 7-38 Hole Patterns Located by Composite Positional Tolerancing (Cont'd)**  
**(Tolerance Zones for Hole Pattern)**



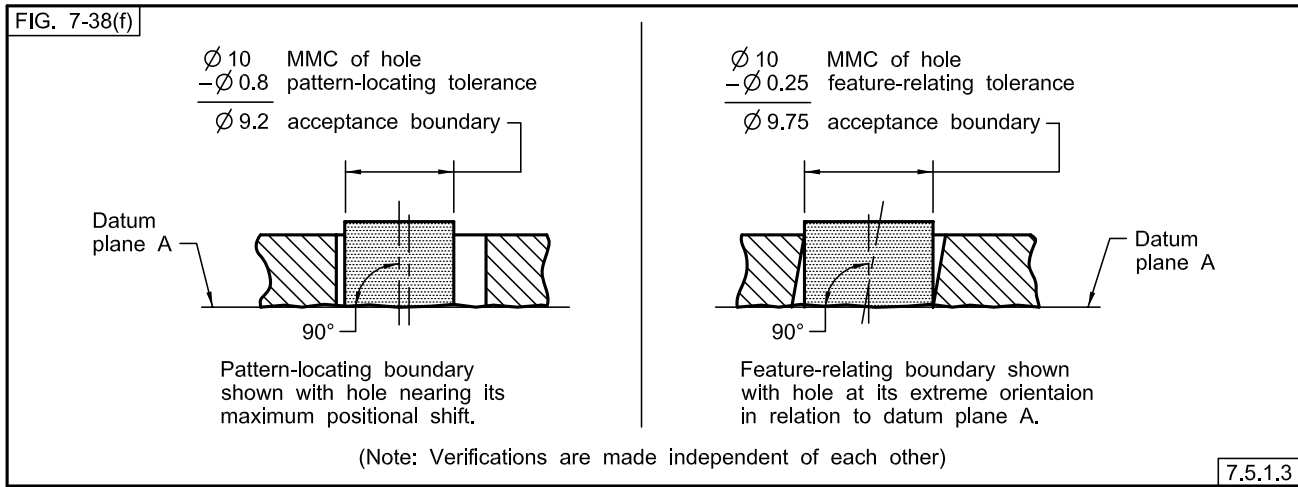
**Fig. 7-38 Hole Patterns Located by Composite Positional Tolerancing (Cont'd)**  
**(Pattern Locating Tolerance Zone Framework – PLTZF)**



**Fig. 7-38 Hole Patterns Located by Composite Positional Tolerancing (Cont'd)  
(Feature-Relating Tolerance Zone Framework – FRTZF)**



**Fig. 7-38 Hole Patterns Located by Composite Positional Tolerancing (Cont'd)  
(Acceptance Boundaries for Holes in Pattern)**



the boundaries of the larger tolerance zones. The axes of the holes must lie within the larger tolerance zones and within the smaller tolerance zones. The axes of the actual holes may vary obliquely (out of perpendicularity) only within the confines of the respective smaller positional tolerance zones (FRTZF).

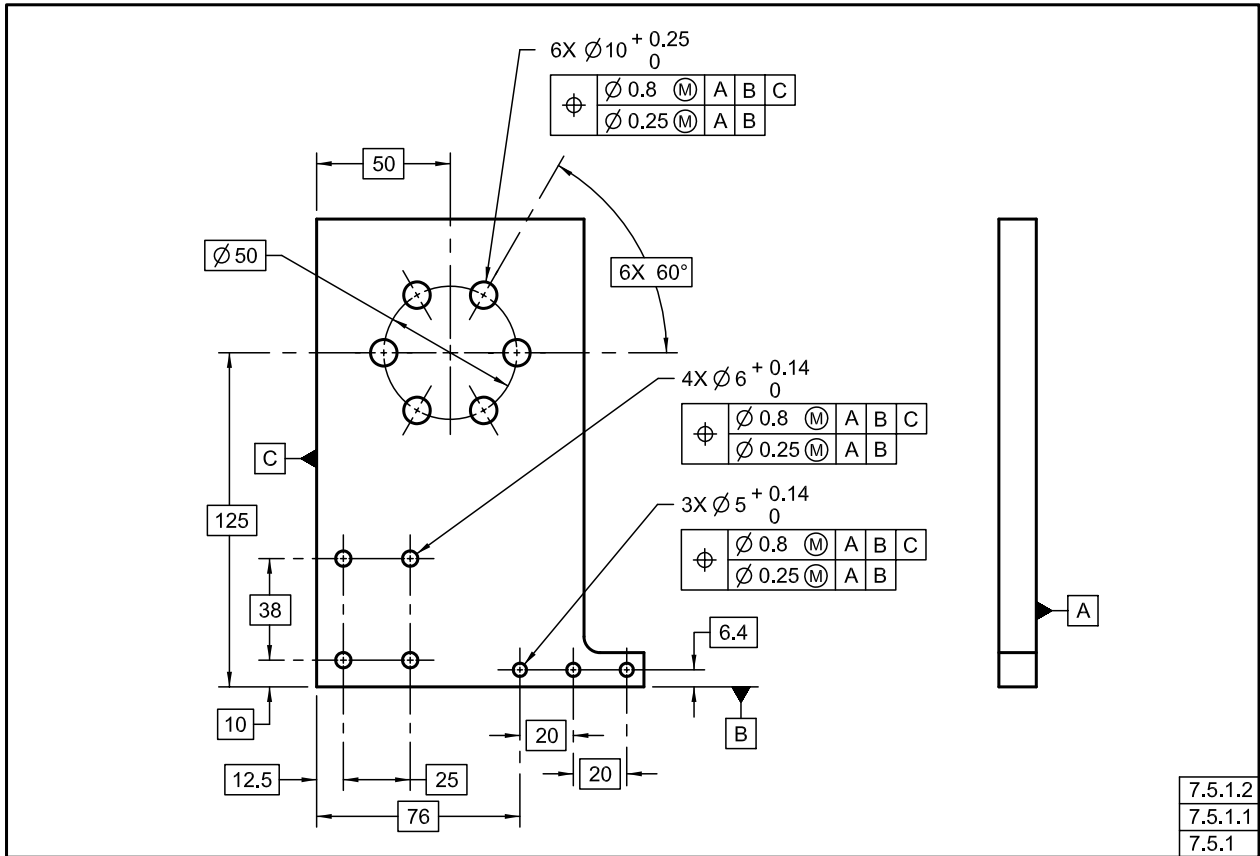
NOTE: The zones in Figs. 7-38 and 7-39 are shown as they exist at MMC of the features. The large zones would increase in size by

the amount the features depart from MMC, as would the smaller zones; the two zones are not cumulative.

**7.5.1.2 Primary and Secondary Datums Repeated in Lower Segment.** Figure 7-39 repeats the hole patterns of Fig. 7-38. In Fig. 7-39, the lower segment of the composite feature control frame repeats datums A and B. The pattern-locating tolerance requirements established by



**Fig. 7-39 Hole Patterns of Fig. 7-38 With Secondary Datums in Feature-Relating Segments of Composite Feature Control Frames**



**Fig. 7-39 Hole Patterns for Fig. 7-39 With Secondary Datums in Feature-Relating Segments of Composite Feature Control Frames (Cont'd) (Tolerance Zones for Six-Hole Pattern)**

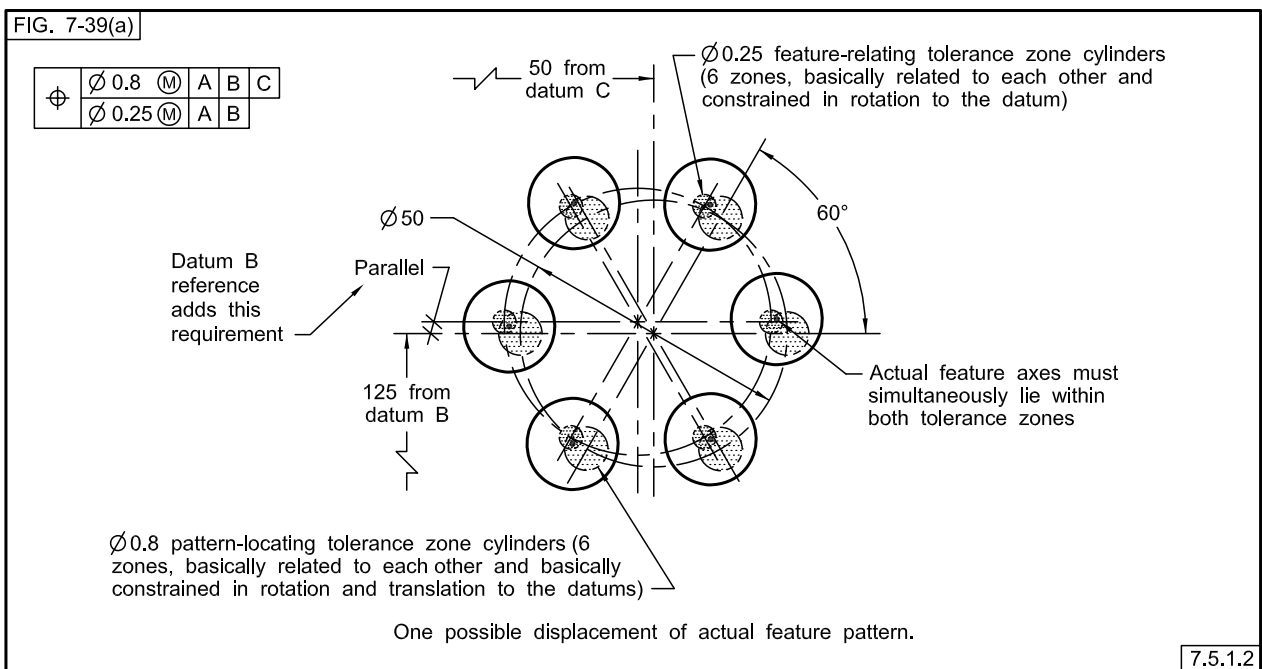


Fig. 7-40 Composite Positional Tolerancing of a Circular Pattern of Features

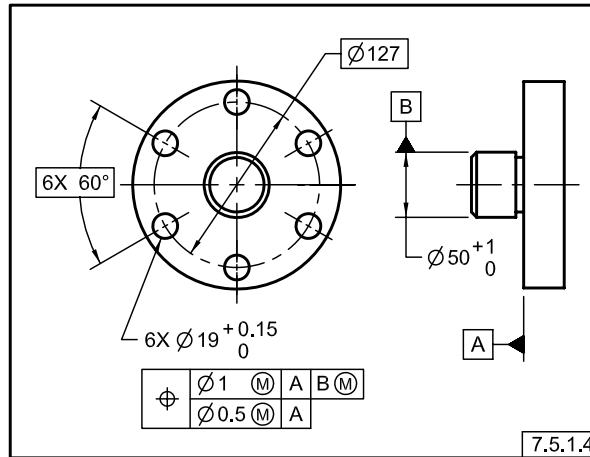
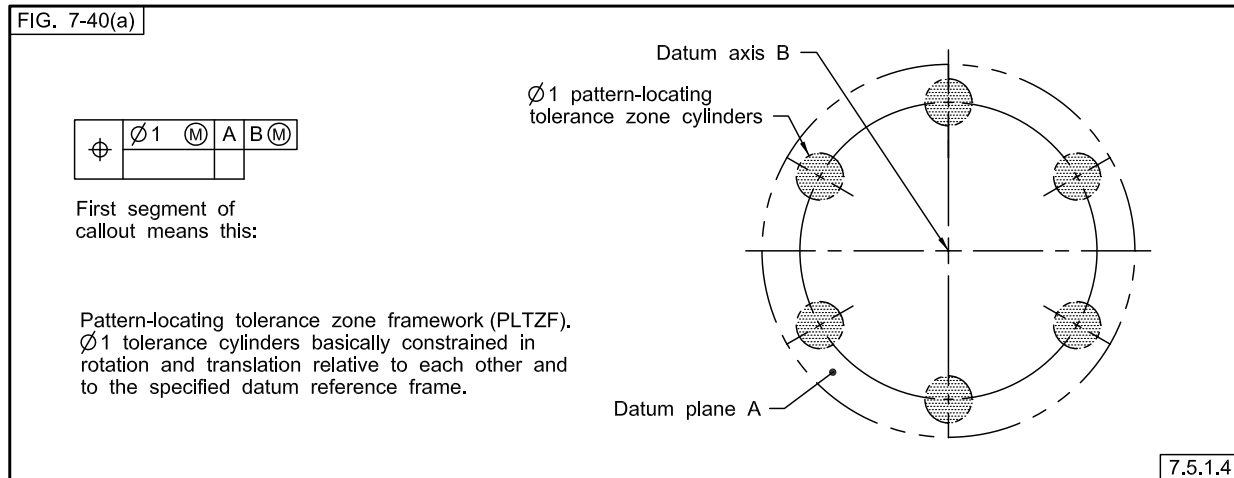


Fig. 7-40 Composite Positional Tolerancing of a Circular Pattern of Features (Cont'd)



the first segment are the same as explained in Fig. 7-38. Figure 7-38, illustration (a) shows that the tolerance cylinders of the FRTZF may be translated (displaced) from the true position locations (as a group) as governed by the tolerance cylinders of the PLTZF, while constrained in rotation to datum planes A and B. Figure 7-39, illustration (a) shows that the actual axes of the holes in the actual feature pattern must reside within both the tolerance cylinders of the FRTZF and the PLTZF.

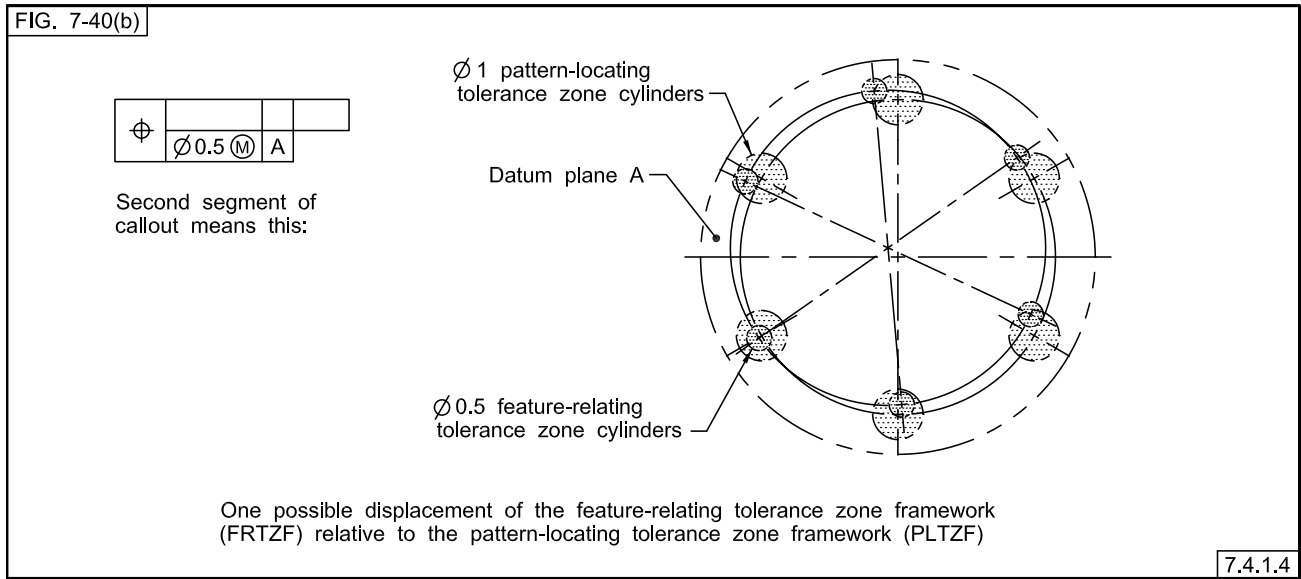
**7.5.1.3 In Terms of Hole Surfaces.** Figure 7-38, illustrations (d) through (f) illustrate the positional tolerance requirements of the six-hole pattern of Fig. 7-38, and is explained in terms of hole surfaces relative to acceptance boundaries. See para. 7.3.3.1(a). The result is the same for the surface explanation as for an axis, except as noted in para. 7.3.3.1.

**7.5.1.4 Applied to Patterns of Features of Size Relative to Datum Features.** Composite positional tolerancing

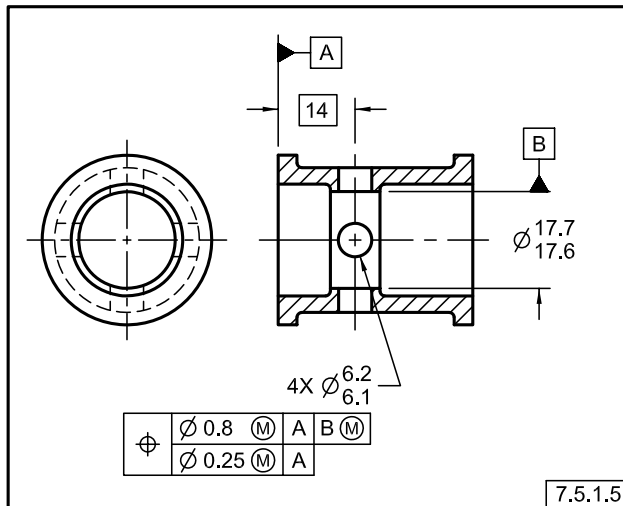
may be applied to patterns of features of size on circular parts. See Figs. 7-40 and 7-40, illustration (a). With datum A repeated in the lower segment of the composite feature control frame, Fig. 7-40, illustration (b) shows the tolerance cylinders of the FRTZF translated (as a group) from the basic locations within the bounds imposed by the PLTZF, while constrained in rotation to datum plane A.

**7.5.1.5 Radial Hole Pattern.** Figure 7-41 shows an example of a radial hole pattern where the plane of the PLTZF is located from a datum face by a basic dimension. Where datum references are not specified in the lower segment of a composite feature control frame, the FRTZF is free to rotate and translate as governed by the tolerance zones of the PLTZF. The same explanation given in para. 7.5.1 also applies to Fig. 7-41. With datum plane A referenced in the lower segment of the composite feature control frame, the tolerance zones of the FRTZF (as a group) are constrained in rotation (parallel to datum plane A) and may be translated as governed

**Fig. 7-40 Composite Positional Tolerancing of a Circular Pattern of Features (Cont'd)**



**Fig. 7-41 Radial Hole Pattern Located by Composite Positional Tolerancing**



by the tolerance zones of the PLTZF. See also Fig. 7-41, illustrations (a) through (d).

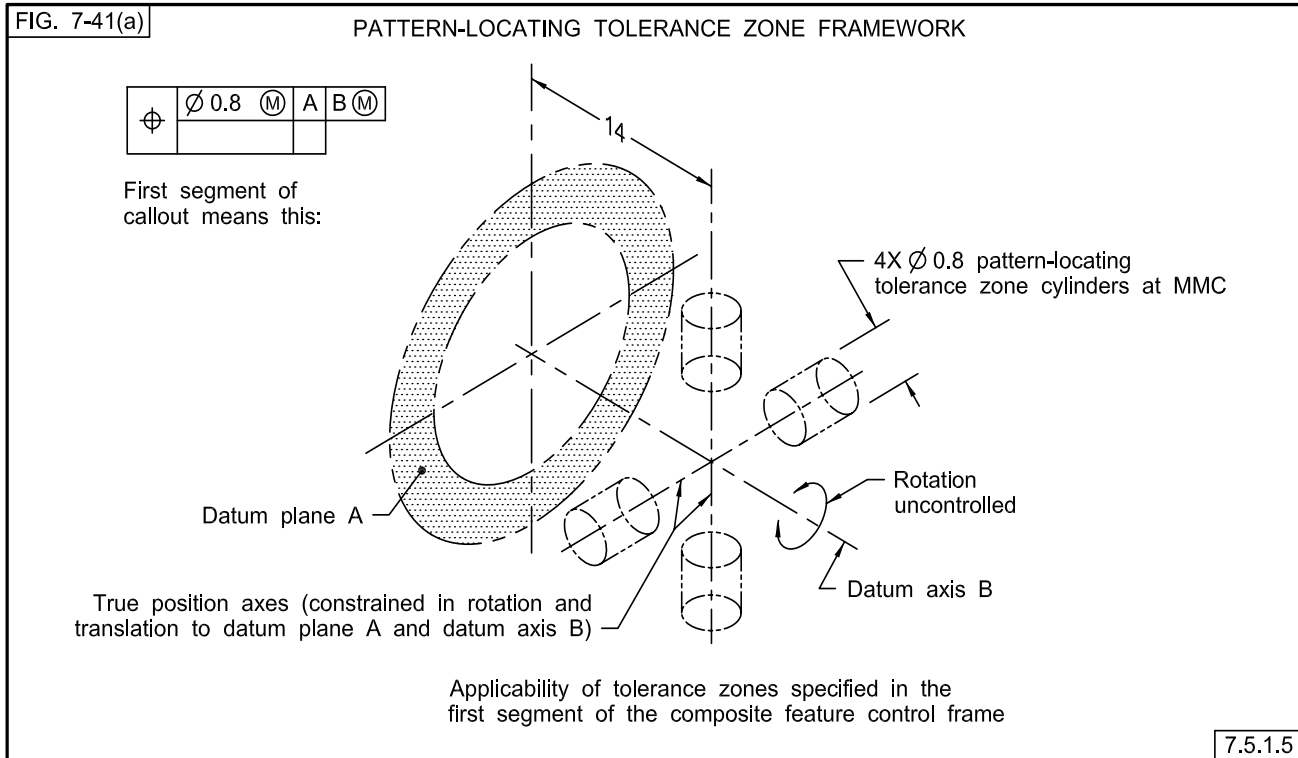
**7.5.1.6 Where Radial Location is Important.** The control shown in Figs. 7-42 and 7-43 may be specified where rotational constraint is important. The design, however, permits a feature-relating tolerance zone to be displaced within the bounds governed by a pattern-locating tolerance zone, while held parallel and perpendicular to the three mutually perpendicular planes of

the datum reference frame. See also Fig. 7-42, illustrations (a) and (b).

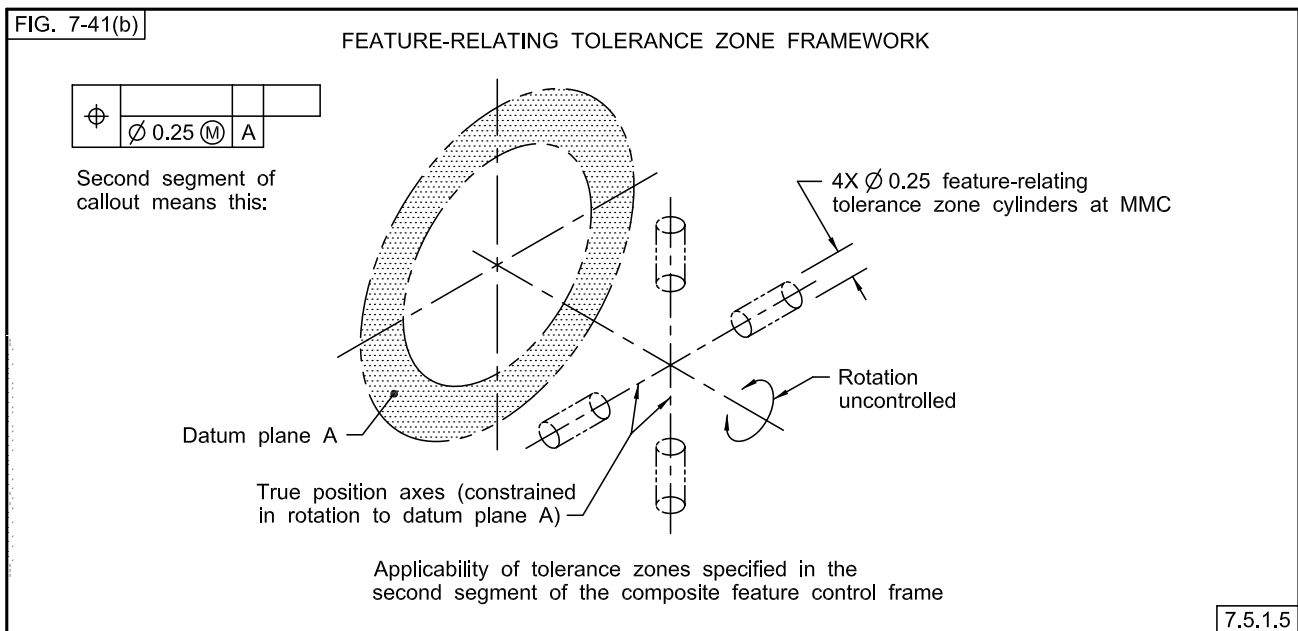
**7.5.1.7 Projected Tolerance Zones for Composite Positional Tolerancing.** Where the design dictates the use of a projected tolerance zone for composite positional tolerancing, the projected tolerance zone symbol is placed in the applicable segment(s) of the composite feature control frame as required. The projected tolerance zone applies only to the segment in which the symbol is shown. Where a projected tolerance zone is specified, the feature axes shall simultaneously lie within both the pattern and feature locating tolerance zones.

**7.5.1.8 Composite Positional Tolerances: Multiple Segments.** Composite tolerances have two or more segments. Each segment establishes tolerance zones and constraints to any referenced datums shown in the segment. Datum references in the first segment establish all applicable rotational and translational constraints relative to the referenced datums. Datum references in the second and subsequent segments establish only rotational constraints relative to the referenced datums. See Fig. 7-44. Absence of datum references in a segment indicate that no rotational or translation constraints are established by that segment. For a pattern of features with a composite positional tolerance applied, a PLTZF is created by the first segment, and a separate FRTZF is created by each of the subsequent segments. Each FRTZF is constrained only to the referenced datums within the segment. See Fig. 7-45. The first segment of the given

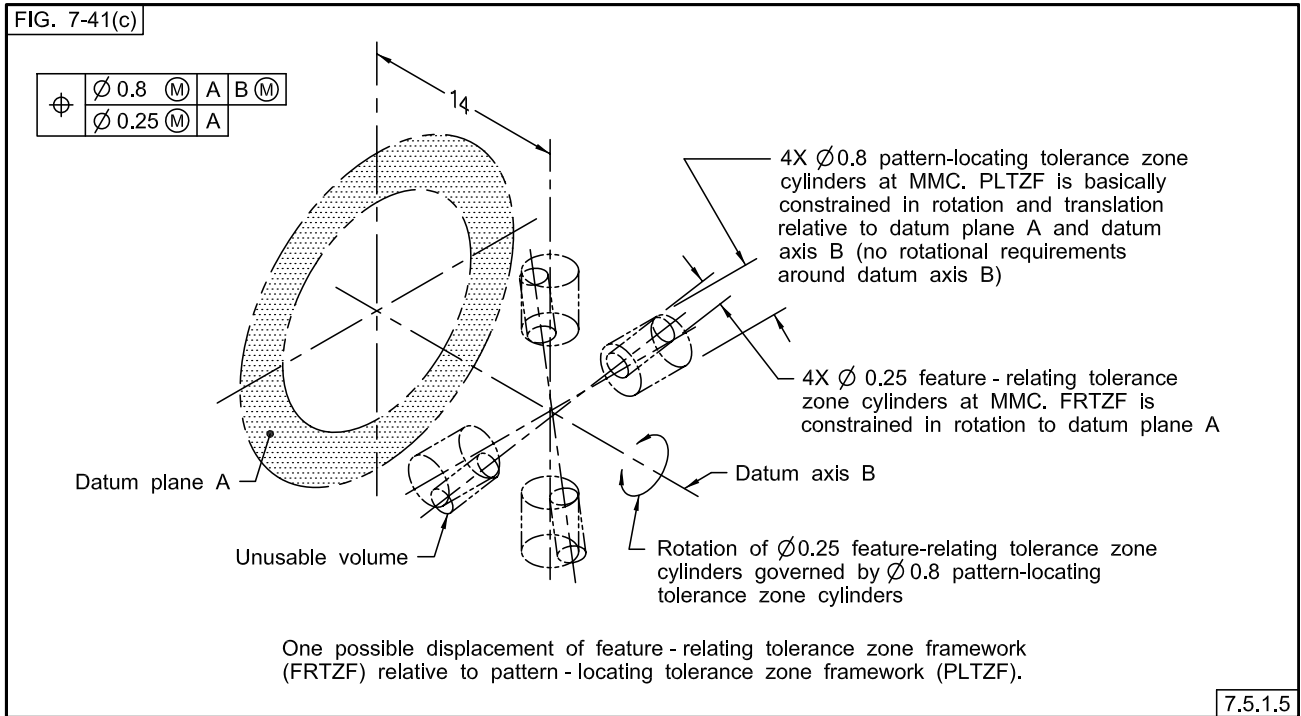
**Fig. 7-41 Radial Hole Pattern Located by Composite Positional Tolerancing (Cont'd)**  
**(Tolerance Zones for Radial Hole Pattern)**



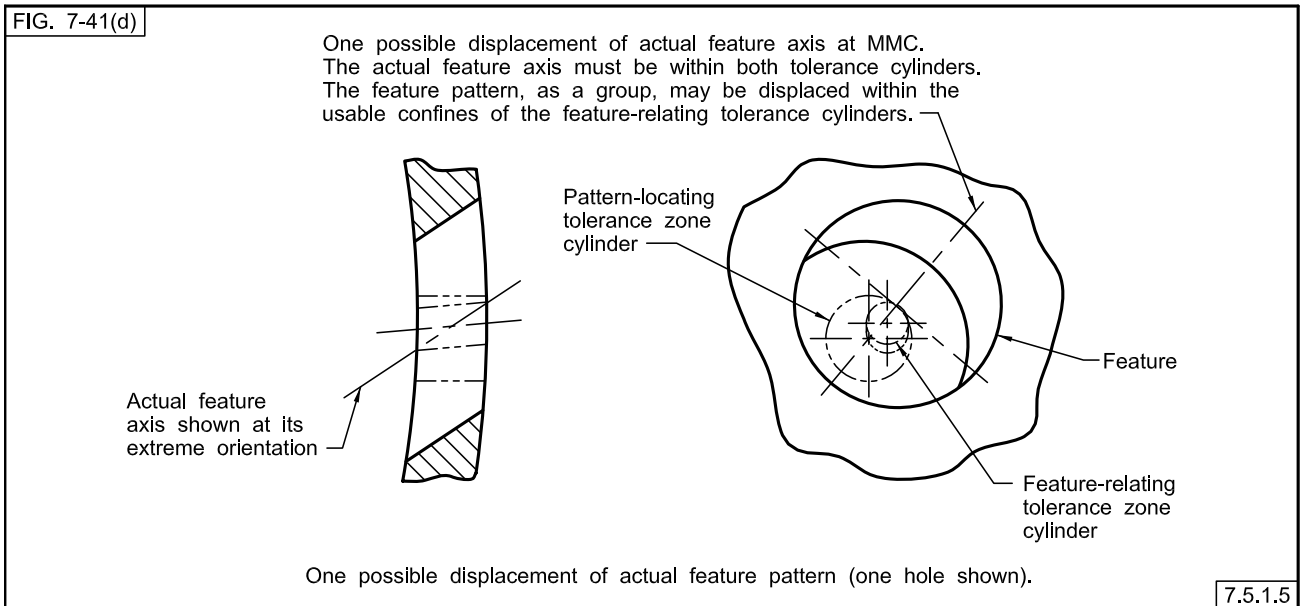
**Fig. 7-41 Radial Hole Pattern Located by Composite Positional Tolerancing (Cont'd)**  
**(Tolerance Zones for Radial Hole Pattern)**



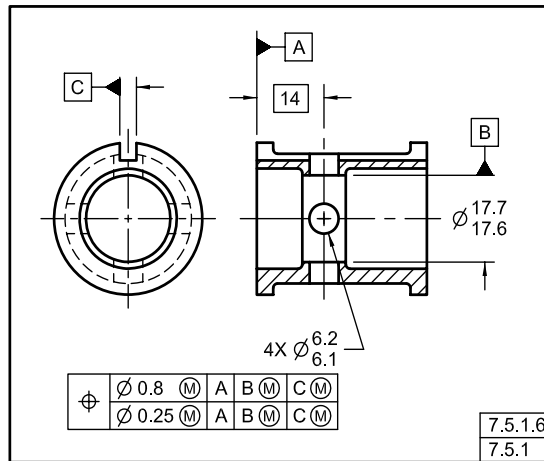
**Fig. 7-41 Radial Hole Pattern Located by Composite Positional Tolerancing (Cont'd)  
(Tolerance Zones for Radial Hole Pattern)**



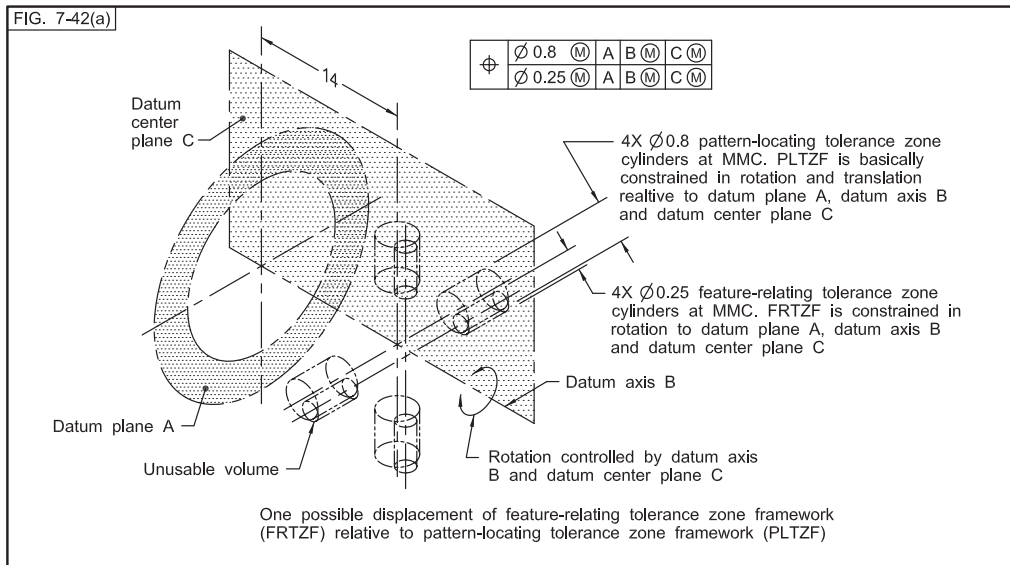
**Fig. 7-41 Radial Hole Pattern Located by Composite Positional Tolerancing (Cont'd)  
(Tolerance Zones for Radial Hole Pattern)**



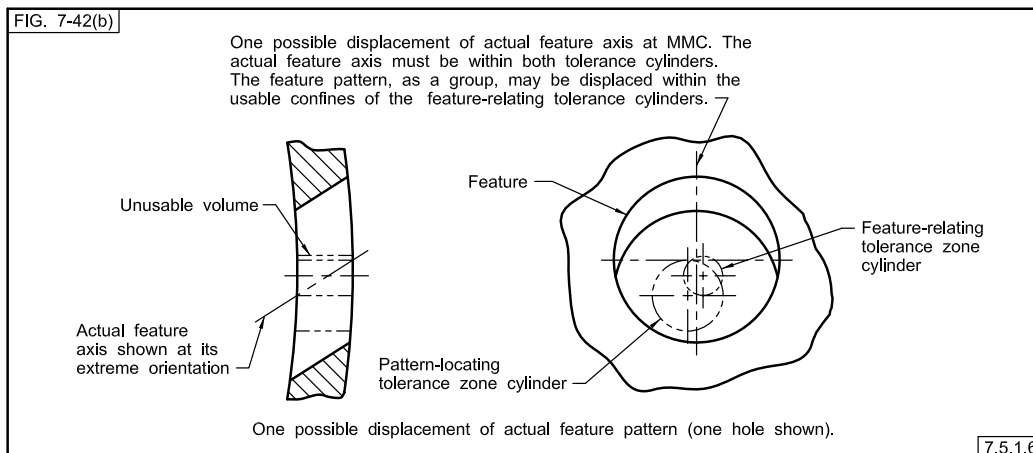
**Fig. 7-42 Radial Hole Pattern Located by Composite Positional Tolerancing**



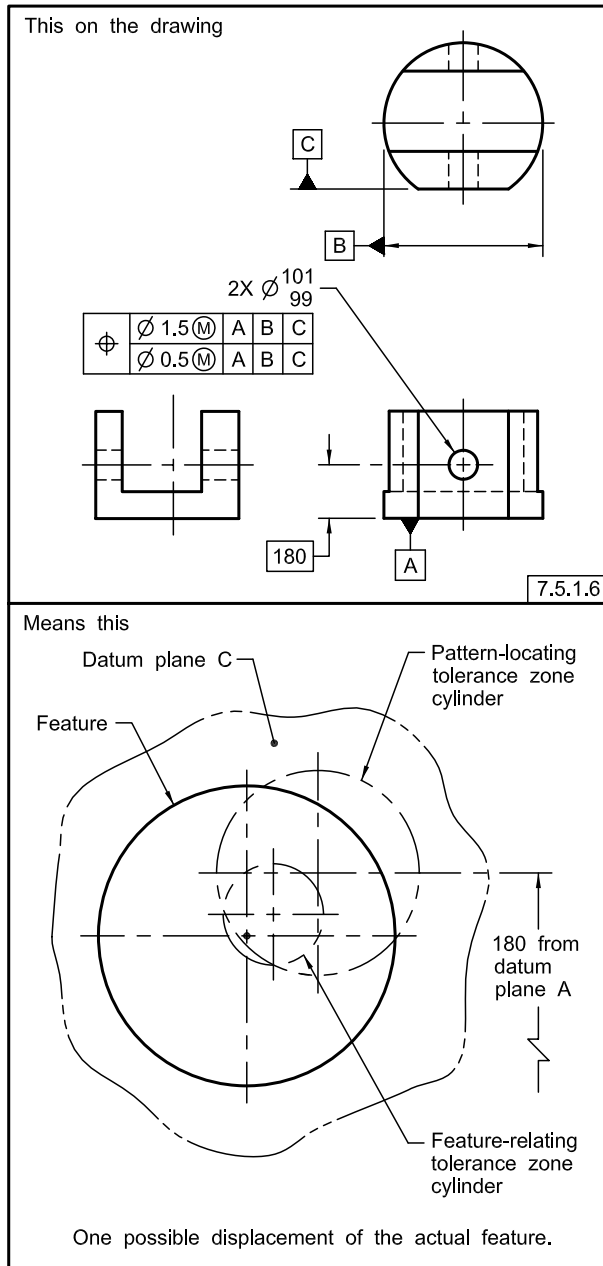
**Fig. 7-42 Radial Hole Pattern Located by Composite Positional Tolerancing (Cont'd) (Tolerance Zones for Radial Hole Pattern)**



**Fig. 7-42 Radial Hole Pattern Located by Composite Positional Tolerancing (Cont'd) (Tolerance Zones for Radial Hole Pattern)**



**Fig. 7-43 Orientation Relative to Three Datum Planes**



example creates a PLTZF that is a straight segment with two 0.5-diameter tolerance zones (at MMC) constrained in rotation and translation relative to datums A, B and C at MMB, and C at MMB. The second segment creates a FRTZF that is a straight segment with two 0.12-diameter tolerance zones (at MMC) that are constrained in rotation relative to datum A. The third segment creates a FRTZF that is a straight segment with two 0.07-diameter tolerance zones (at MMC) with no constraint to any datum.

**7.5.2 Multiple Single-Segment Positional Tolerancing**

Multiple single-segment positional tolerances provide multiple positional tolerancing requirements for the location of features of size and establishes requirements for pattern location as well as the interrelation (constrained in rotation and translation) of features of size within the patterns. Requirements are annotated by the use of two or more feature control frames. The position symbol is entered in each of the single segments. The datum feature references in any segment are not permitted to be an exact repeat of all the datum feature references in other segments. Each complete horizontal segment is verified separately. Where multiple single-segment positional controls are used, each segment creates a tolerance zone framework. It is neither a PLTZF nor FRTZF, since those terms are specific to composite tolerances. Applicable datum feature references are specified in a desired order of precedence and serve to relate the tolerance zone framework to the datum reference frame. See Figs. 3-26, illustration (b); 7-46; 7-47; and 7-48.

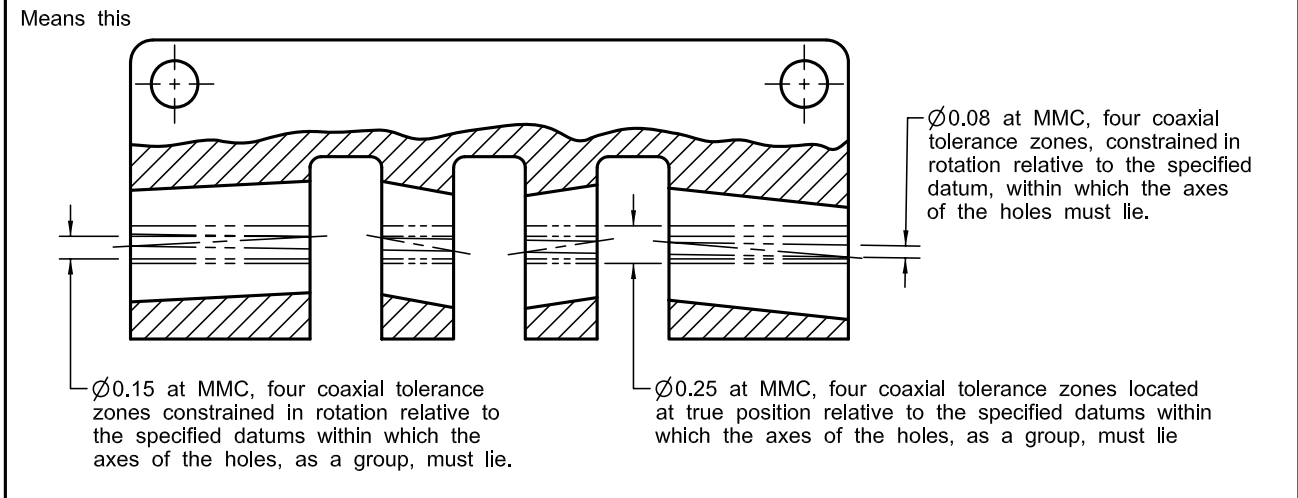
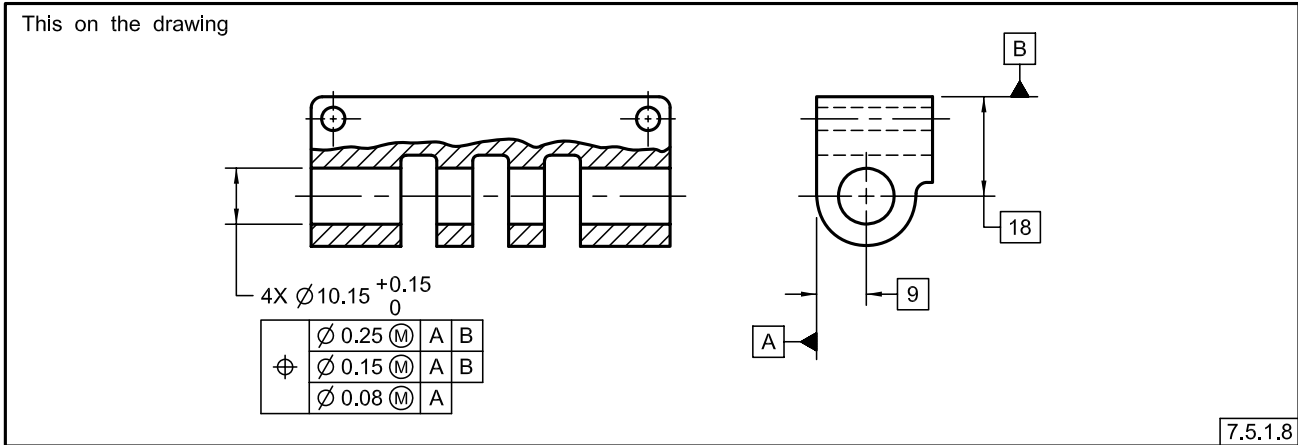
**7.5.2.1 Multiple Single-Segment Feature Control Frames.**

Where it is desired to invoke basic dimensions along with the datum references, single-segment feature control frames are used. Figure 7-46 shows two single-segment feature control frames. The lower feature control frame repeats datums A and B. Figure 7-46, illustration (a) shows that the tolerance cylinders of the tolerance zone framework for Segment 2 (as a group) are free to be translated (displaced) to the left or right as governed by the basically located tolerance cylinders of the tolerance zone framework for Segment 1, while remaining perpendicular to datum plane A and basically located to datum plane B. Figure 7-46, illustration (b) shows that the actual axes of the holes in the actual feature pattern must reside within both the tolerance cylinders of the tolerance zone framework for Segment 2 and the tolerance zone framework for Segment 1. Figure 7-46, illustration (c) repeats the heretofore-described relationships for the six-hole pattern of features shown in Fig. 7-46.

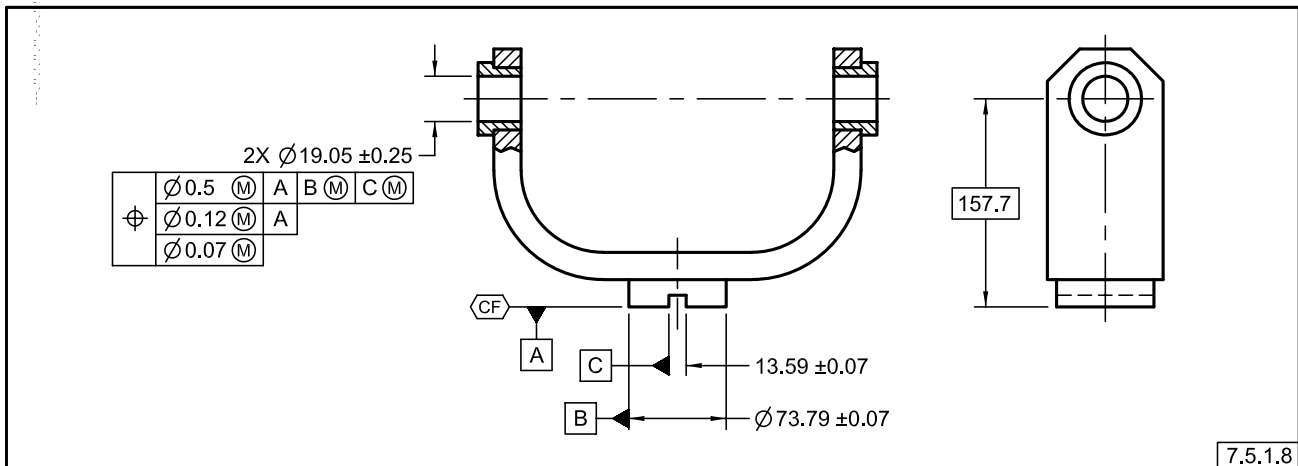
**7.5.2.2 Multiple Single Segments Applied to Patterns of Features of Size Relative to Datum Features.**

Multiple single-segment positional tolerancing may be applied to patterns of features of size on circular parts. Figure 7-47 shows two single-segment feature control frames. These are used where it is desired to establish a coaxiality relationship between the tolerance zone framework for Segment 2 and the Segment 1. Figure 7-47, illustration (a) shows that the tolerance zone framework for Segment 2 may rotate relative to the tolerance

**Fig. 7-44 Positional Tolerancing for Coaxial Holes of Same Size, Partial (Parallelism) Refinement of Feature-Relating Axis Relative to Datums A and B With Further Refinement of Parallelism to Datum A**

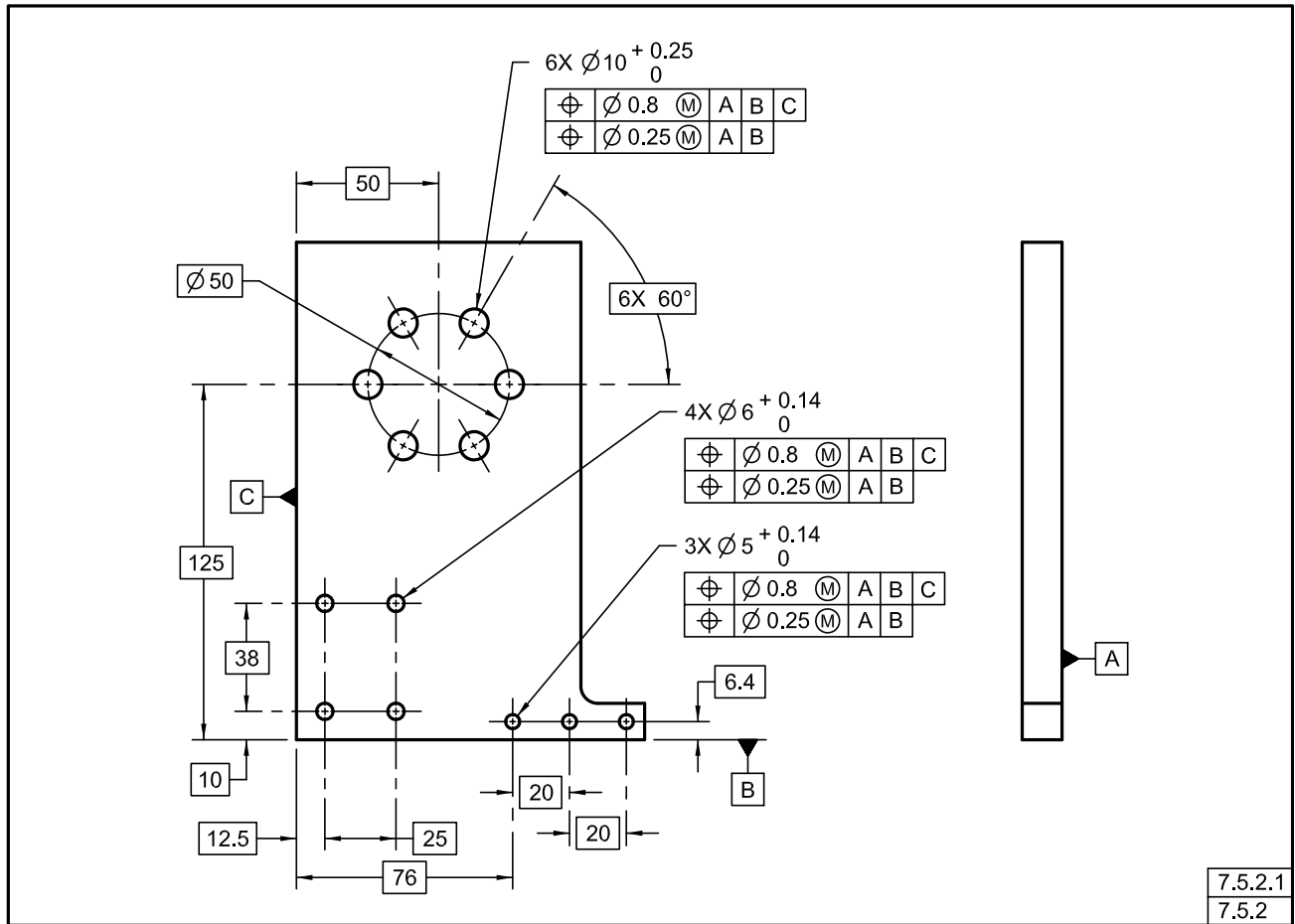


**Fig. 7-45 Three Segment Composite Tolerance**

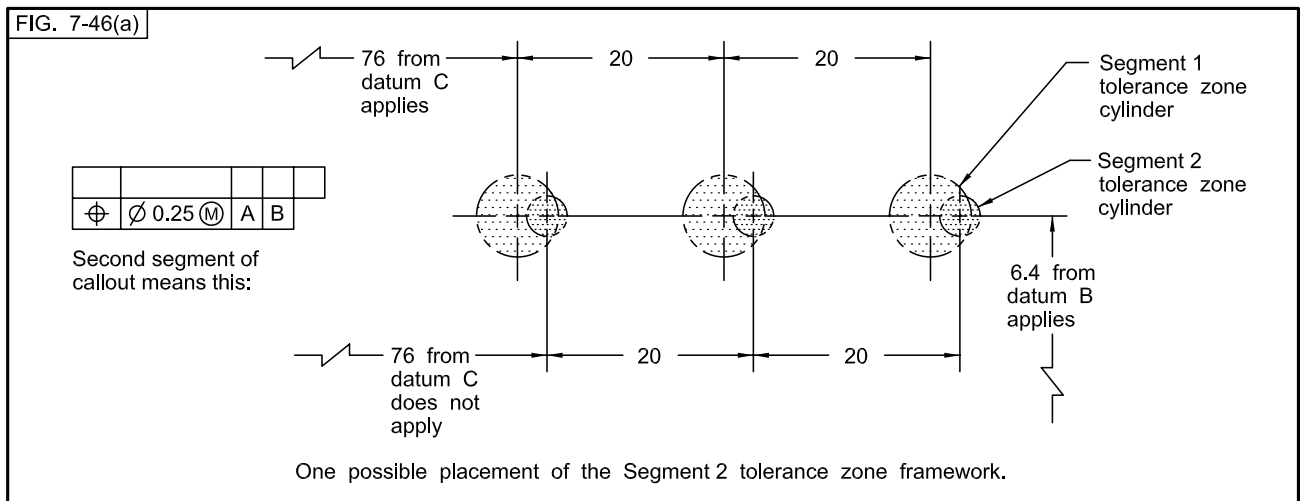




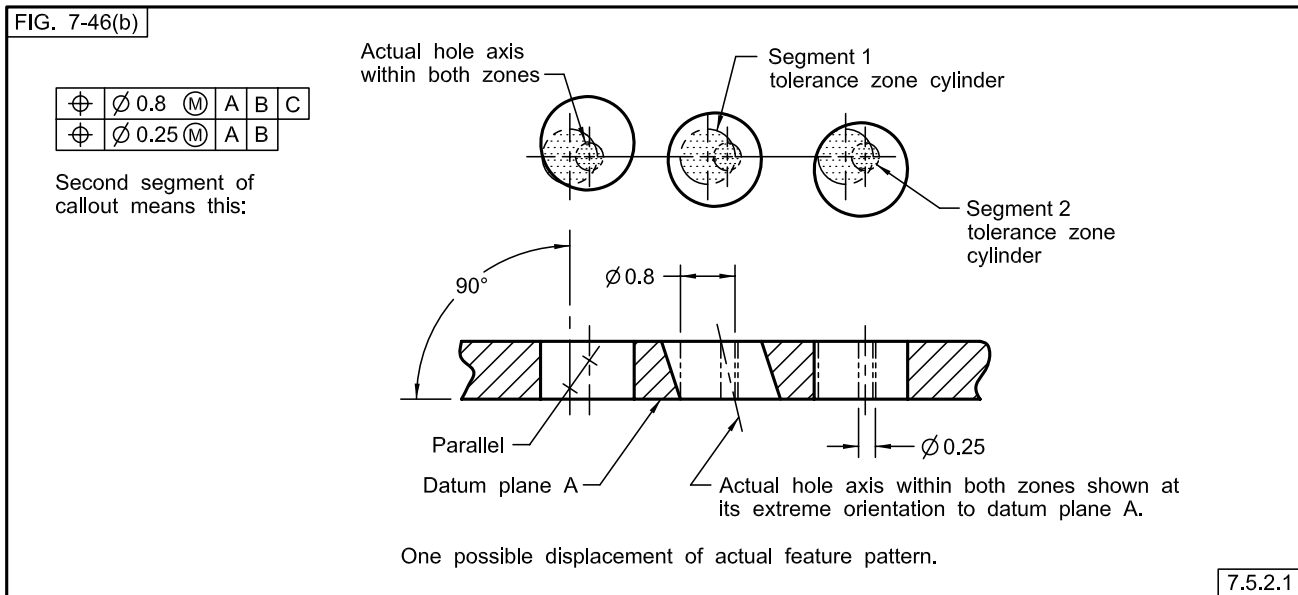
**Fig. 7-46 Hole Patterns of Fig. 7-38. Multiple Single-Segment Feature Control Frames With Secondary Datum in Lower Feature Control Frame**



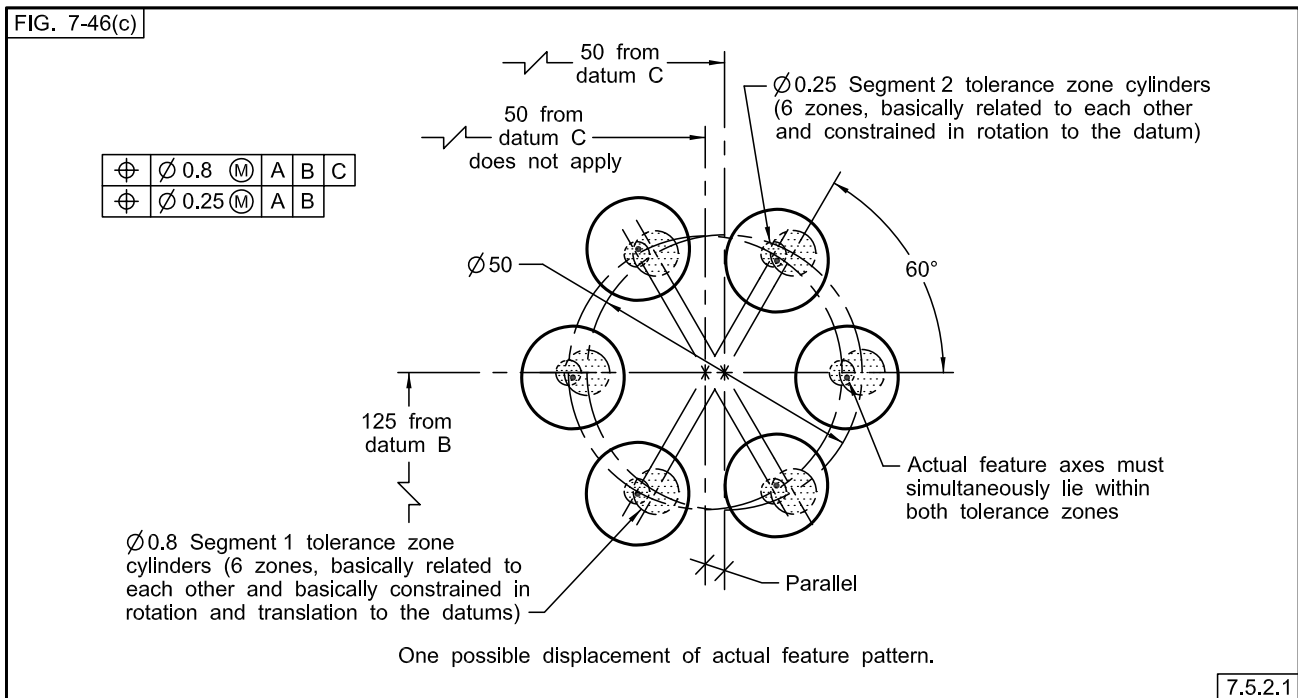
**Fig. 7-46 Hole Patterns of Fig. 7-46. Multiple Single-Segment Feature Control Frames With Secondary Datum in Lower Feature Control Frame (Cont'd) (Tolerance Zones for Three-Hole Pattern)**



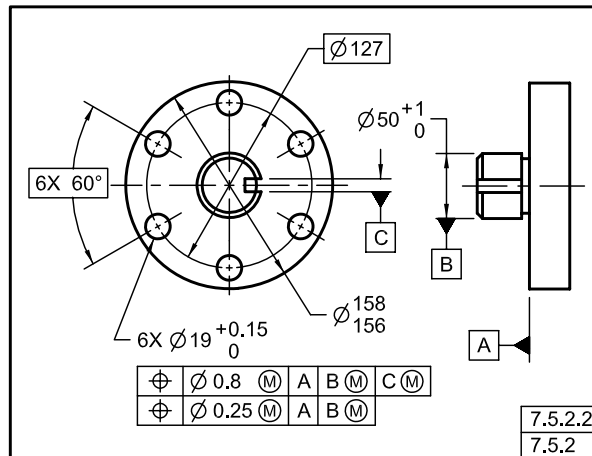
**Fig. 7-46 Hole Patterns for Fig. 7-46. Multiple Single-Segment Feature Control Frames With Secondary Datum in Lower Feature Control Frame (Cont'd) (Acceptance Boundaries for Holes in Pattern)**



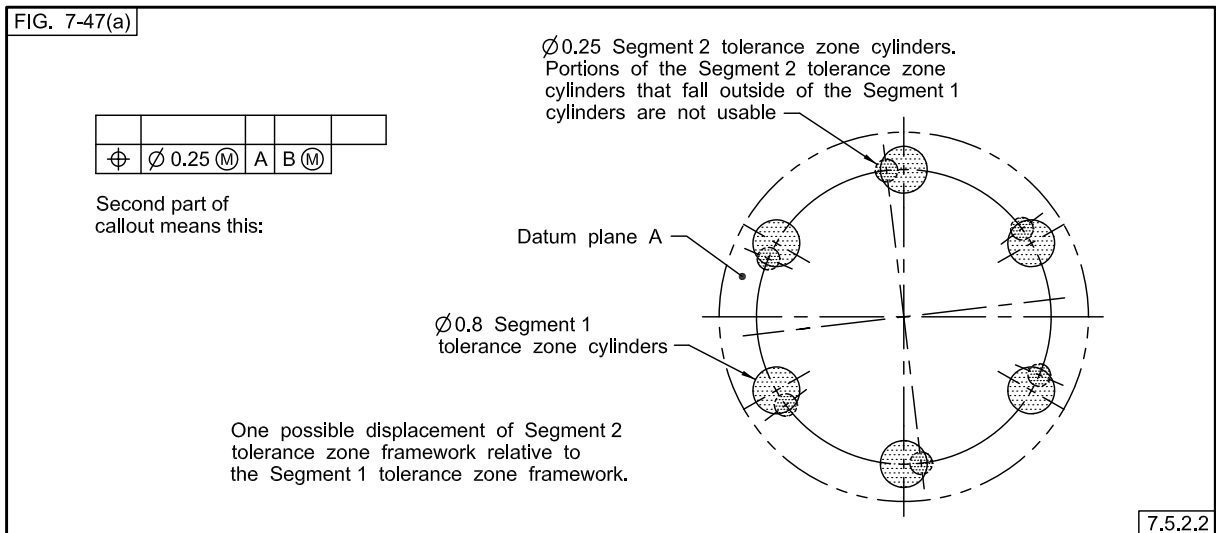
**Fig. 7-46 Hole Patterns for Fig. 7-46. Multiple Single-Segment Feature Control Frames With Secondary Datum in Lower Feature Control Frame (Cont'd) (Tolerance Zones for Six-Hole Pattern)**



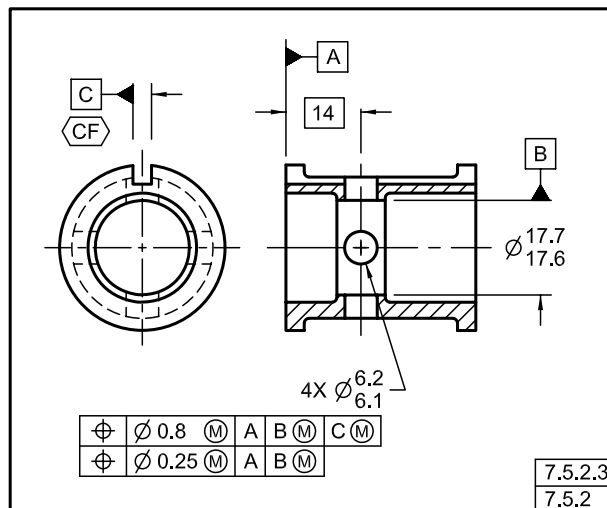
**Fig. 7-47 Positional Tolerancing With Multiple Single-Segment Feature Control Frames**



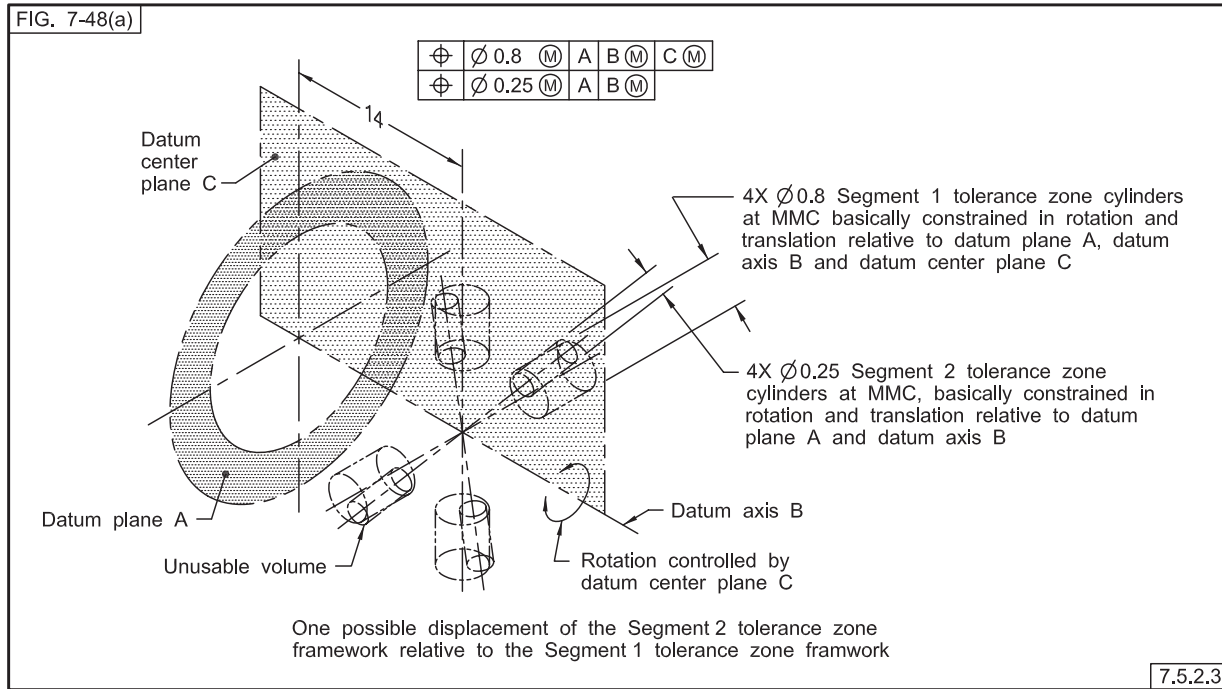
**Fig. 7-47 Multiple Single-Segment Tolerancing of a Circular Pattern of Features (Cont'd)**



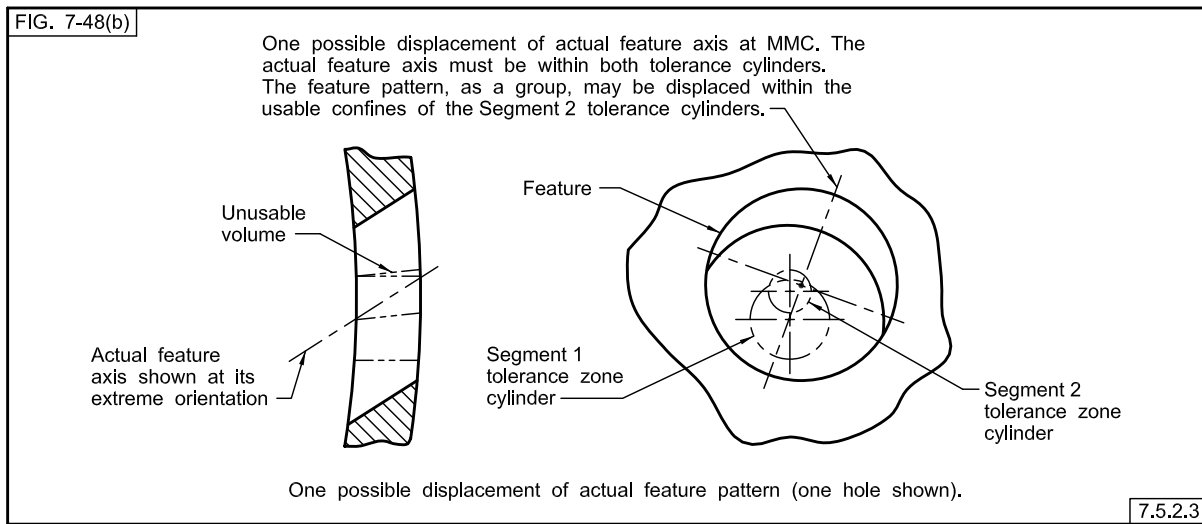
**Fig. 7-48 Radial Hole Pattern Located by Multiple Single-Segment Feature Control Frames**



**Fig. 7-48 Radial Hole Pattern Located by Multiple Single-Segment Feature Control Frames (Cont'd)  
(Tolerance Zones for Radial Hole Pattern)**



**Fig. 7-48 Radial Hole Pattern Located by Multiple Single-Segment Feature Control Frames (Cont'd)  
(Tolerance Zones for Radial Hole Pattern)**

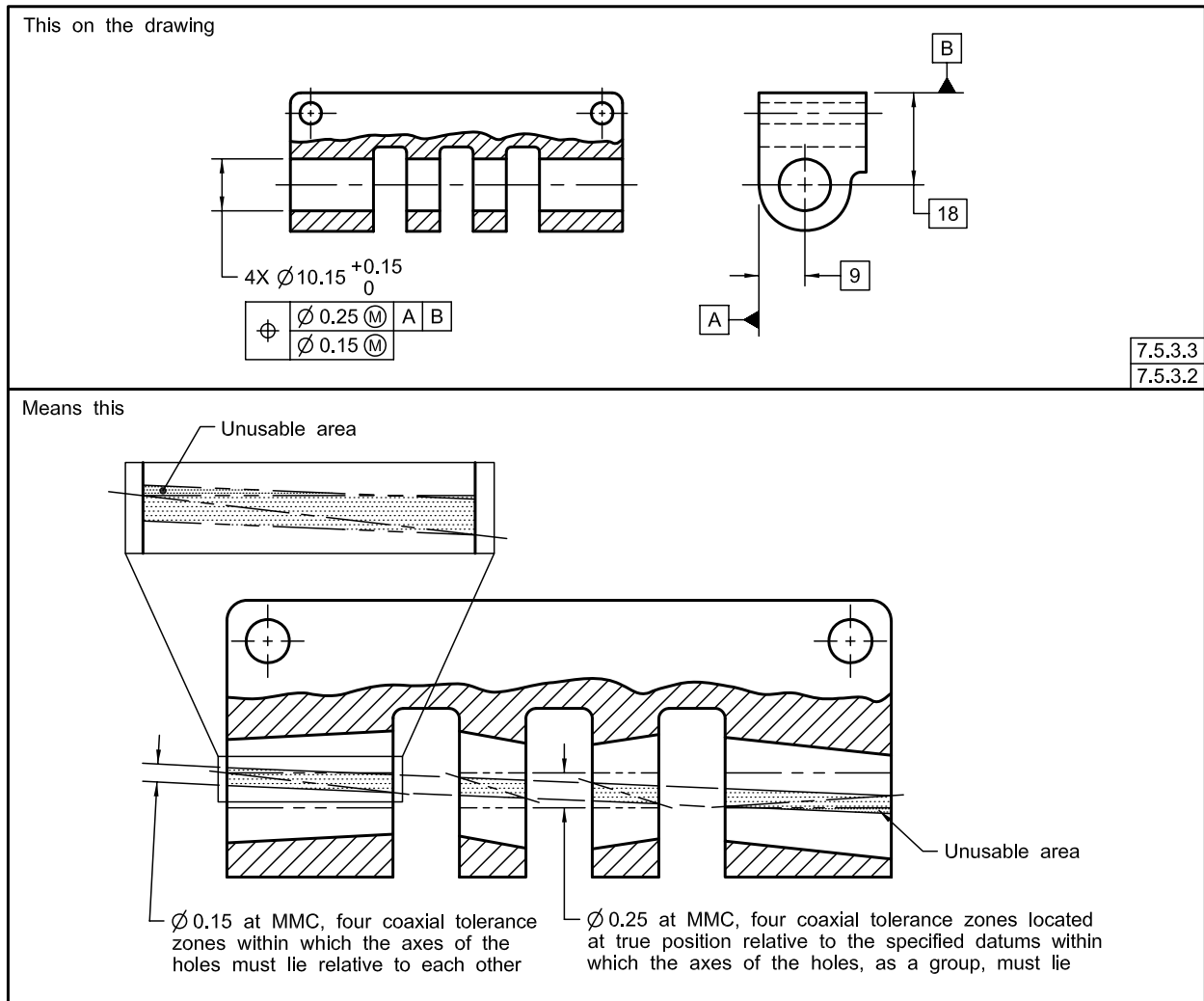


zone framework for Segment 1. The actual hole axes of the actual feature of size pattern must reside within both the tolerance cylinders of the tolerance zone framework for Segment 2 and the tolerance zone framework for Segment 1.

**7.5.2.3 Multiple Single Segments Applied to a Radial Hole Pattern.** Figure 7-48 shows two single-segment feature control frames. These are used where it is desired

to specify a need for a coaxiality relationship between the tolerance zone framework for Segment 2 and the tolerance zone framework for Segment 1. A secondary datum reference is shown in the lower feature control frame. Figure 7-48, illustration (a) shows that the tolerance zones of the tolerance zone framework for Segment 2 are parallel to datum plane A and coaxial about datum axis B. While remaining parallel and coaxial, the tolerance zone framework for Segment 2 may be displaced rotationally, as

**Fig. 7-49 Positional Tolerancing for Coaxial Holes of Same Size**



governed by the tolerance cylinders of the tolerance zone framework for Segment 1. The axes of the features in the actual feature pattern may be displaced, individually or as a pattern, within the boundaries of the smaller tolerance cylinders. Portions of the smaller tolerance zones located outside the larger tolerance zones are not usable, since the actual feature axes must reside within the boundaries of both zones. See Fig. 7-48, illustration (b).

### 7.5.3 Coaxial Positional Tolerances

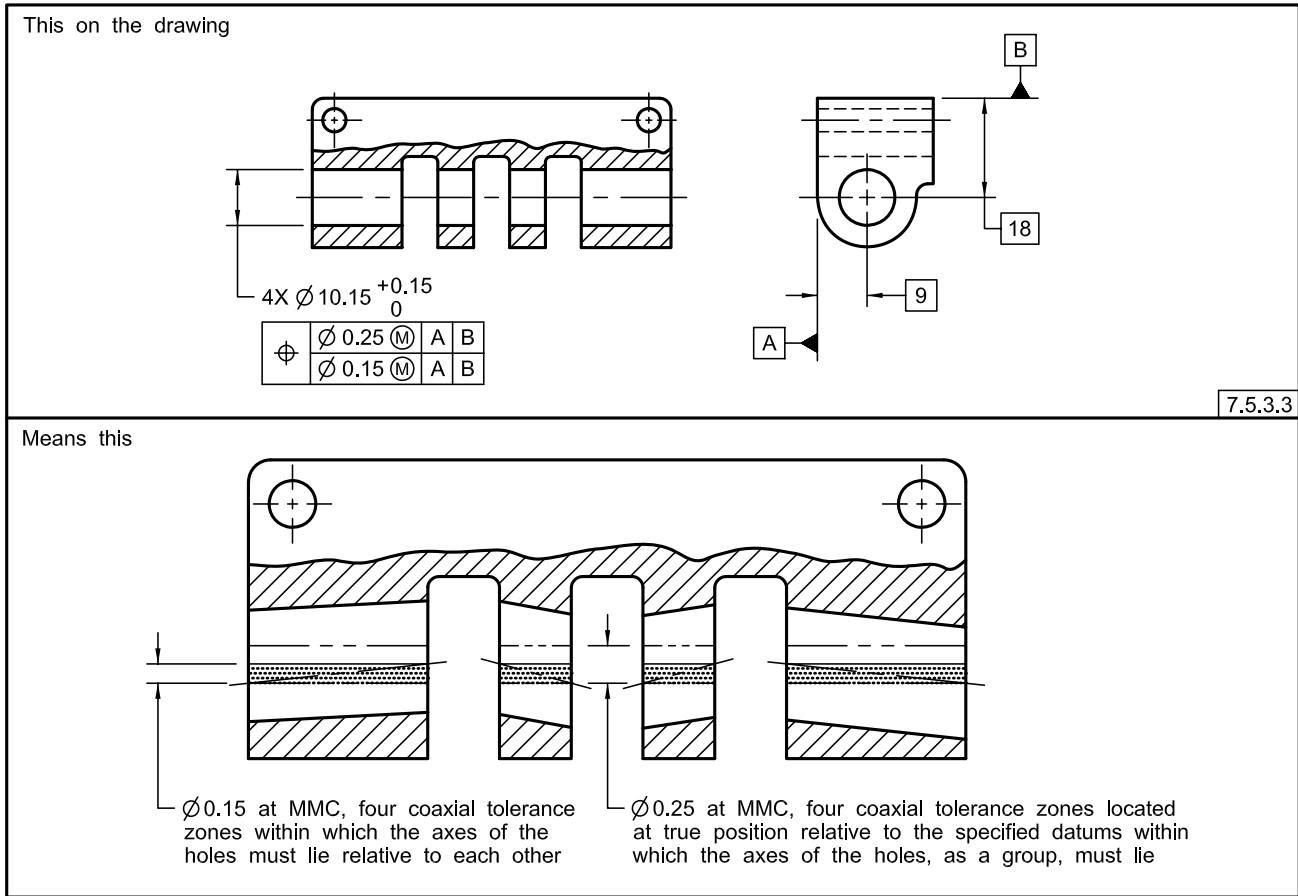
The following is an explanation of positional tolerancing as applied to coaxial patterns of features of size.

**7.5.3.1 Coaxial Pattern of Features of Size.** A composite positional tolerance may be used to control the alignment of two or more coaxial features of size. This method allows specific control of feature of size-to-feature of size coaxiality without excessively restricting the pattern-locating tolerance.

**7.5.3.2 Two or More Features of Size in Pattern-Locating Tolerance.** Controls, such as those shown in Fig. 7-49, may be specified where it is desired to produce two or more coaxial features of size within a relatively larger pattern-locating tolerance zone. The central axis of the PLTZF cylinders is parallel to datums A and B. Since the lower (feature-relating) segment of the feature control frame does not invoke orientation datums, the central axis of the FRTZF cylinders may be skewed relative to the central axis of the PLTZF cylinders. Depending upon the actually produced size of each coaxial feature of size, each individual feature of size axis may be inclined within its respective tolerance zone cylinder.

**7.5.3.3 Rotational Constraint of Feature-Relating Tolerances.** Where it is desired to refine the rotational constraint of the FRTZF cylinders as governed by the boundary established by the PLTZF cylinders, datum

**Fig. 7-50 Positional Tolerancing for Coaxial Holes of Same Size, Partial (Parallelism) Refinement of Feature-Relating Axis**



references specified in the upper segment of the frame are repeated, as applicable, and in the same order of precedence, in the lower segment of the feature control frame. See Fig. 7-50. Since the lower (feature-relating) segment of the feature control frame invokes datums A and B, the common axis of the FRTZF cylinders must be parallel to the common axis of the PLTZF cylinders. Where holes are of different specified sizes and the same requirements apply to all holes, a single feature control symbol, supplemented by a notation such as **TWO COAXIAL HOLES** is used. See Fig. 7-51. The same tolerance zone relationships apply as for Fig. 7-49.

### 7.5.4 Simultaneous Requirements

Simultaneous requirements are applicable to positional tolerances

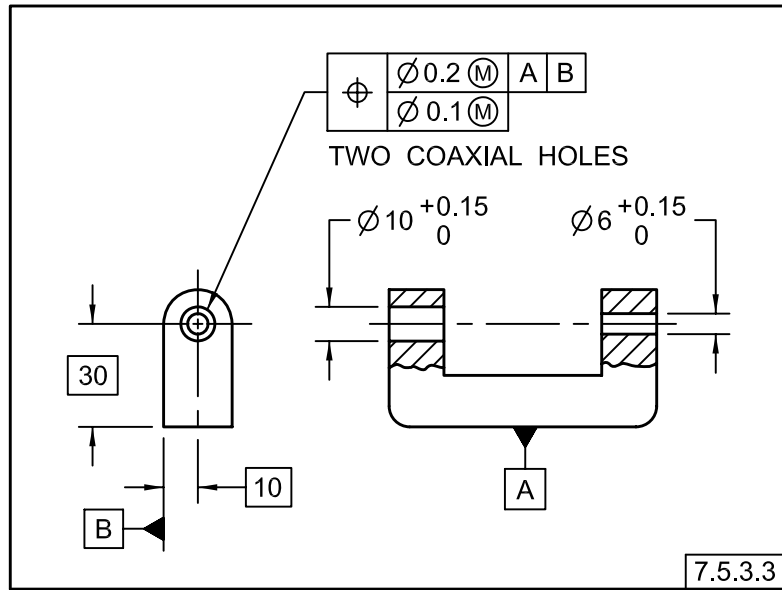
**7.5.4.1 Simultaneous Requirement: RMB.** Where multiple patterns of features of size are located relative to common datum features not subject to size tolerances, or to common datum features of size specified on an RMB basis, they are considered to be a single pattern. For example, in Fig. 7-52 each pattern of features of size

is located relative to common datum features not subject to size tolerances. Since all locating dimensions are basic and all measurements are from a common datum reference frame, positional tolerance requirements for the part are considered a single requirement as illustrated by Fig. 7-53. The actual centers of all holes must lie on or within their respective tolerance zones when measured from datums A, B, and C.

NOTE: The explanation given in Fig. 7-53 still applies where independent verification of pattern locations becomes necessary due to size or complexity of the part.

**7.5.4.2 Simultaneous Requirement: MMB.** Where any of the common datums in multiple patterns of features of size is specified on an MMB basis, there is an option whether the patterns are to be considered as a single pattern or as having separate requirements. If no note is added adjacent to the feature control frames, the patterns are to be treated as a single pattern. Where it is desired to permit the patterns to be treated as separate patterns, a notation such as **SEP REQ** is placed adjacent to each feature control frame. See Fig. 7-54. This allows

**Fig. 7-51 Positional Tolerancing for Coaxial Holes of Different Sizes**



**Fig. 7-52 Multiple Patterns of Features**

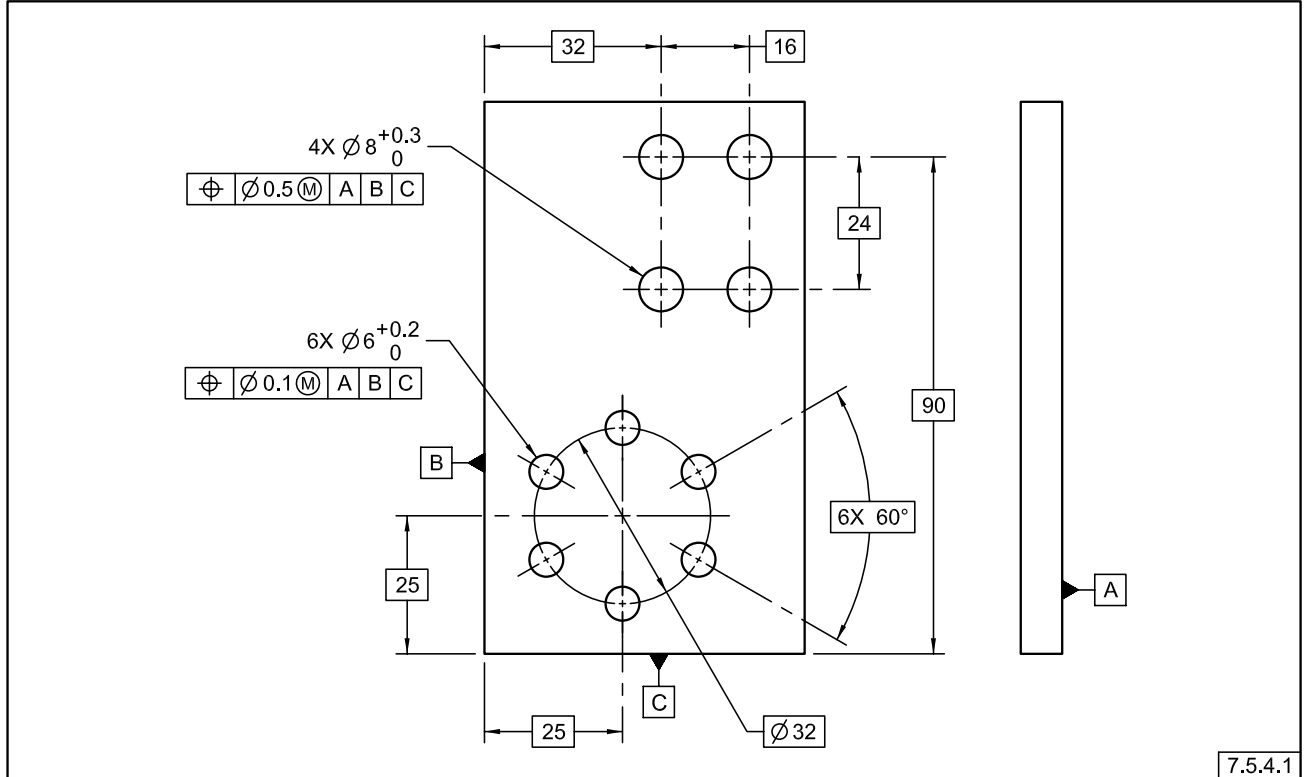
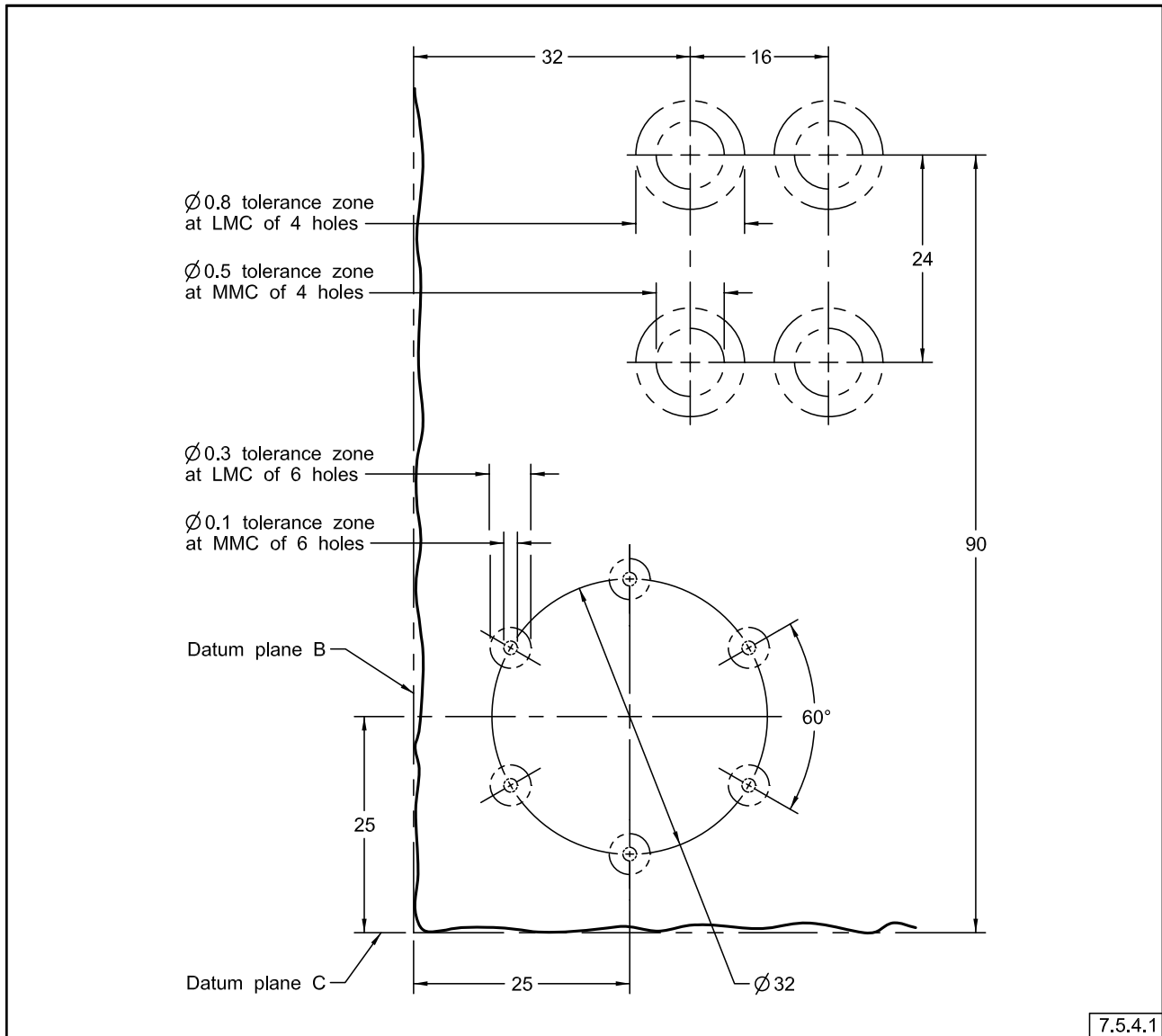


Fig. 7-53 Tolerance Zones for Patterns Shown in Fig. 7-52



7.5.4.1

the datum features of size to establish a separate datum reference frame for each pattern of features of size, as a group. These datum reference frames may translate and rotate independently of each other, resulting in an independent relationship between the patterns. This principle does not apply to the lower segments of composite feature control frames except as noted in para. 4.19.

### 7.5.5 Multiple Positional Tolerances for a Pattern of Features of Size

If different datums, different datum modifiers, or the same datums in a different order of precedence are

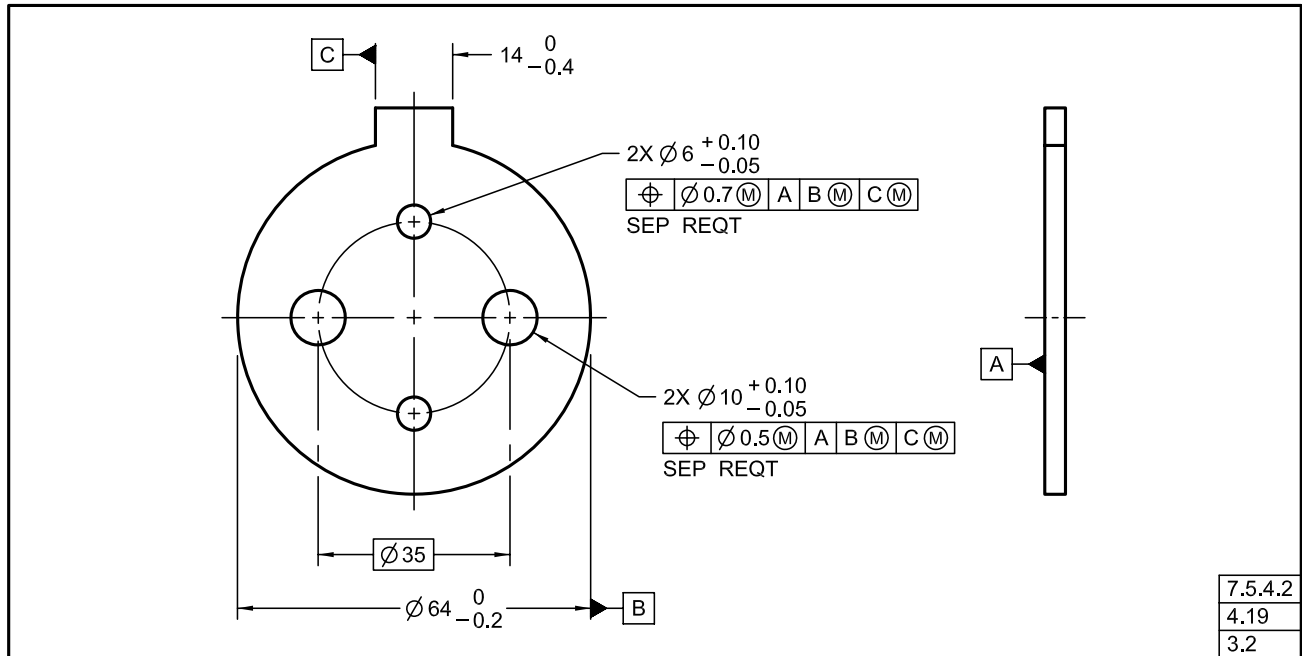
specified, this constitutes a different datum reference frame and design requirements. This is not to be specified using the composite positional tolerancing method. A separately specified tolerance, using a second single-segment feature control frame is used, including applicable datums, as an independent requirement. See Fig. 7-55.

### 7.6 COAXIAL FEATURE CONTROLS

Coaxiality is that condition where the axes of the unrelated actual mating envelope, axis of the unrelated minimum material envelope, or median points, as applicable of one or more surfaces of revolution, are coincident



Fig. 7-54 Multiple Patterns of Features, Separate Requirements



with a datum axis or another feature axis. The amount of permissible variation from coaxiality may be expressed by a variety of means, including a positional tolerance, a runout tolerance, a concentricity tolerance, or a profile of a surface tolerance.

### 7.6.1 Selection of Coaxial Feature Controls

Selection of the proper control depends on the functional requirements of the design.

(a) Where the axis or surface of features must be controlled, and the use of RFS, MMC, or LMC material condition is applicable, positional tolerancing is recommended. See para. 7.6.2.

(b) Where the surface of a feature must be controlled relative to the datum axis, runout tolerancing is recommended. See para. 9.2.

(c) Where the relationship between the derived median points of the controlled feature and the datum axis is a primary design concern, or where the coaxial control of noncircular features is a design requirement, concentricity tolerancing is recommended. See para. 7.6.4 and the note in para. 7.6.4.1.

(d) Where it is desired to achieve a combined control of size, form, orientation, and location of a feature within the stated tolerance, profile tolerancing is recommended. See para. 7.6.5.

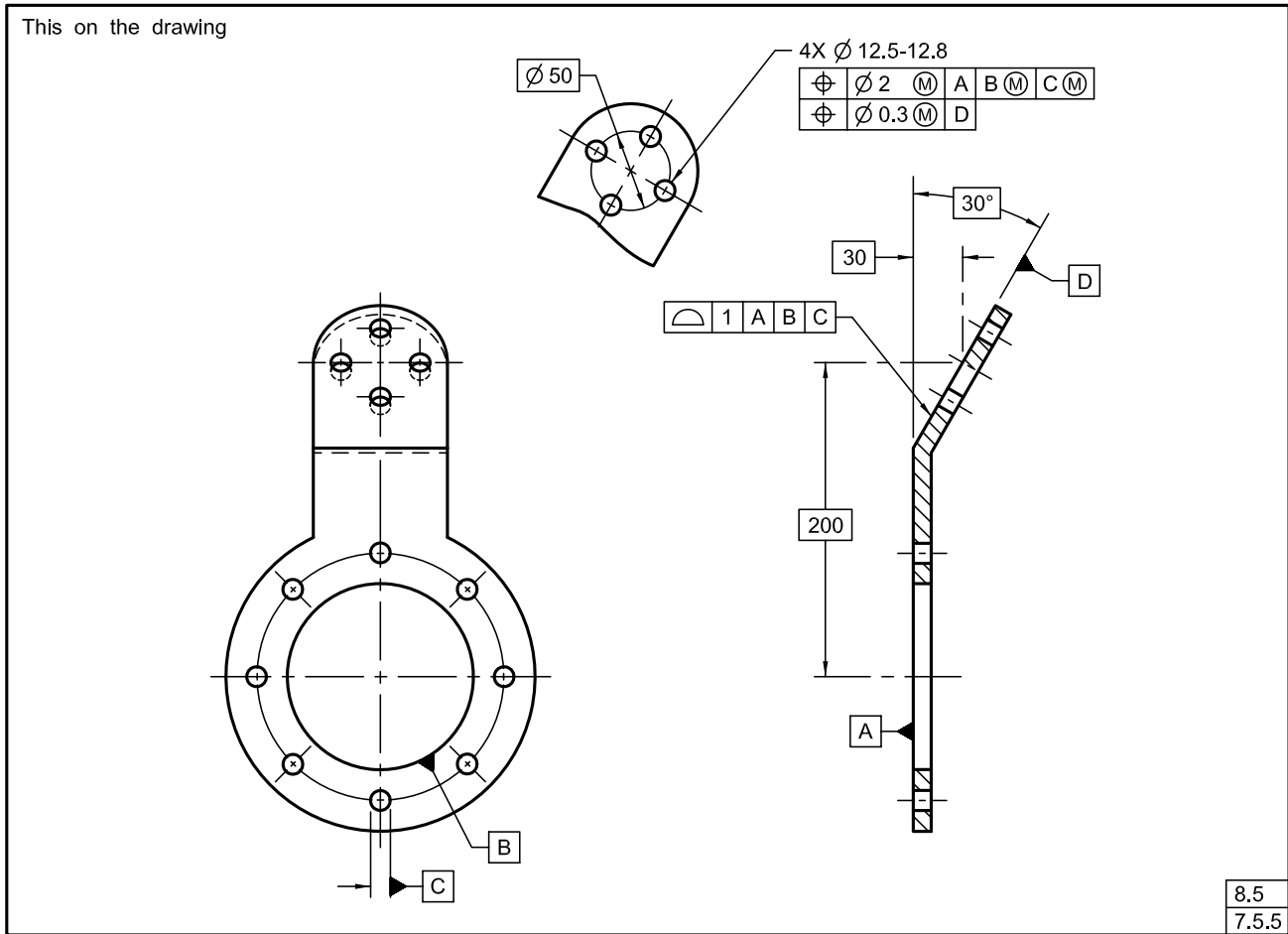
### 7.6.2 Positional Tolerance Control

Where the surfaces of revolution are cylindrical and the control of the axes can be applied on a material condition basis, positional tolerancing is recommended.

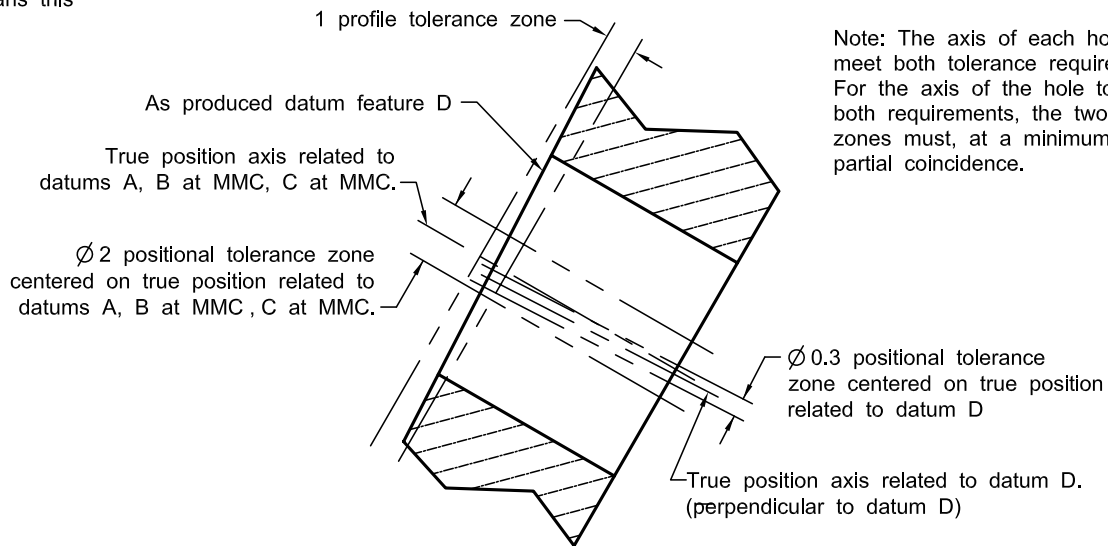
**7.6.2.1 Coaxial Relationships.** A coaxial relationship may be controlled by specifying a positional tolerance at MMC. See Fig. 7-56. A coaxial relationship may also be controlled by specifying a positional tolerance at RFS (as in Fig. 7-57) or LMC (as in Fig. 7-17). The datum feature may be specified on an MMB, LMB, or an RMB basis, depending upon the design requirements. In Fig. 7-56, the datum feature is specified on an MMB basis. In such cases, any departure of the datum feature from MMB may result in an additional displacement between its axis and the axis of the considered feature. See the conditions shown in Fig. 7-58. Where two or more features are coaxially related to such a datum (e.g., a shaft having several diameters) the considered features are displaced as a group relative to the datum feature, as explained in para. 7.5.3.2 for a pattern of features.

**7.6.2.2 Coaxial Features Controlled Within Limits of Size.** Where it is necessary to control coaxiality of related features within their limits of size, a zero positional tolerance at MMC is specified. The datum feature

Fig. 7-55 Multiple Positional Tolerancing for a Pattern of Features

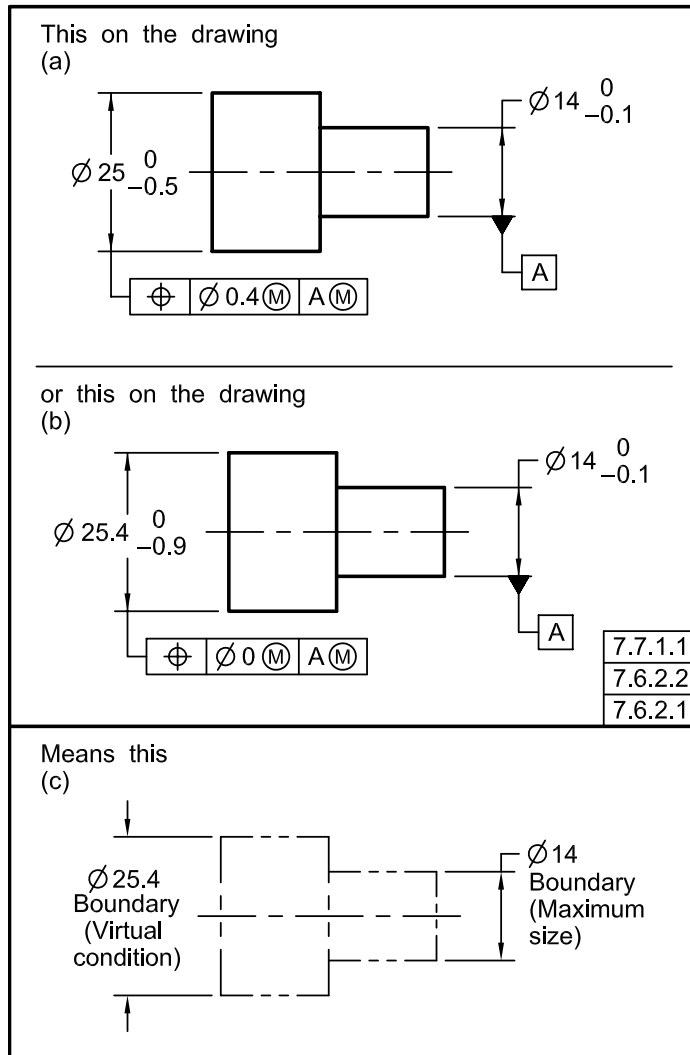


Means this



Note: The axis of each hole must meet both tolerance requirements. For the axis of the hole to meet both requirements, the two tolerance zones must, at a minimum, have partial coincidence.

**Fig. 7-56 Positional Tolerancing for Coaxiality**



**Fig. 7-57 Feature Controlled With Positional Tolerance at RFS and Datum Referenced at RMB for Coaxiality**

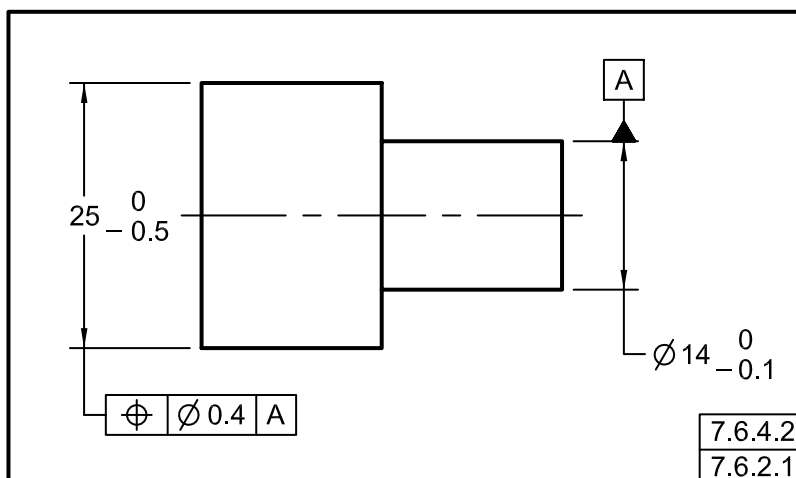
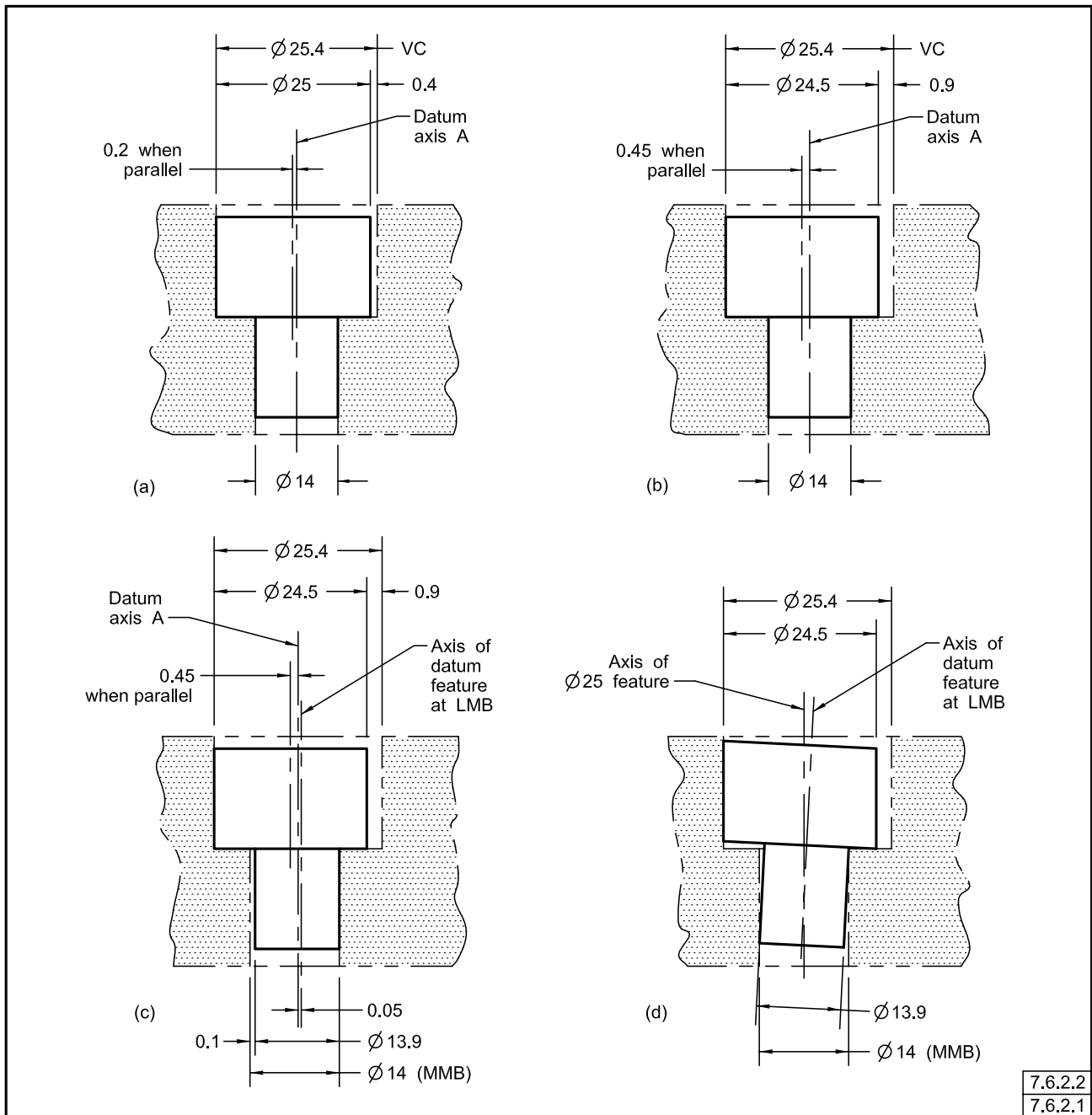


Fig. 7-58 Some of the Allowable Conditions of Part Shown in Fig. 7-56

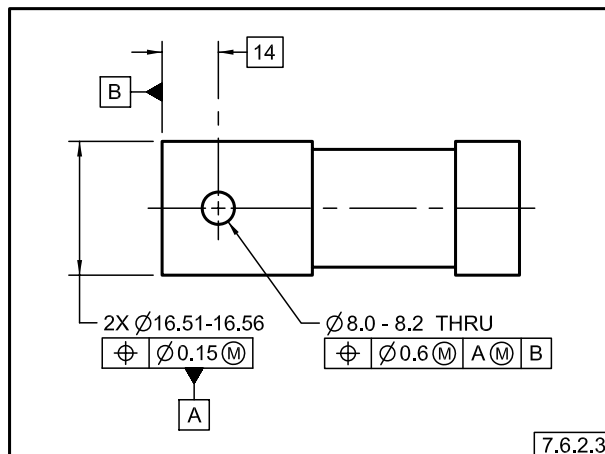


is normally specified on an MMB basis. See Fig. 7-56, illustration (b). The tolerance establishes coaxial boundaries of perfect form. Variations in coaxiality between the features are permitted only where the features depart from their MMC sizes toward LMC. The allowable positional variation is within the “means this” portion of Fig. 7-56. See Fig. 7-58 for possible displacements.

**7.6.2.3 Coaxial Features Without Datum References.** A coaxial relationship may be controlled by

specifying a positional tolerance without datum references, as shown in Fig. 7-59. This method allows specific control of feature-to-feature coaxiality. Where features are specified with different sizes, a single feature control frame, supplemented by a notation, such as **TWO COAXIAL FEATURES**, is used. A positional tolerance specification with no datum reference creates a relationship between the toleranced features, but implies no relationship to any other features. The toleranced features may be identified as a single datum feature that may then

Fig. 7-59 Two Datum Features, Single Datum Axis



be referenced in the feature control frames of other features, as needed.

### 7.6.3 Runout Tolerance Control

For information on controlling surfaces of revolution, such as cylinders and cones, relative to a datum axis, with a runout tolerance, see para. 9.2.

### 7.6.4 Concentricity

Concentricity is that condition where the median points of all diametrically opposed elements of a surface of revolution (or the median points of correspondingly located elements of two or more radially disposed features) are congruent with a datum axis (or center point).

**7.6.4.1 Concentricity Tolerancing.** A concentricity tolerance is a cylindrical (or spherical) tolerance zone whose axis (or center point) coincides with the axis (or center point) of the datum feature(s). The median points of all correspondingly located elements of the feature(s) being controlled, regardless of feature size, must lie within the cylindrical (or spherical) tolerance zone. The specified tolerance can only apply on an RFS basis, and the datum reference can only apply on an RMB basis. See Fig. 7-60. Unlike the positional control defined in para. 7.6.2, where measurements taken along a surface of revolution are made to determine the location (eccentricity) of the axis or center point, a concentricity tolerance requires the establishment and verification of the feature's median points.

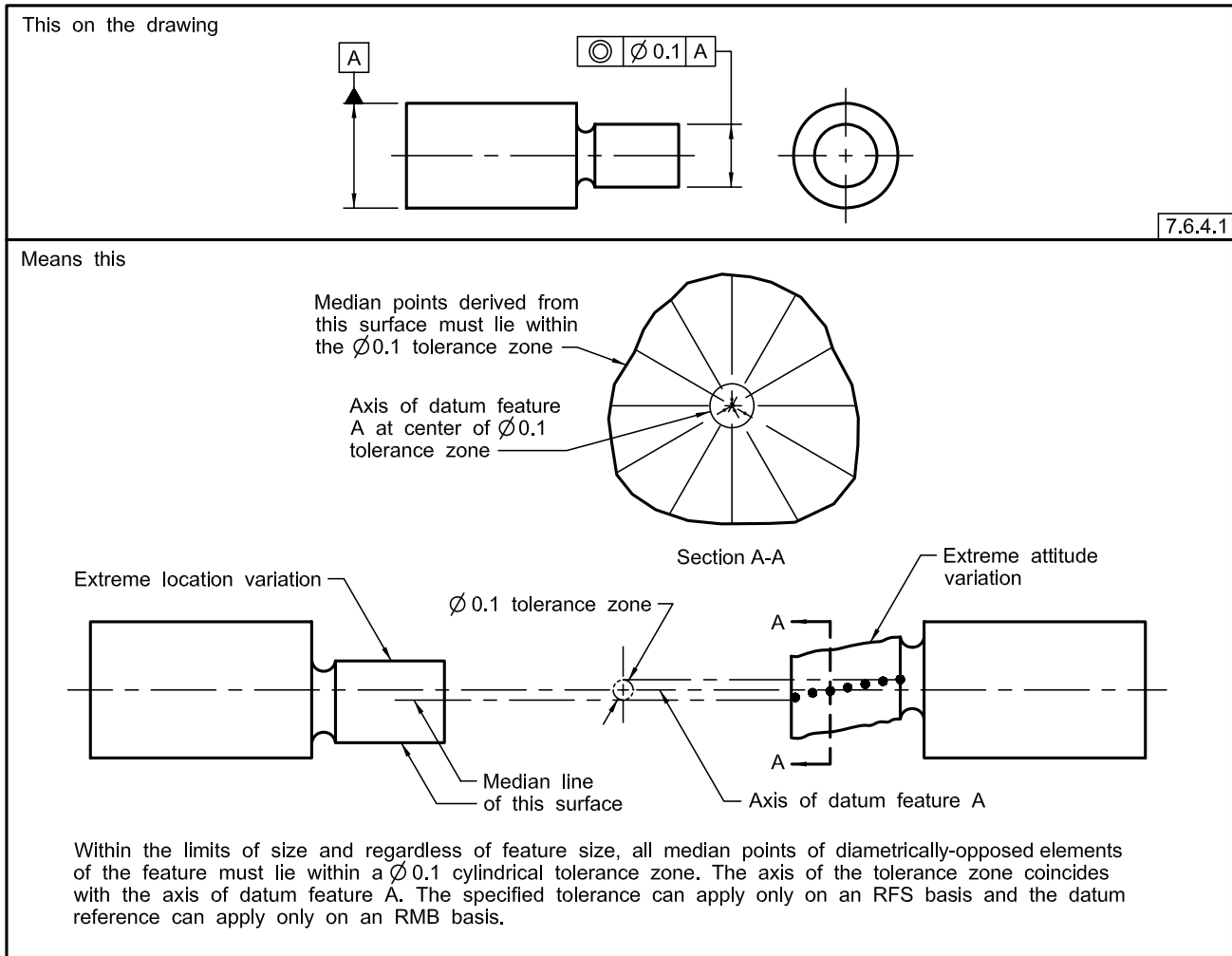
NOTE: Concentricity requirement as described above is substantially different than position, profile, or runout tolerances.

**7.6.4.2 Differences Between Concentricity and Other Coaxiality Controls.** The items shown in Figs. 7-61 and 7-62 are two possible acceptable configurations of the item depicted in Fig. 7-57.

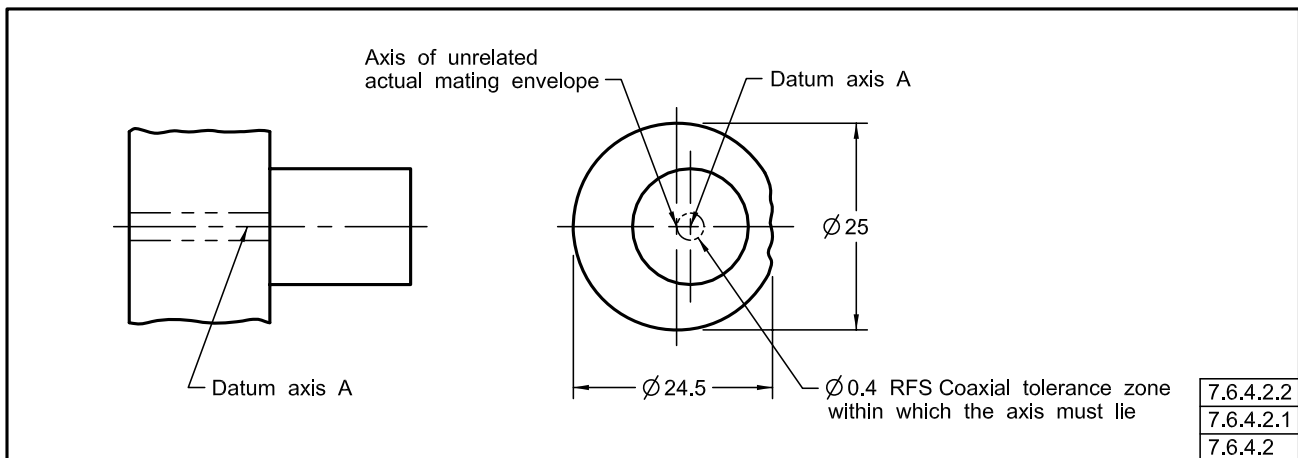
**7.6.4.2.1 Controlling Features With Positional Tolerances.** In Fig. 7-61, the axis of the controlled feature's unrelated actual mating envelope has been displaced 0.2 to the left, relative to the axis of datum feature A, and 0.5 material has been removed from the right side of the feature's surface. In Fig. 7-62, the axis of the controlled feature's unrelated actual mating envelope has also been displaced 0.2 to the left, relative to the axis of datum feature A, while 0.25 material has been removed from the upper side of the feature's surface and 0.25 material has been removed from the lower side of the feature's surface. Since the size of the unrelated actual mating envelope of the controlled features in Figs. 7-61 and 7-62 is 25 diameter, the controlled features remain within acceptable limits of size. For coaxial positional tolerance, the location of the axis of the feature's unrelated actual mating envelope is controlled relative to the axis of the datum feature. Where checked for a coaxial positional tolerance relationship, the items depicted in Figs. 7-61 and 7-62 are acceptable.

**7.6.4.2.2 Controlling Features With Concentricity.** For concentricity, the locations of the midpoints of diametrically opposed (or the median points of correspondingly located) feature elements are controlled relative to a datum axis. See Fig. 7-63. Where the items depicted in Figs. 7-61 and 7-62 are checked for a concentricity relationship, only the part depicted in Fig. 7-62 would be acceptable, since the midpoints of some of the diametrically opposed elements in Fig. 7-61 would exceed

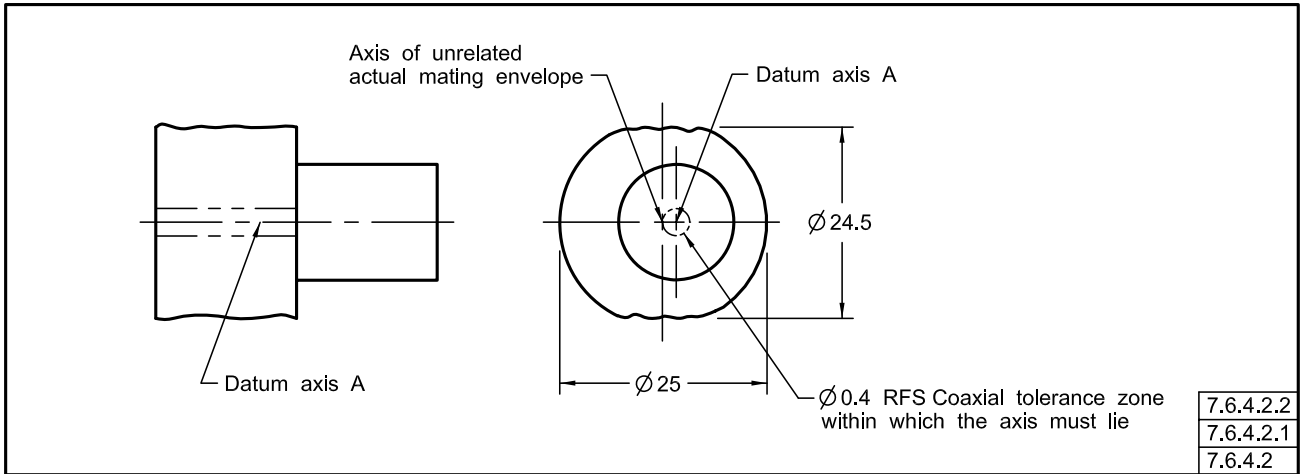
**Fig. 7-60 Concentricity Tolerancing**



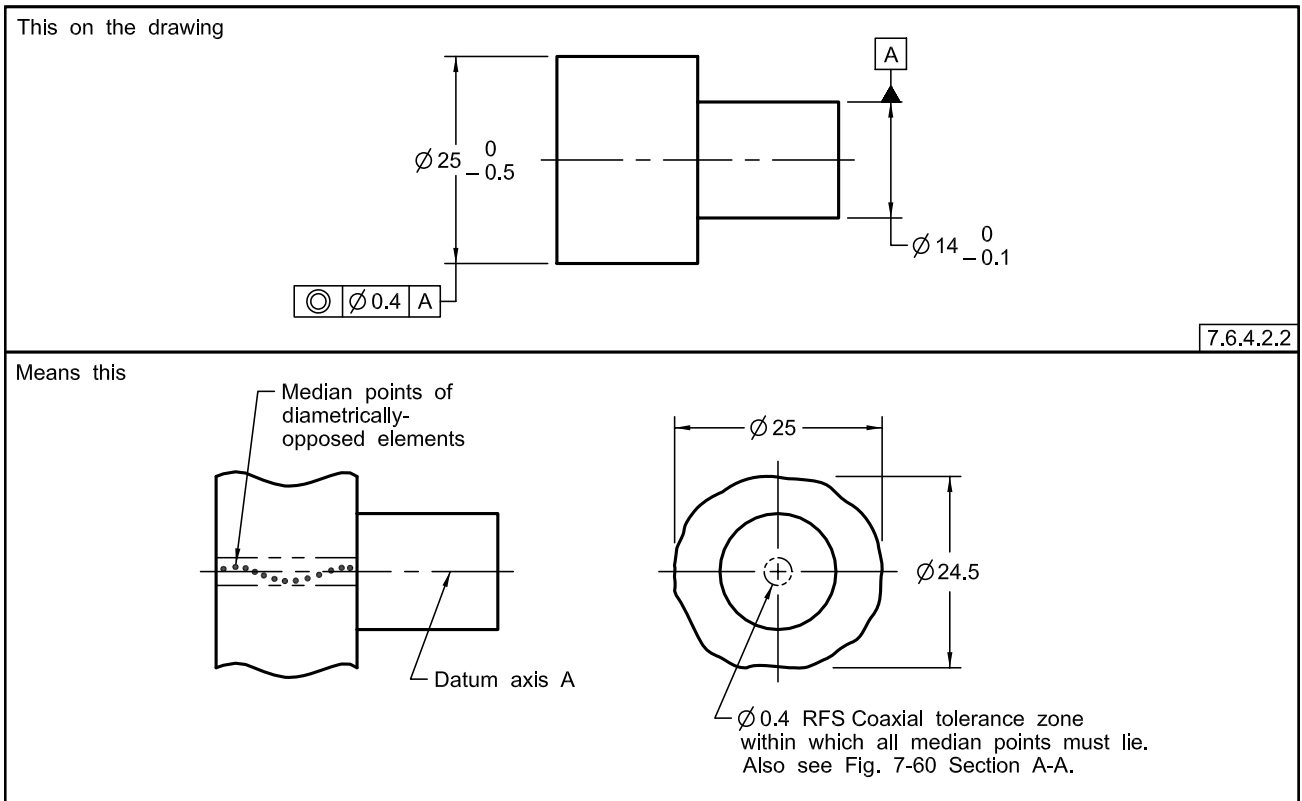
**Fig. 7-61 One Possible Acceptable Configuration of Part Depicted in Fig. 7-57**



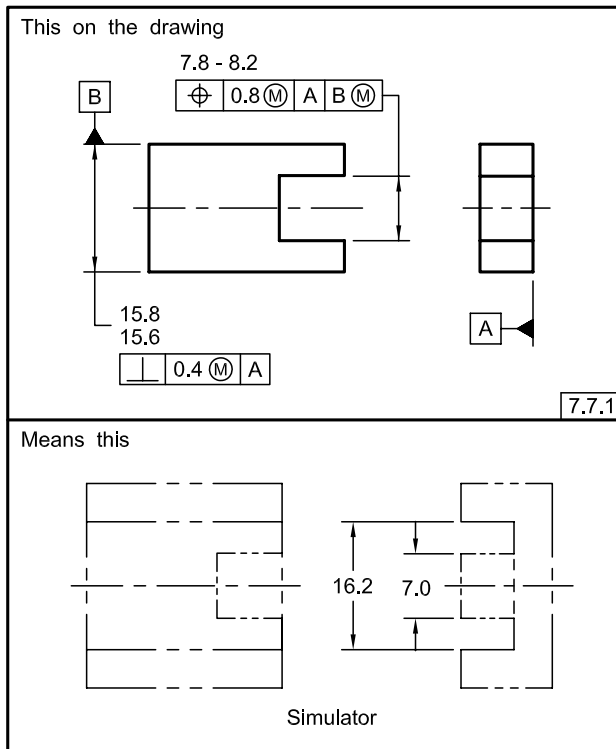
**Fig. 7-62 One Possible Acceptable Configuration of Part Depicted in Fig. 7-57**



**Fig. 7-63 Item Depicted in Fig. 7-57 Controlled for Concentricity**



**Fig. 7-64 Positional Tolerancing at MMC for Symmetrical Features**



the boundary of the 0.4-diameter concentricity tolerance cylinder.

### 7.6.5 Profile of a Surface Tolerance Control

For information on controlling the coaxiality of a surface of revolution relative to a datum axis with profile of a surface tolerance, see para. 8.4.2.

## 7.7 TOLERANCING FOR SYMMETRICAL RELATIONSHIPS

Symmetrical relationships may be controlled using either positional, profile, or symmetry tolerances. However, significant requirement differences are established by these tolerance controls. Positional tolerancing for symmetrical relationships establishes a requirement where the center plane of the unrelated actual mating envelope of one or more features is congruent with a datum axis or center plane within specified limits.

MMC, LMC, or RFS may apply to the tolerance, and MMB, LMB, or RMB may be applied to the datum feature. Symmetry tolerancing is explained in para. 7.7.2. Profile tolerancing is explained in Section 8.

### 7.7.1 Positional Tolerancing at MMC

A symmetrical relationship may be controlled by specifying a positional tolerance at MMC as in Fig. 7-64. The explanations given in subparas. 7.4.5.1(a) and (b) apply to the considered feature. The datum feature may be specified either on an MMB, LMB, or RMB basis, depending upon the design requirements.

**7.7.1.1 Zero Positional Tolerancing at MMC for Symmetrical Relationships.** Where it is necessary to control the symmetrical relationship of related features within their limits of size, a zero positional tolerance at MMC is specified. The tolerance establishes symmetrical boundaries of perfect form. Variations in position between the features are permitted only where the features depart from their MMC sizes toward LMC. This application is the same as that shown in Fig. 7-56, illustration (b) except that it applies a tolerance to a center plane location.

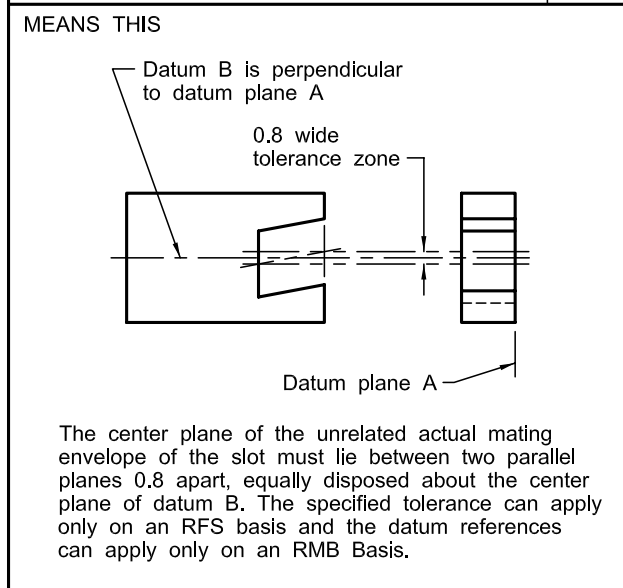
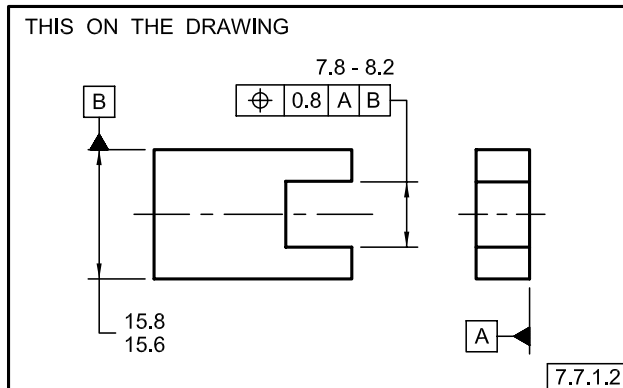
**7.7.1.2 Positional Tolerancing RFS.** Some designs may require a control of the symmetrical relationship between features to apply regardless of their actual sizes. In such cases, the specified positional tolerance is applied at RFS, and the datum reference is applied at RMB. See Fig. 7-65.

### 7.7.2 Symmetry Tolerancing to Control the Median Points of Opposed or Correspondingly Located Elements of Features

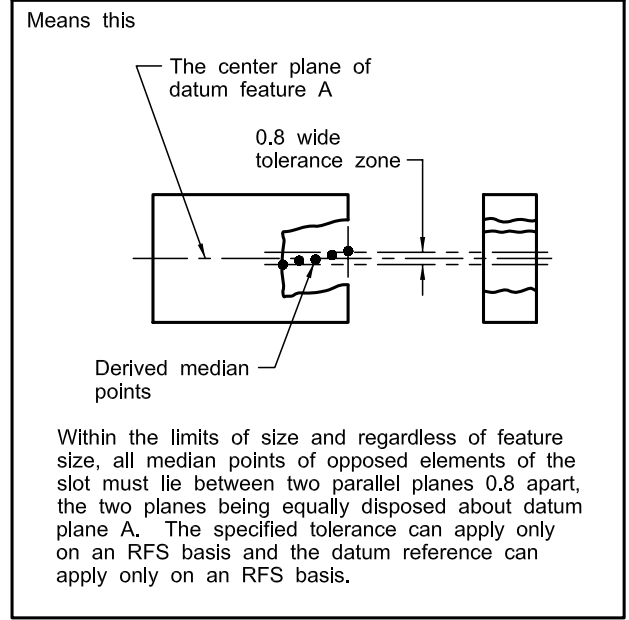
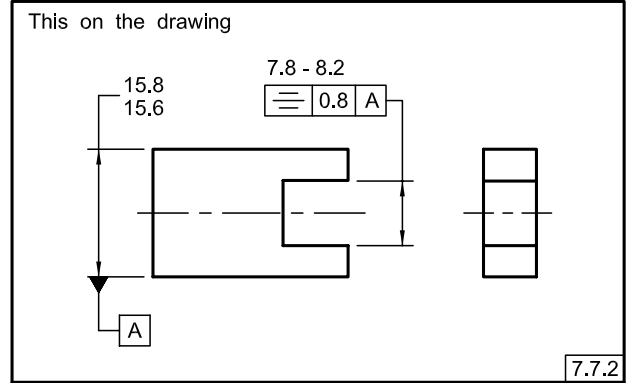
Symmetry is that condition where the median points of all opposed or correspondingly located elements of two or more feature surfaces are congruent with a datum axis or center plane. Where design requirements dictate a need for the use of a symmetry tolerance and symbol, the method shown in Fig. 7-66 may be followed. The explanation given in para. 7.6.4 applies to the considered feature(s), since symmetry and concentricity controls are the same concept, except as applied to different part configurations. Symmetry tolerance can only be applied RFS and the datum reference can only be applied RMB.



**Fig. 7-65 Positional Tolerancing RFS for Symmetrical Features**



**Fig. 7-66 Symmetry Tolerancing**



## Section 8

# Tolerances of Profile

### 8.1 GENERAL

This Section establishes the principles and methods of dimensioning and tolerancing to control the profile of various features.

### 8.2 PROFILE

A profile is an outline of a surface, a shape made up of one or more features, or a two-dimensional element of one or more features. Profile tolerances are used to define a tolerance zone to control form or combinations of size, form, orientation, and location of a feature(s) relative to a true profile. Depending upon the design requirements, profile tolerance zones may or may not be related to datums. A digital data file or an appropriate view on a drawing shall define the true profile. A true profile is a profile defined by basic radii, basic angular dimensions, basic coordinate dimensions, basic size dimensions, undimensioned drawings, formulas, or mathematical data, including design models. Where used as a refinement of a size tolerance created by toleranced dimensions, the profile tolerance must be contained within the size limits. For more information on design models, see ASME Y14.41.

#### 8.2.1 Types of Profile Tolerances

A profile tolerance may be applied to an entire part, multiple features, individual surfaces, or to individual profiles taken at various cross sections through a part. The two types of profile tolerances — profile of a surface and profile of a line — are explained in paras. 8.2.1.1 and 8.2.1.2:

**8.2.1.1 Profile of a Surface.** The tolerance zone established by the profile of a surface tolerance is three-dimensional (a volume), extending along the length and width (or circumference) of the considered feature or features. Profile of a surface may be applied to parts of any shape, including parts having a constant cross section as in Fig. 8-5, parts having a surface of revolution as in Fig. 8-17, or parts having a profile tolerance applied all over as in Fig. 8-8. Where the extent of the application of the profile tolerance is unclear, the between symbol should be used.

**8.2.1.2 Profile of a Line.** Each line element tolerance zone established by the profile of a line tolerance requirement is two-dimensional (an area) and the tolerance zone is normal to the true profile of the feature at each line element. A design solid model or a drawing view is created to show the true profile. Profile of a line may be applied to parts having a varying cross section, such as the tapered wing of an aircraft, or a constant cross section, such as an extrusion, where it is not desired to have a tolerance zone include the entire surface of the feature as a single entity. See Fig. 8-27.

#### 8.2.2 Profile Specification

The profile tolerance zone specifies a uniform or nonuniform tolerance boundary along the true profile within which the surface or single elements of the surface must lie.

#### 8.2.3 Profile Tolerances as General Requirements

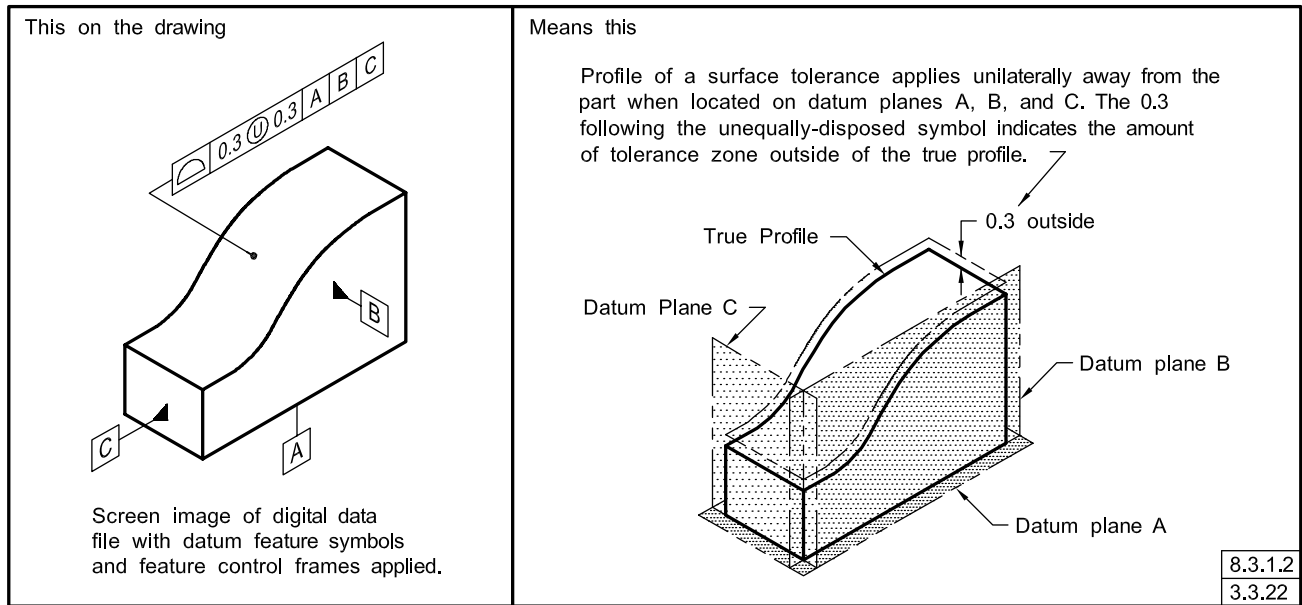
Where the profile tolerance feature control frame is placed in a general note or the general tolerance block, the tolerance applies to all features unless otherwise specified.

### 8.3 TOLERANCE ZONE BOUNDARIES

Uniform, bilateral, unequally disposed, or non-uniform tolerance zones can be applied to profile tolerances.

#### 8.3.1 Uniform Tolerance Zone

A uniform tolerance zone is the distance between two boundaries equally or unequally disposed about the true profile or entirely disposed on one side of the true profile. Profile tolerances apply normal (perpendicular) to the true profile at all points along the profile. The boundaries of the tolerance zone follow the geometric shape of the true profile. The actual surface or line element must be within the specified tolerance zone. Since the surface may lie anywhere within the profile boundary, the actual part contour could have abrupt surface variations. If this is undesirable, the drawing must indicate the design requirements, such as rate of change and/or blend requirements. Where a profile tolerance encompasses a sharp corner, the tolerance zone extends

**Fig. 8-1 Profile of a Surface Application (Unilaterally Outside)**

to the intersection of the boundary lines. See Fig. 8-12. Since the intersecting surfaces may lie anywhere within the converging zone, the actual part contour could be rounded. If this is undesirable, the drawing must indicate the design requirements, such as by specifying the maximum radius. See Fig. 8-5.

**8.3.1.1 Bilateral Profile Tolerance Zone.** The tolerance zone may be divided bilaterally to both sides of the true profile. Where an equally disposed bilateral tolerance is intended, it is necessary to show the feature control frame with a leader directed to the surface or an extension line of the surface, but not to the basic dimension.

**8.3.1.2 Unilateral and Unequally Disposed Profile Tolerance.** A unilateral and unequally disposed profile tolerance is indicated with an unequally disposed profile symbol placed in the feature control frame. See Fig. 3-11. The unequally disposed symbol is placed in the feature control frame following the tolerance value. A second value is added following the unequally disposed symbol to indicate the tolerance in the direction that would allow additional material to be added to the true profile.

(a) *Unilateral Tolerance in the Direction That Adds Material.* Where a unilateral profile tolerance is 0.3 and applies from the true profile in the direction that adds material, the tolerance value would be 0.3 and the value following the unequally disposed symbol would be 0.3. See Fig. 8-1.

(b) *Unilateral Tolerance in the Direction That Removes Material.* Where a unilateral profile tolerance is 0.3 and

applies from the true profile in the direction that removes material, the tolerance value would be 0.3, and the value following the unequally disposed symbol would be 0. See Fig. 8-2.

(c) *Unequally Disposed Tolerance.* Where an unequally disposed profile tolerance is 0.3, 0.1 applies from the true profile in the direction that adds material, and 0.2 applies from the true profile in the direction that removes material, the tolerance value would be 0.3, and the value following the unequally disposed symbol would be 0.1. See Fig. 8-3.

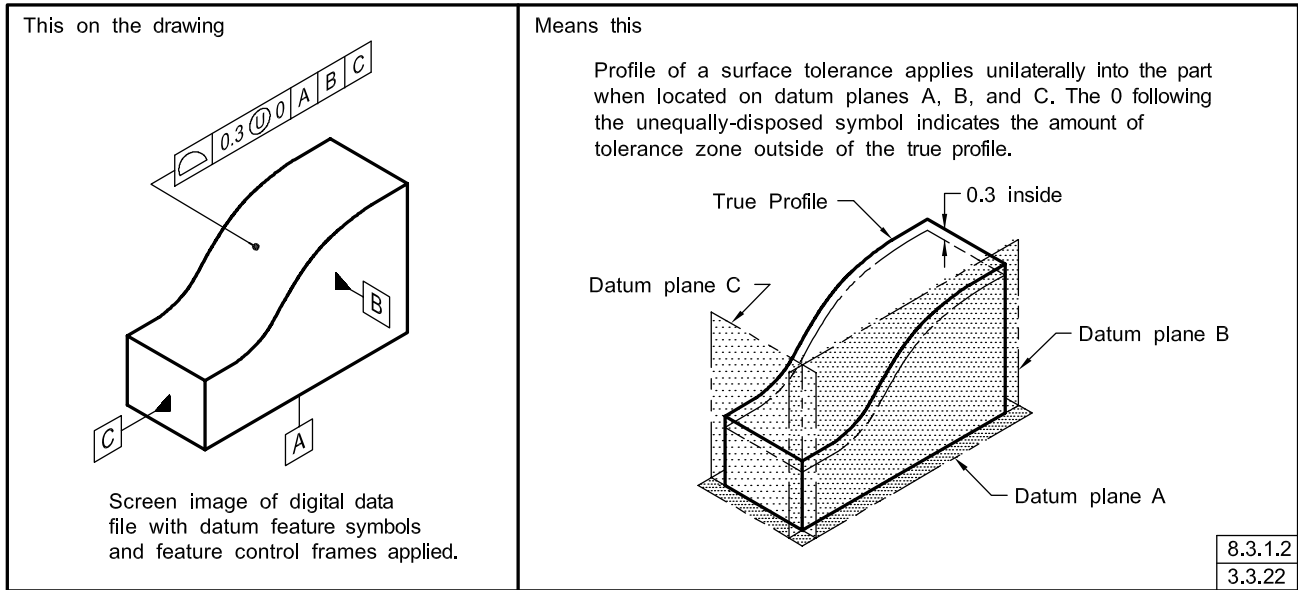
### 8.3.1.3 Indication of Tolerance Zones on 2D Drawings.

In orthographic 2D drawing views, as an alternate to using the unequally disposed profile symbol, it is permissible to indicate an unequally disposed or unilateral tolerance by showing graphically the distribution of the appropriate tolerance zone. Phantom lines are drawn parallel to the true profile to indicate the tolerance zone boundary. One end of the dimension line is extended to the feature control frame. The phantom line should extend only a sufficient distance to make its application clear. See Fig. 8-4.

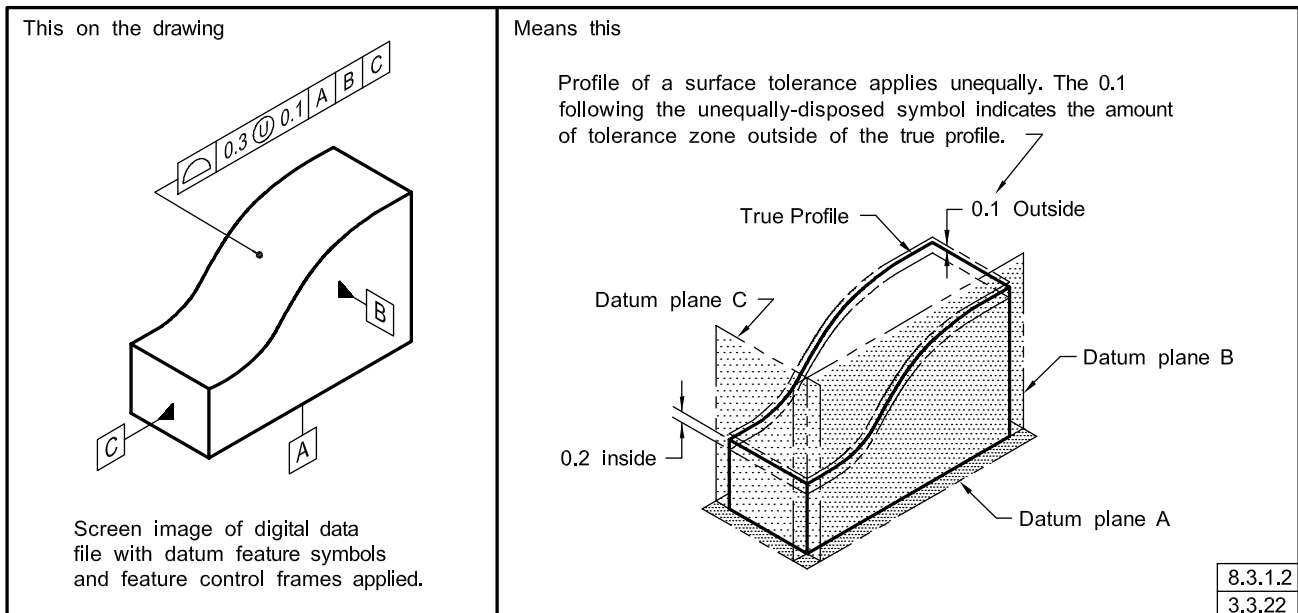
### 8.3.1.4 All Around Specification.

Where a profile tolerance applies all around the true profile of the designated features of the part (in the view where it is specified), the all-around symbol is placed on the leader from the feature control frame. See Fig. 8-5. The all-around symbol shall not be applied in an axonometric view on a 2D drawing. Where the requirement is that the tolerance applies all over a part, the all over application is used. See para. 8.3.1.6.

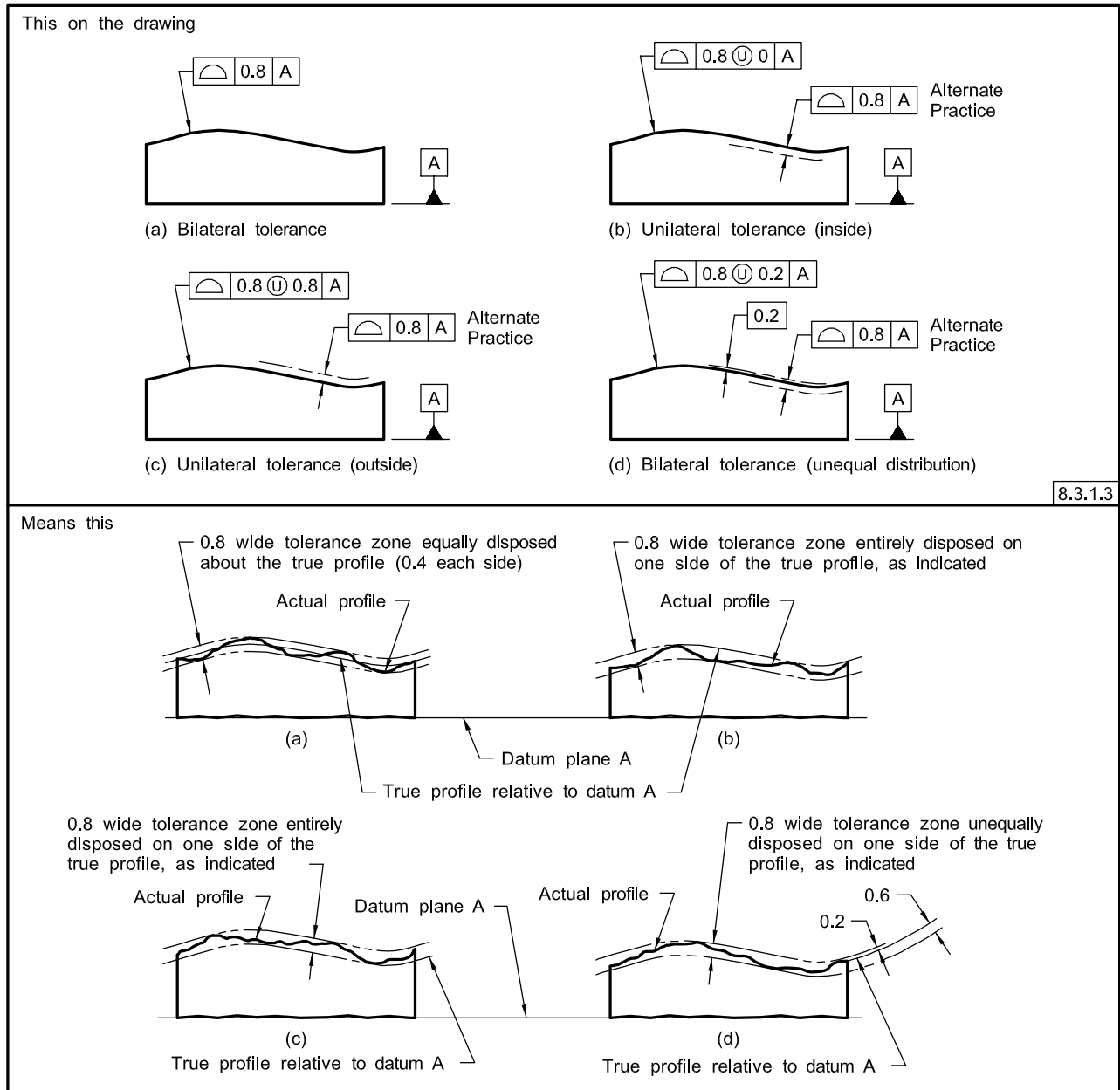
**Fig. 8-2 3D Profile of a Surface Application (Unilaterally Inside)**



**Fig. 8-3 3D Profile of a Surface Application (Unequally Disposed)**



**Fig. 8-4 Application of Profile of a Surface Tolerance to a Basic Contour**



**8.3.1.5 Limited Segment of a Profile.** Where segments of a profile have different tolerances, the extent of each profile tolerance may be indicated by the use of reference letters to identify the extremities or limits of each requirement accompanied with the use of the between symbol with each profile tolerance. See Fig. 8-6. Similarly, if some segments of the profile are controlled by a profile tolerance and other segments by individually tolerated dimensions, the extent of the profile tolerance shall be indicated. See Fig. 8-7.

**8.3.1.6 All-Over Specification.** A profile tolerance may be applied all over the 3-dimensional profile of a part unless

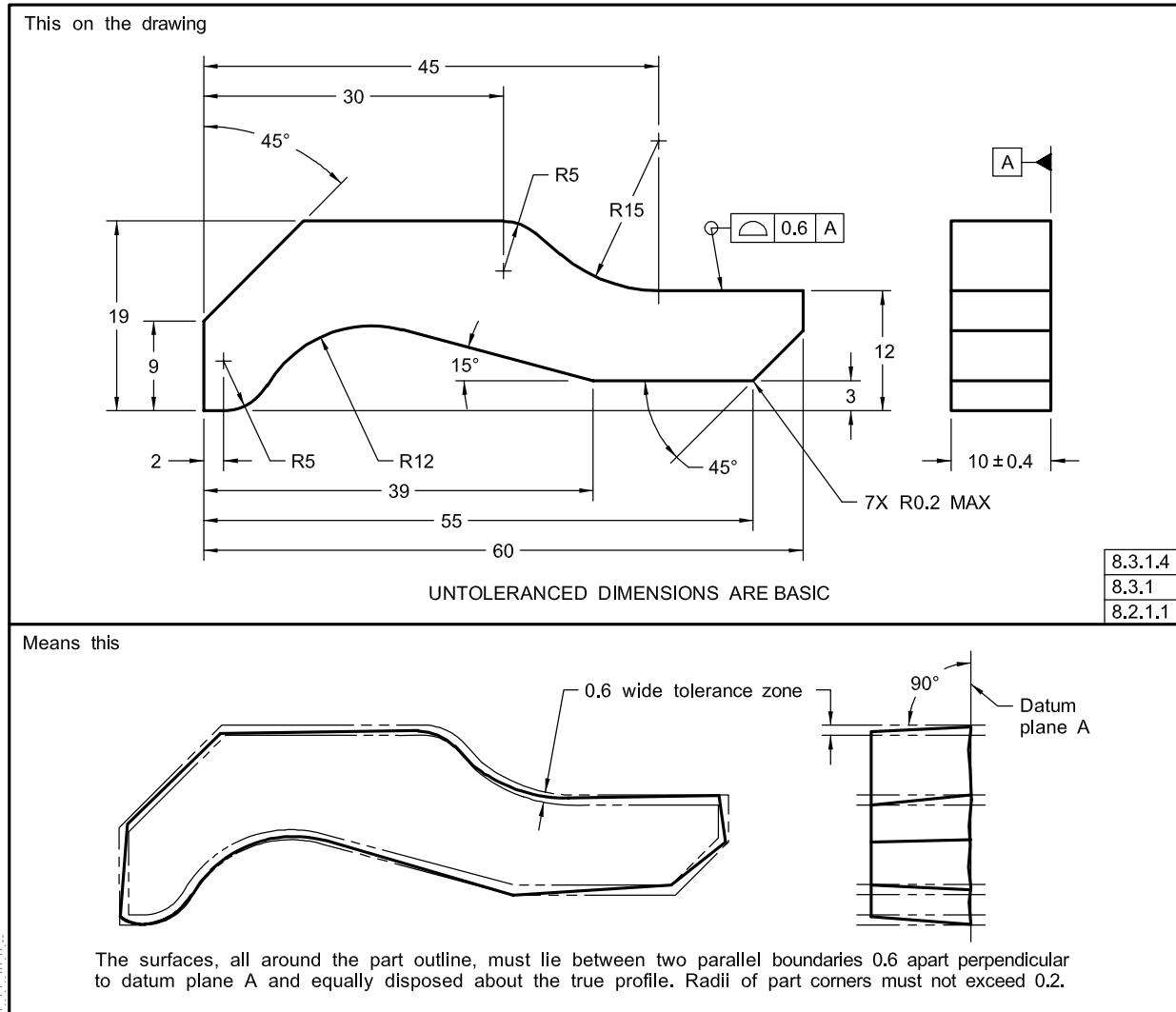
otherwise specified. It may be applied in one of the following ways:

- Place the “all over” symbol on the leader from the feature control frame as shown in Fig. 8-8.
- Place the term “ALL OVER” beneath the feature control frame.

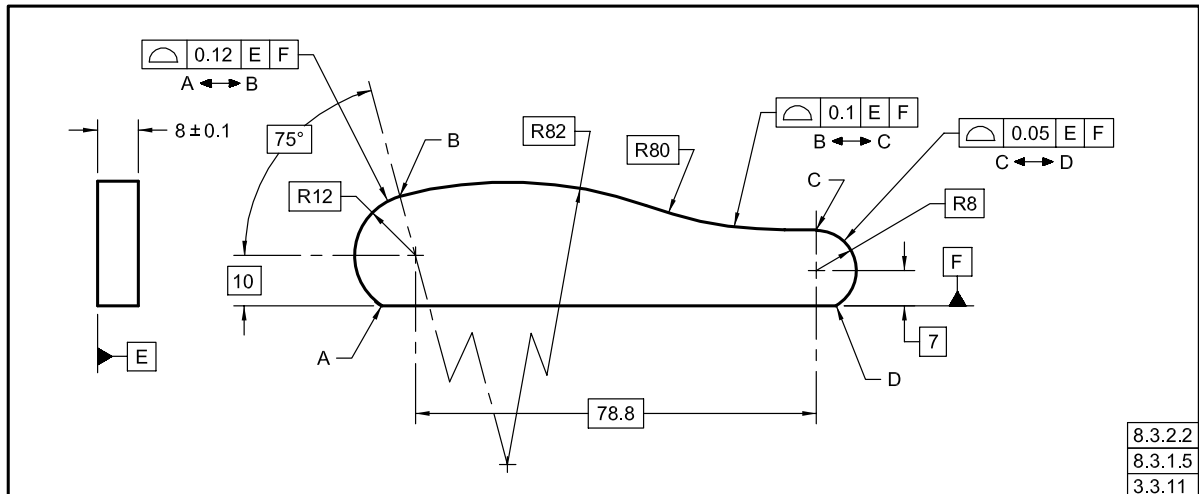
**8.3.2 Non-Uniform Zone**

A non-uniform tolerance zone is a maximum material boundary and a least material boundary, of unique shape, that encompasses the true profile. These boundaries are defined in a CAD file or by basic dimensions

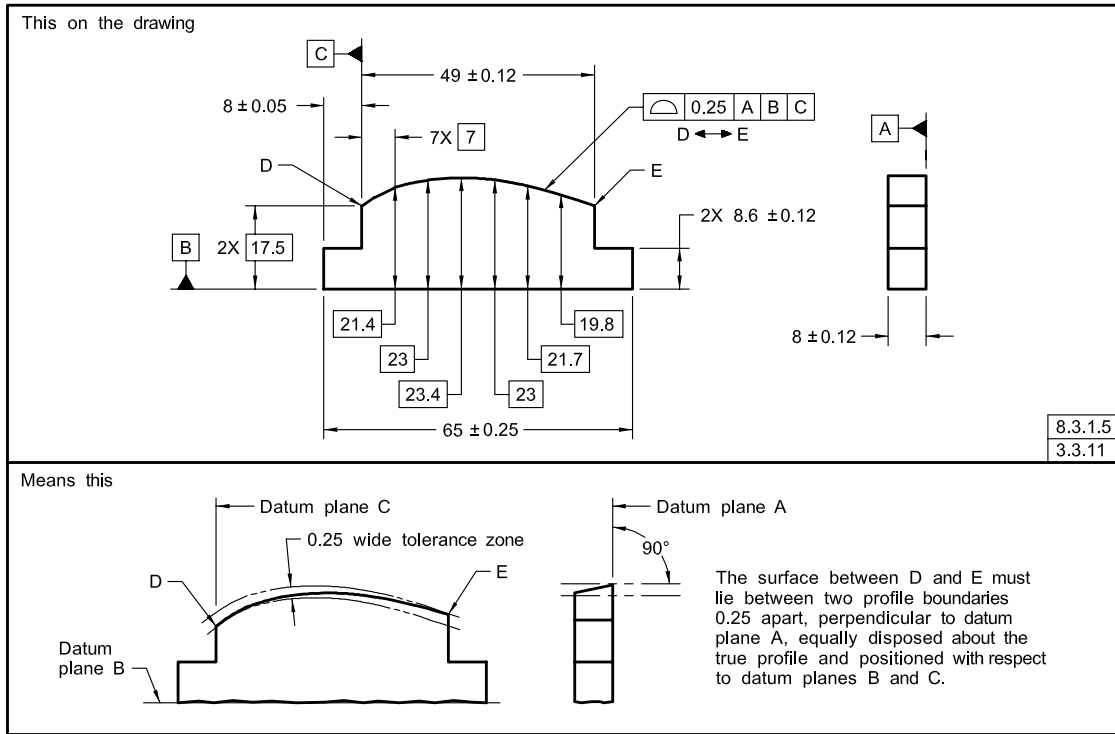
**Fig. 8-5 Specifying Profile of a Surface All Around**



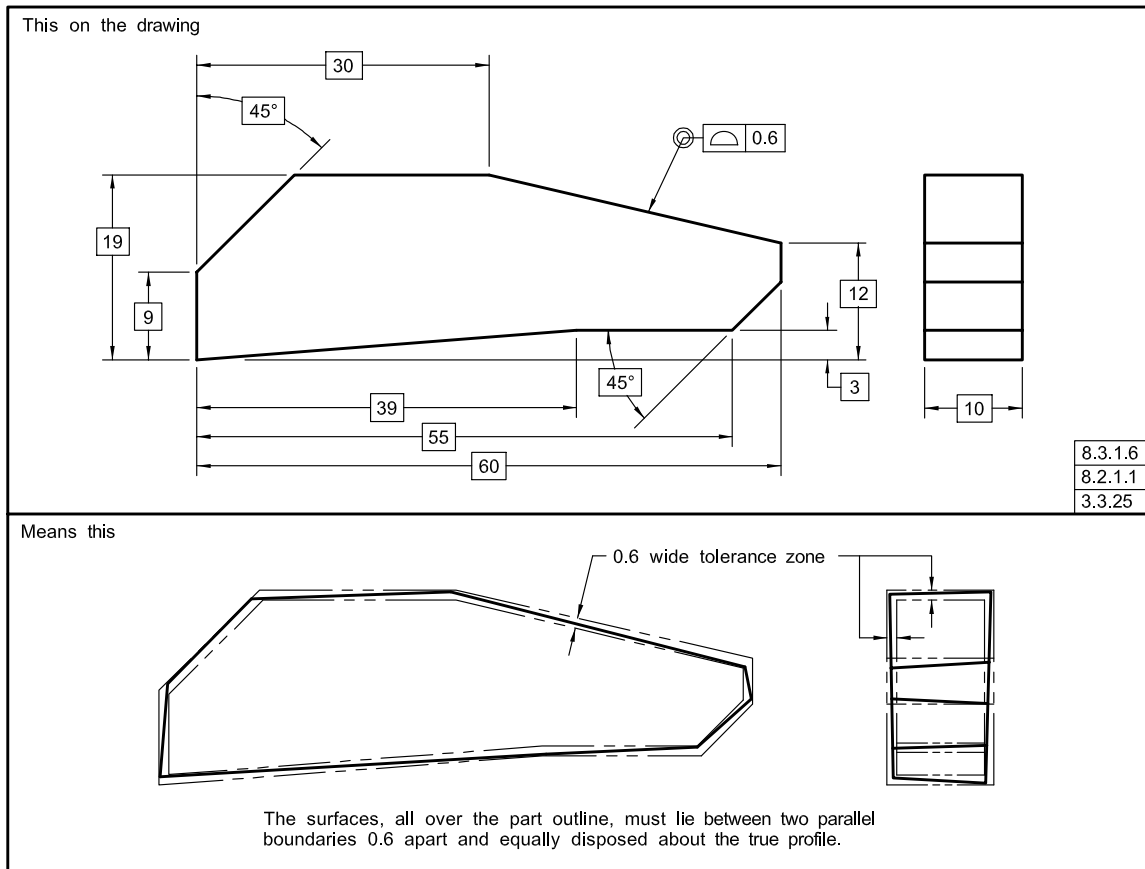
**Fig. 8-6 Specifying Different Profile Tolerances on Segments of a Profile**



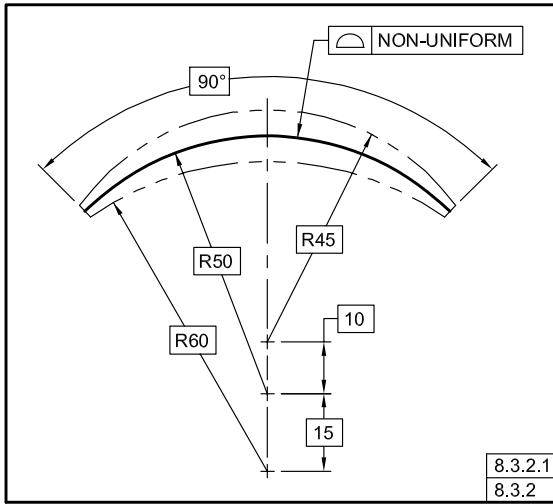
**Fig. 8-7 Specifying Profile of a Surface Between Points**



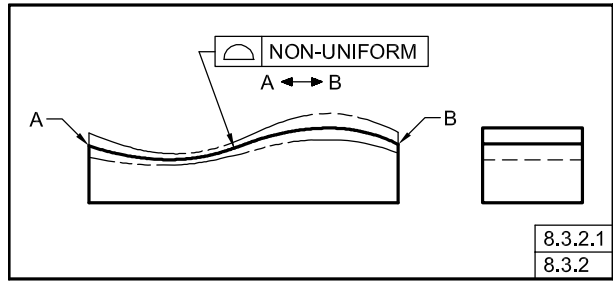
**Fig. 8-8 Specifying Profile of a Surface All Over**



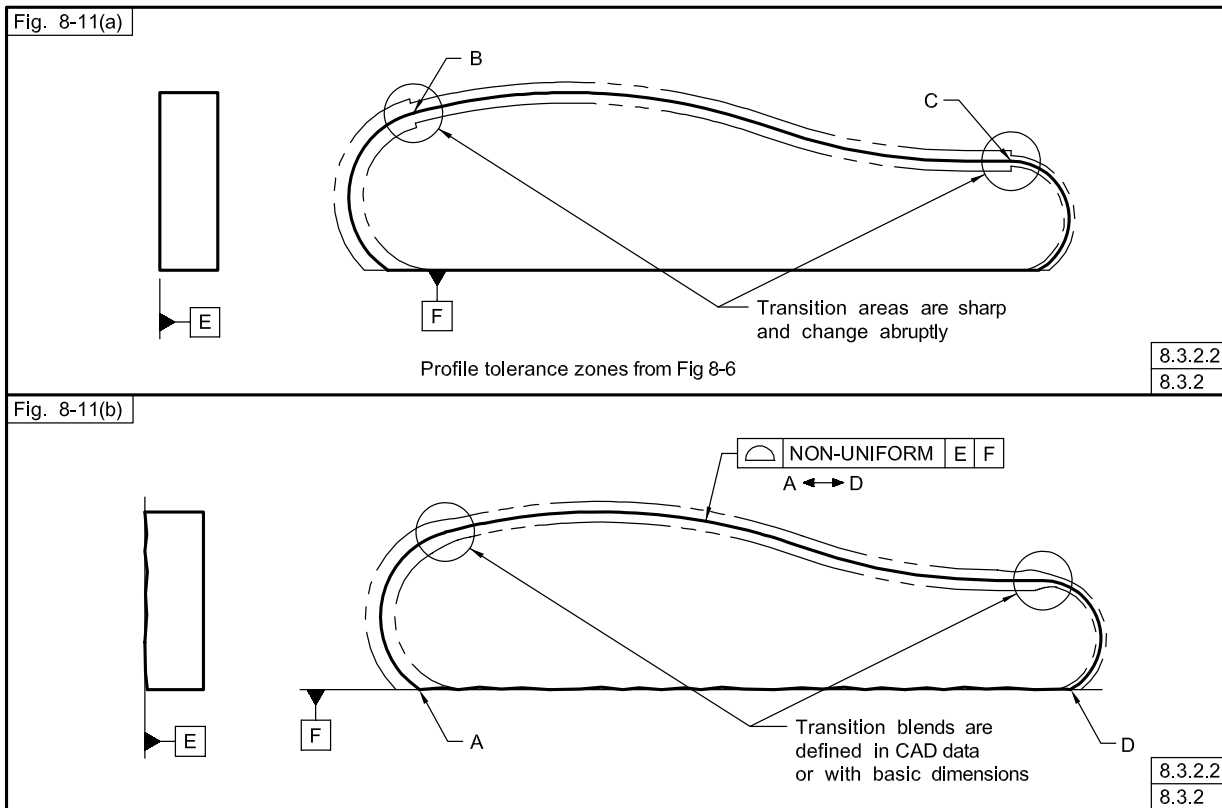
**Fig. 8-9 Non-Uniform Profile Tolerance Zone**



**Fig. 8-10 Non-Uniform Profile Tolerance Zone**



**Fig. 8-11 Non-Uniform Profile Tolerance Zone**



on a drawing with phantom lines to indicate the tolerance zone. The term “NON-UNIFORM” replaces the tolerance value within the feature control frame. See Figs. 8-9, 8-10, and 8-11.

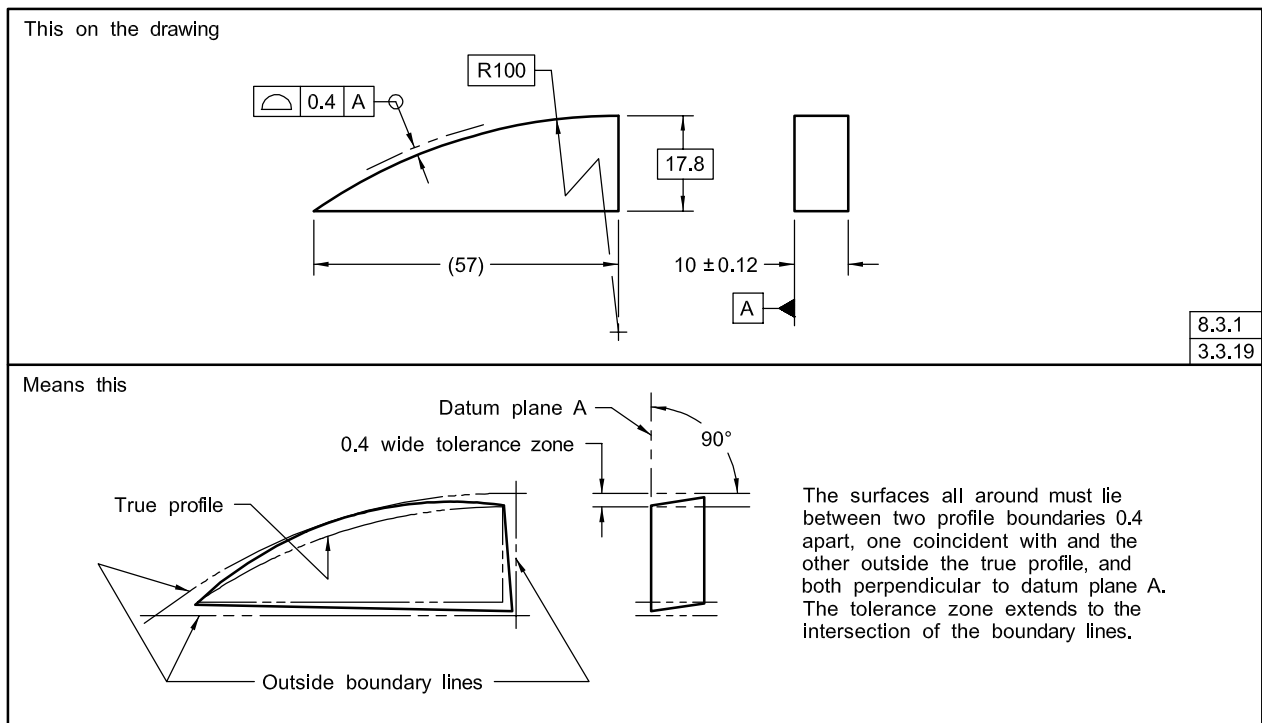
**8.3.2.1 Drawing Indication.** For the non-uniform tolerance zone, the leader line from the feature control frame is directed to the true profile. See Fig. 8-9.

Where individual segments of a profile are tolerated, the extent of each profile segment may be indicated by use of reference letters to identify the extremities or limits of each segment. See Fig. 8-10.

**8.3.2.2 Non-Uniform Zones to Smooth the Transitions.** Figure 8-11, illustration (a) shows the tolerance zones for Fig. 8-6. This figure illustrates abrupt transitions that occur



Fig. 8-12 Specifying Profile of a Surface for Sharp Corners



at the transition points B and C when different profile tolerances are specified on adjoining segments of a feature. A nonuniform profile tolerance zone may be used to smooth the transition areas. See Fig. 8-11, illustration (b).

NOTE: A profile per unit length, similar to that shown in Fig. 5-4 for the control of straightness, may be used to control abrupt transitions that occur when profile tolerances are specified on adjoining segments of a feature.

## 8.4 PROFILE APPLICATIONS

Applications of profile tolerancing are described in the following paragraphs.

### 8.4.1 Profile Tolerance for Plane Surfaces

Profile tolerancing may be used to control form, orientation, and location of plane surfaces. In Fig. 8-13, a profile of a surface is used to control a plane surface inclined to two datum features.

**8.4.1.1 Coplanarity.** Coplanarity is the condition of two or more surfaces having all elements in one plane. A profile of a surface tolerance may be used where it is desired to treat two or more surfaces as a single interrupted or noncontinuous surface. In this case, a control is provided similar to that achieved by a flatness tolerance applied to a single plane surface. As shown in Fig. 8-14, the profile of a surface tolerance establishes a tolerance

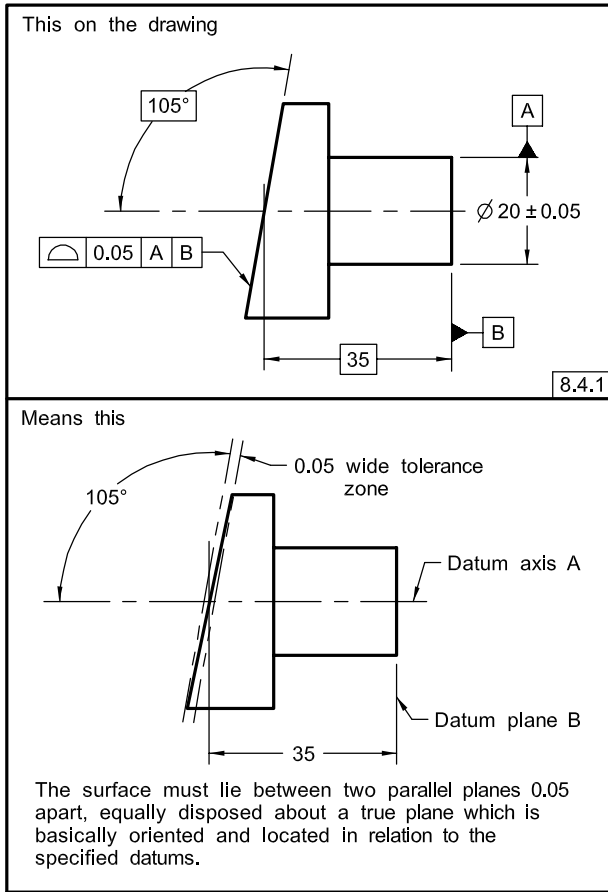
zone defined by two parallel planes within which the considered surfaces must lie. As in the case of flatness, no datum reference is stated. Where two or more surfaces are involved, it may be desirable to identify which specific surface(s) are to be used as the datum feature(s). Datum feature symbols are applied to these surfaces with the appropriate tolerance for their relationship to each other. The datum reference letters are added to the feature control frame for the features being controlled. See Fig. 8-15.

**8.4.1.2 Offset Surfaces.** A profile of a surface tolerance may be used where it is desired to control two or more offset surfaces to each other. The feature control frame is associated with the applicable surfaces. The desired offset is shown with a basic dimension. See Fig. 8-16.

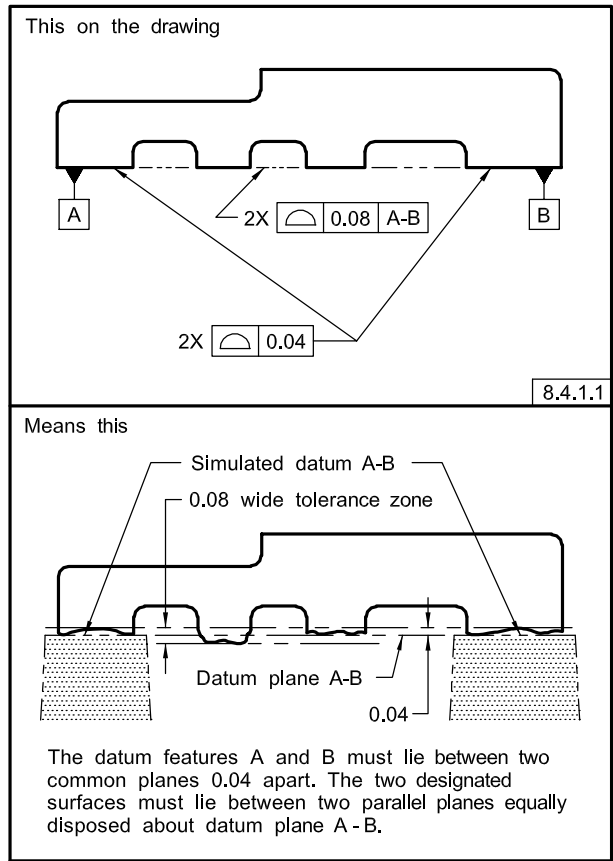
### 8.4.2 Conicity

A profile tolerance may be specified to control the conicity of a surface in two ways: as an independent control of form as in Fig. 8-17, or as combinations of size, form, orientation, and location, as in Fig. 8-18. Figure 8-17 depicts a conical feature controlled by a profile of a surface tolerance where conicity of the surface is a refinement of size. In Fig. 8-18, the same control is applied but is oriented to a datum axis. In each case, the feature must be within size limits.

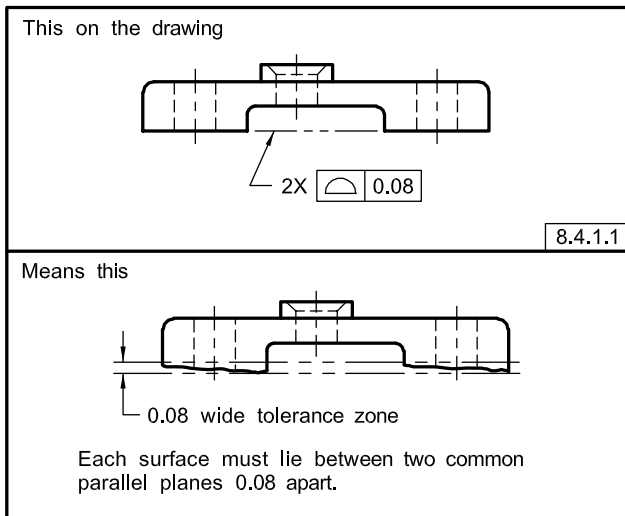
**Fig. 8-13 Specifying Profile of a Surface for a Plane Surface**



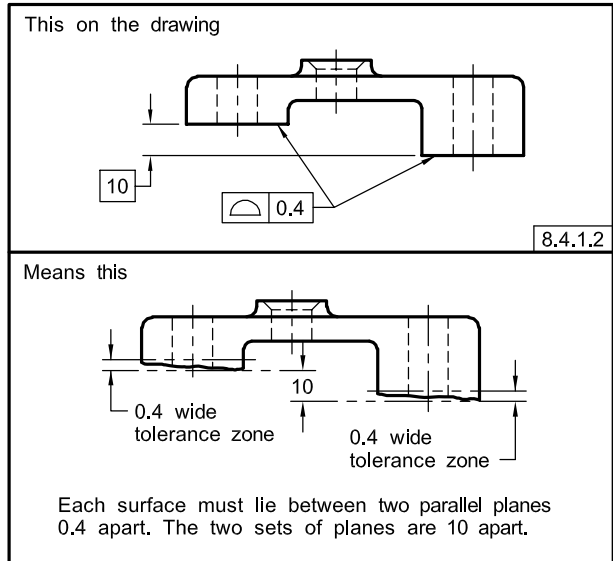
**Fig. 8-15 Specifying Profile of a Surface for Coplanar Surfaces to a Datum Established by Two Surfaces**



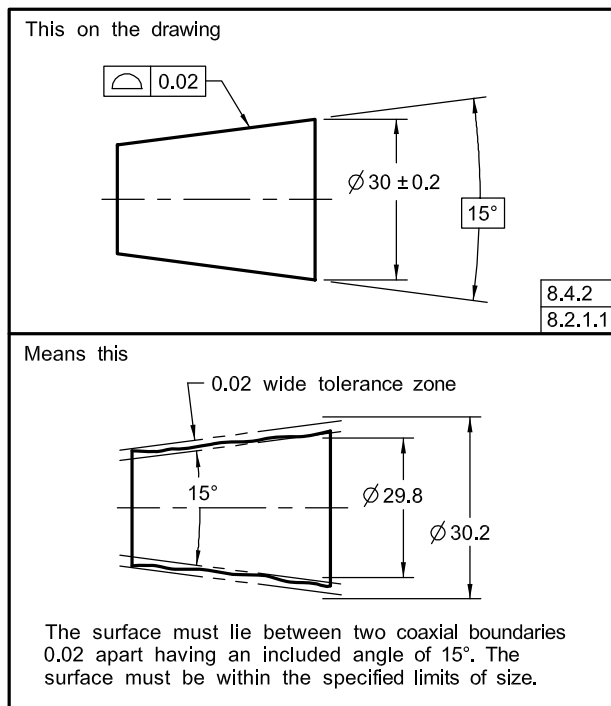
**Fig. 8-14 Specifying Profile of a Surface for Coplanar Surfaces**



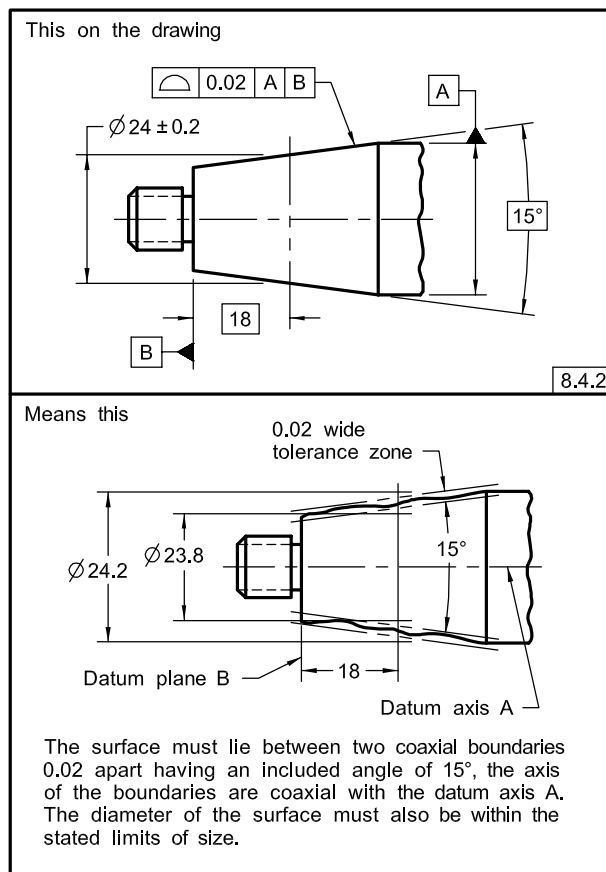
**Fig. 8-16 Specifying Profile of a Surface for Stepped Surfaces**



**Fig. 8-17 Specifying Profile of a Conical Feature**



**Fig. 8-18 Profile Tolerancing of a Conical Feature, Datum Related**



**8.5 MATERIAL CONDITION AND BOUNDARY CONDITION MODIFIERS AS RELATED TO PROFILE CONTROLS**

Since profile control is used primarily as a surface control, “regardless of feature size” is the default condition on a size feature application. MMB and LMB application (modifiers) is only permissible on the datum feature references. See Figs. 4-31, 4-39, and 7-55.

**8.6 COMPOSITE PROFILE**

Where design requirements permit a feature locating tolerance zone to be larger than the tolerance zone that controls the feature size and form, a composite profile tolerance may be used.

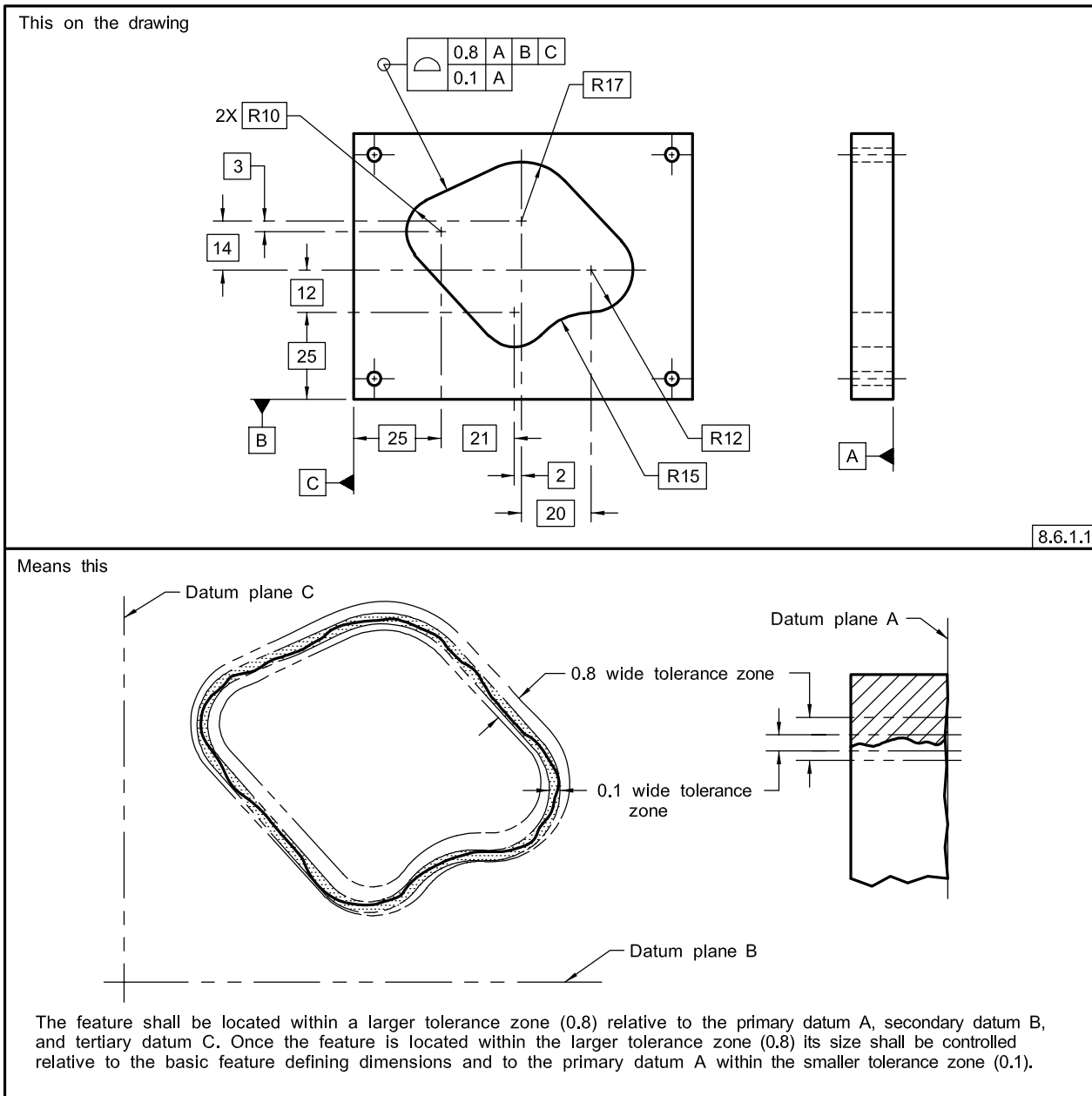
**8.6.1 Composite Profile Tolerancing for a Single Feature**

This method provides a composite application of profile tolerancing for location of a profiled feature as well as the requirement of various combinations of form, orientation, and size of the feature within the larger profile locating tolerance zone. Requirements are annotated by the use of a composite profile feature control frame similar to that shown in Fig. 3-26, illustration (a). Each complete horizontal segment of a composite profile feature control frame constitutes a separately verifiable component of multiple interrelated requirements. The profile symbol is entered once and is applicable to all horizontal segments. The upper segment is referred

to as the profile locating control. It specifies the larger profile tolerance for the location of the profiled feature. Applicable datums are specified in a desired order of precedence. The lower segments are referred to as profile feature controls. Each segment specifies a progressively smaller profile tolerance than the preceding segment.

**8.6.1.1 Explanation of Composite Profile Tolerance for a Single Feature.** Figure 8-19 contains an irregular shaped feature with a composite profile tolerance applied. The toleranced feature is located from specified datums by basic dimensions. Datum referencing in the upper segment of a composite profile feature control frame serves to locate the profile locating tolerance zone relative to specified datums. See Fig. 8-19. Datum referencing in the lower segment serves to establish the limits of size, form, and orientation of the profile feature, relative to the datums specified. See Figs. 8-20 and 8-21. The tolerance values represent the distance between two boundaries disposed about the true profile with respect to the applicable datums. The actual surface of the controlled feature must lie within both the profile locating tolerance zone and the profile feature tolerance zone.

**Fig. 8-19 Composite Profile Tolerancing of an Irregular Feature**



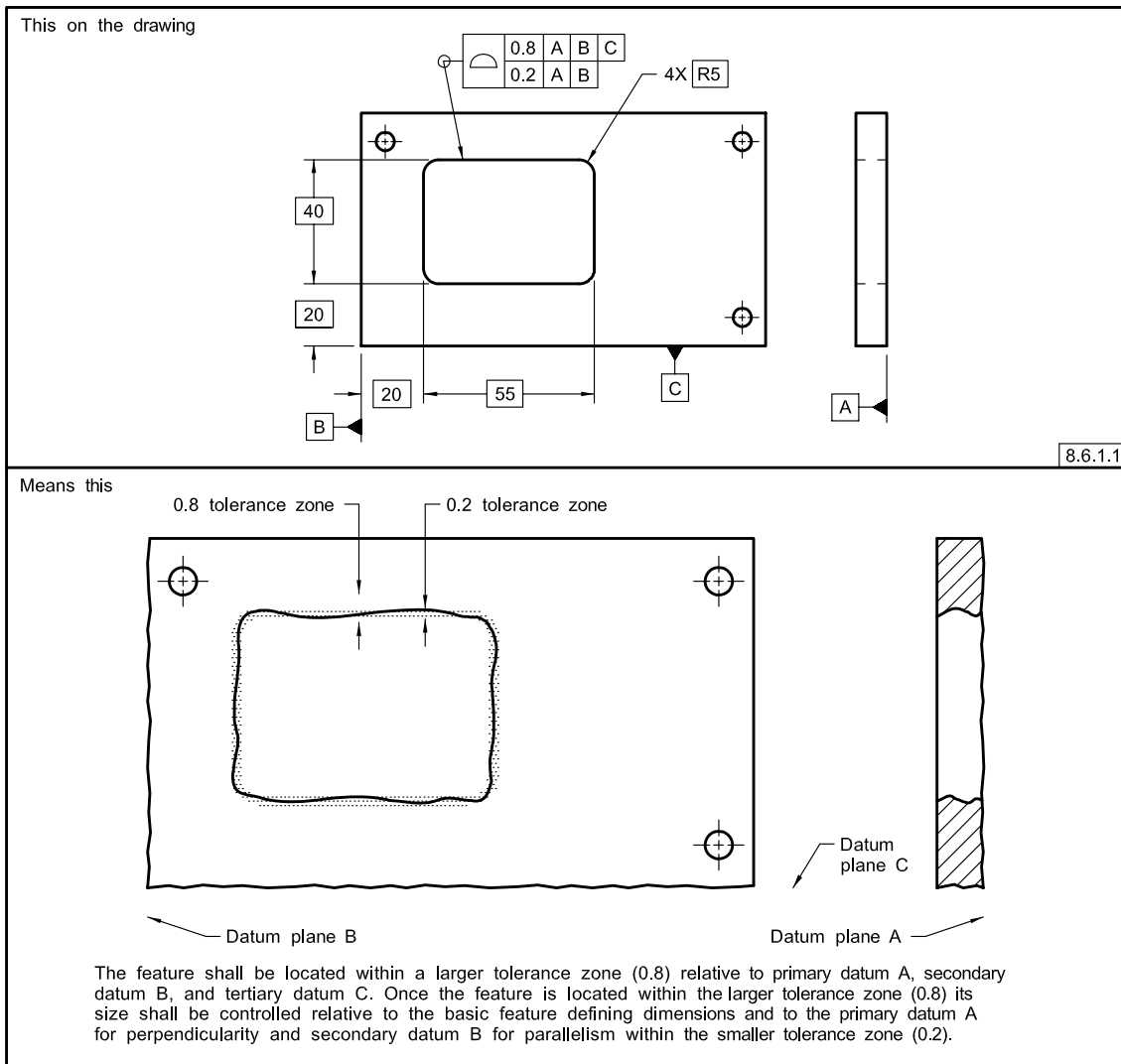
**8.6.1.2 Composite Profile Tolerancing for Multiple Features (Feature Pattern Location).** Where design requirements for a pattern of features permit a profile Feature-Relating Tolerance Zone Framework (FRTZF) to be located and oriented within limits imposed upon it by a profile Pattern-Locating Tolerance Zone Framework (PLTZF), composite profile tolerancing is used.

**8.6.1.3 Explanation of Composite Profile Tolerancing for Multiple Features.** This provides a composite application of profile tolerancing for the location and constraint (rotation and translation) of a feature pattern (PLTZF) as well as the interrelation (location, size, form,

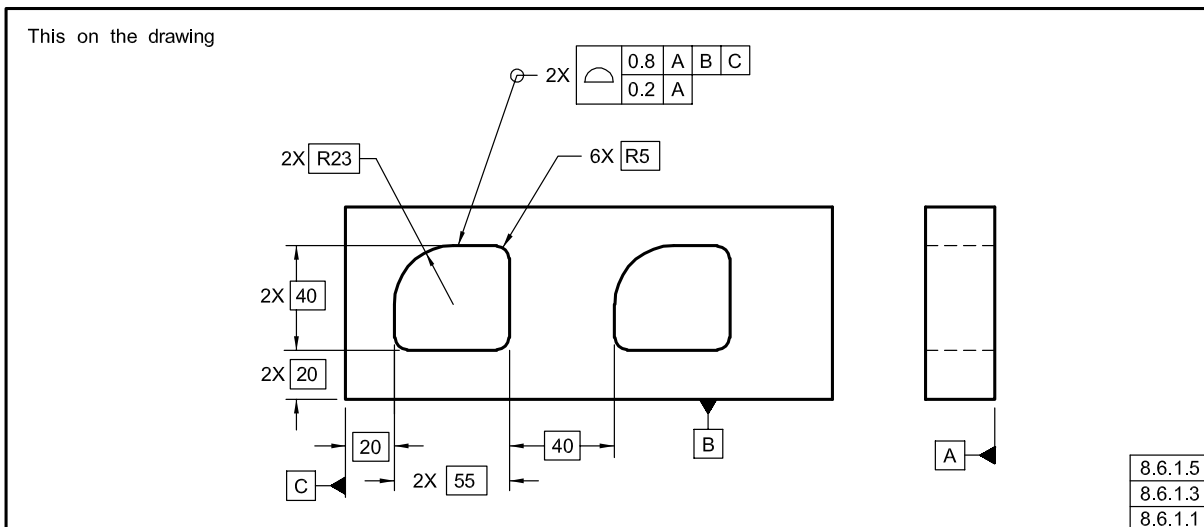
orientation) of profiled features within these patterns (FRTZF). Requirements are annotated by the use of a composite feature control frame. The profile symbol is entered once and is applicable to each horizontal segment. Each horizontal segment in the feature control frame may be verified separately. See Fig. 8-21.

(a) *Pattern-Locating Tolerance Zone Framework (PLTZF).* Where composite controls are used, the uppermost segment is the pattern-locating control. The PLTZF is constrained in rotation and translation relative to the specified datums. It specifies the larger profile tolerance for the location of the pattern of profiled features as a group. Applicable datum features are referenced in the desired

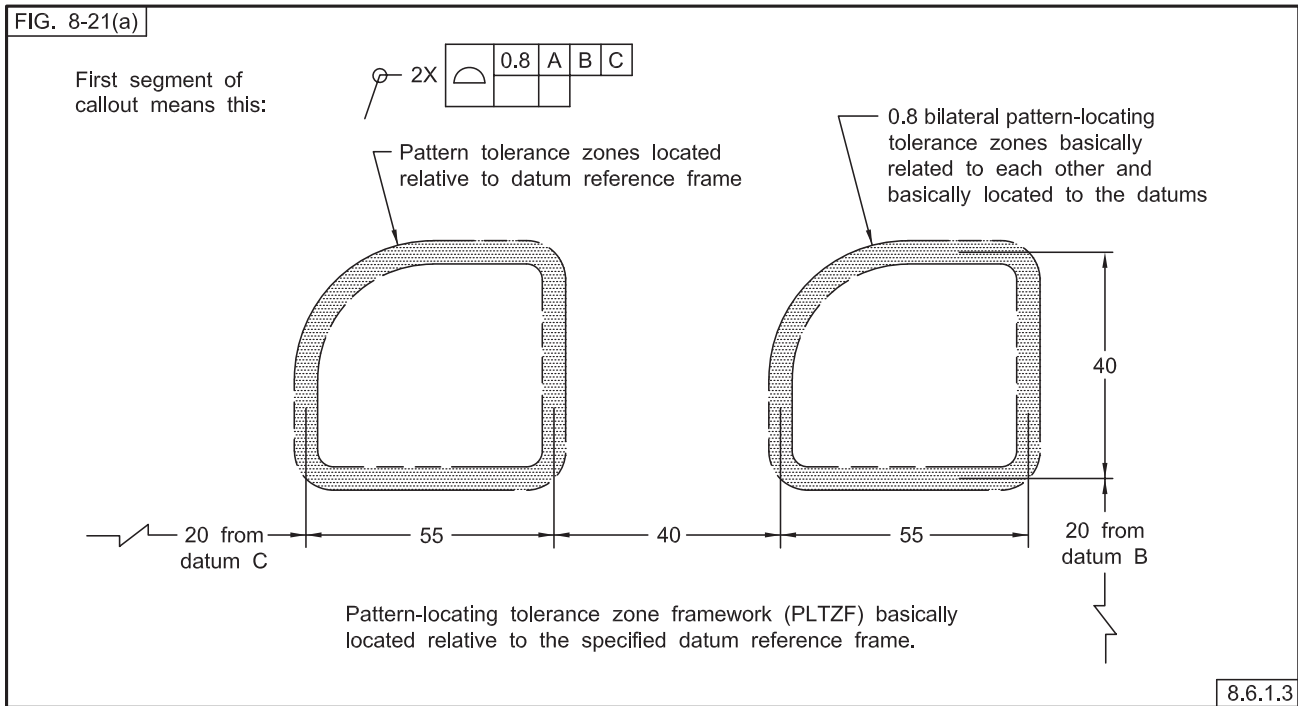
**Fig. 8-20 Composite Profile Tolerancing of a Feature**



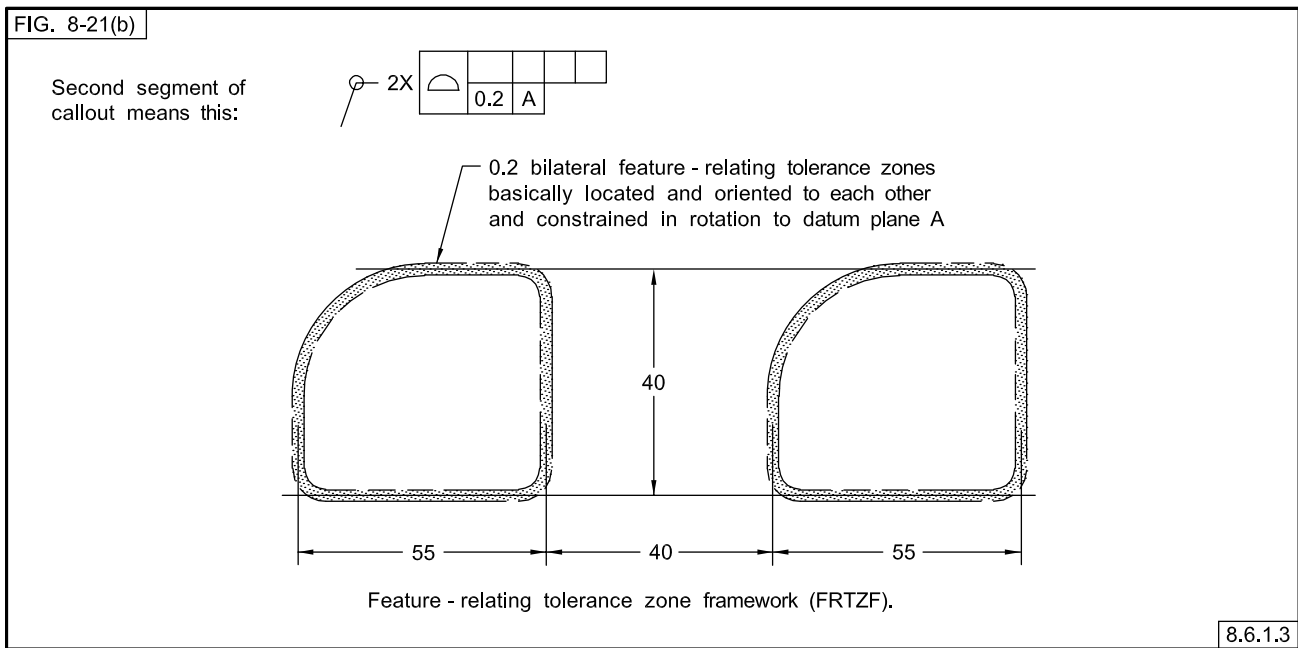
**Fig. 8-21 Pattern Located by Composite Profile Tolerancing**



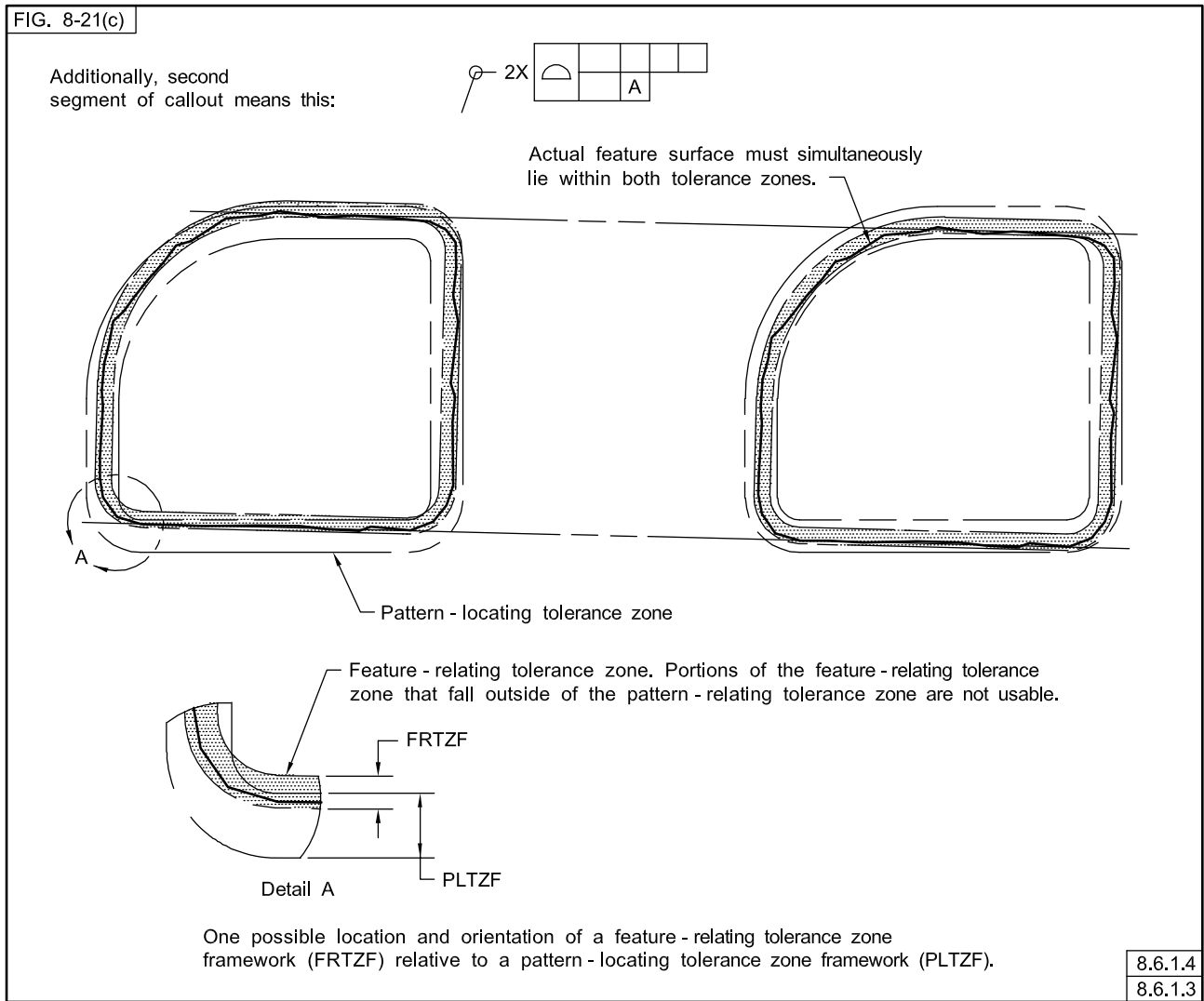
**Fig. 8-21 Pattern Located by Composite Profile Tolerancing (Cont'd)**



**Fig. 8-21 Pattern Located by Composite Profile Tolerancing (Cont'd)**



**Fig. 8-21 Tolerance Zones for Composite Profile Pattern (Cont'd)**



order of precedence, and serve to relate the PLTZF to the datum reference frame. See Figs. 8-21, illustration (a) and 8-22, illustration (a).

(b) *Feature-Relating Tolerance Zone Framework (FRTZF)*. Each of the lower segments is referred to as the profile feature-relating control. They govern the smaller tolerance for size, form, orientation, and location within the pattern of features and may include constraints on rotation of a FRTZF to specified datums. Basic location dimensions used to relate the PLTZF to specified datums are not applicable to the location of any FRTZF. The tolerated feature shall lie within both the PLTZF and the FRTZF. See Figs. 8-21, illustration (b) and 8-22, illustration (b).

(1) Where datum references are not specified in a lower segment of the composite feature control frame,

the FRTZF is free to rotate and translate within the boundaries established and governed by the PLTZF.

(2) If datums are specified in the lower segment(s), they govern the rotation of the FRTZF relative to the datums and within the boundaries established and governed by the PLTZF. In some instances portions of the FRTZF may lie outside of the PLTZF and are not usable. See Figs. 8-21, illustration (c) and 8-22, illustration (b).

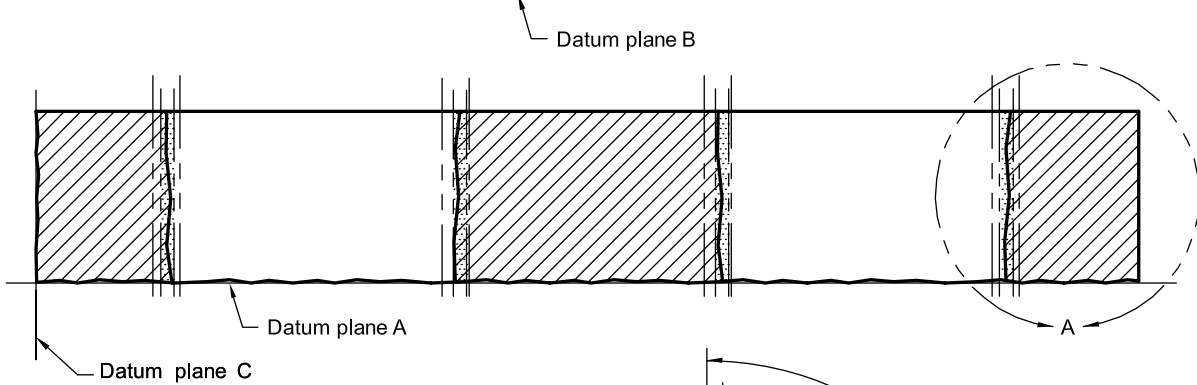
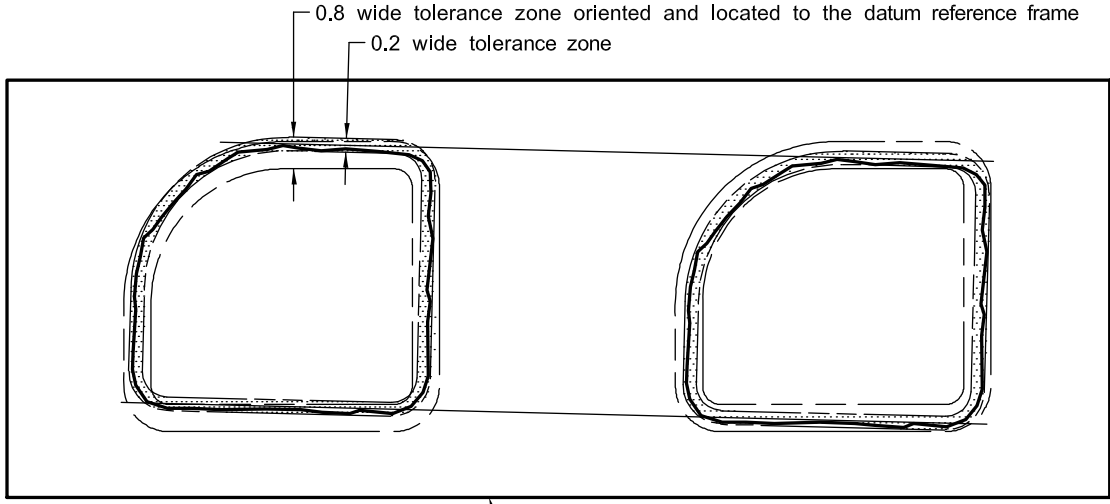
(3) Where datum references are specified, one or more of the datums specified in the upper segment of the frame are repeated, as applicable, and in the same order of precedence, to constrain rotation of the FRTZF.

(c) *Different Datum Reference Frame and Design Requirements*. If different datums, different datum modifiers, or the same datums in a different order of precedence are specified, this constitutes a different datum reference

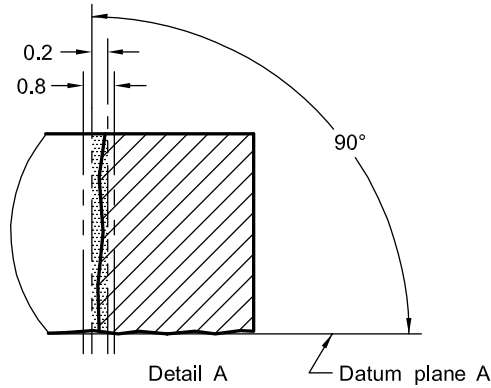
**Fig. 8-21 Tolerance Zones for Composite Profile Pattern (Cont'd)**

FIG. 8-21(d)

Additionally, second segment of callout means this:



Once the features are located within the 0.8 pattern - locating tolerance zone framework, their size and feature-relating location shall be controlled relative to the basic feature defining dimensions and to the primary datum A for perpendicularity within the 0.2 feature - relating tolerance zone.



8.6.1.4

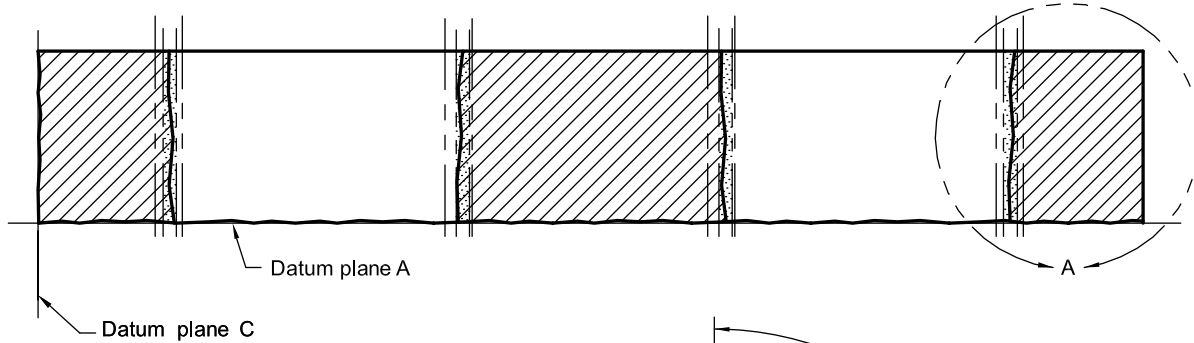
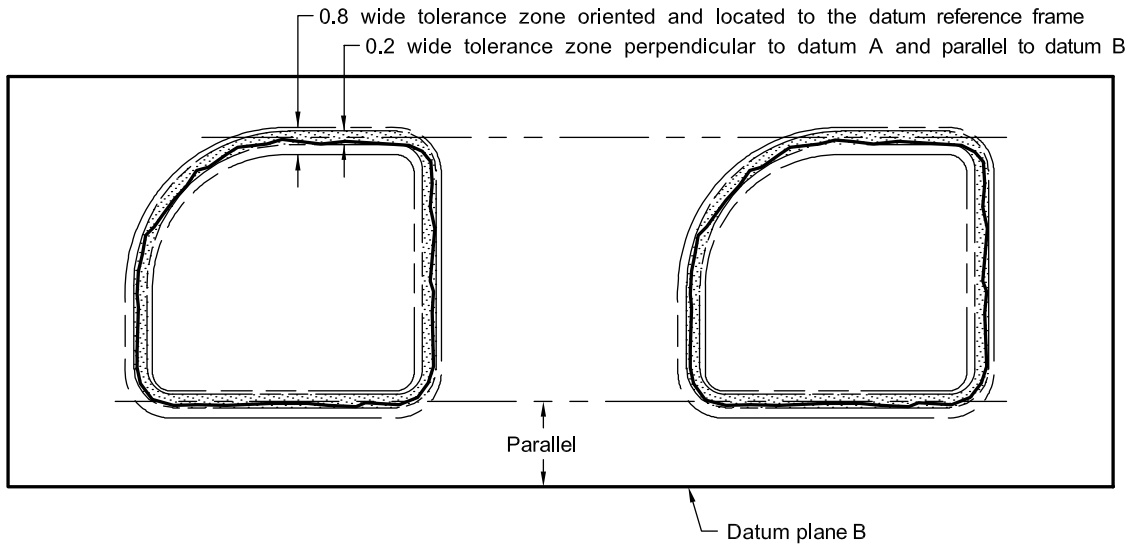
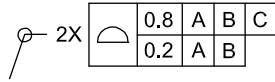




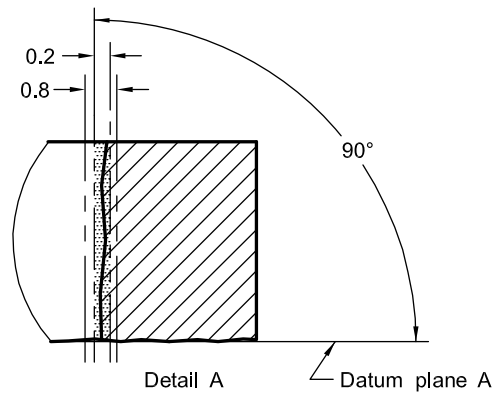
Fig. 8-22 Tolerance Zones for Composite Profile Pattern (Cont'd)

FIG. 8-22(b)

Additionally, second segment of callout means this:

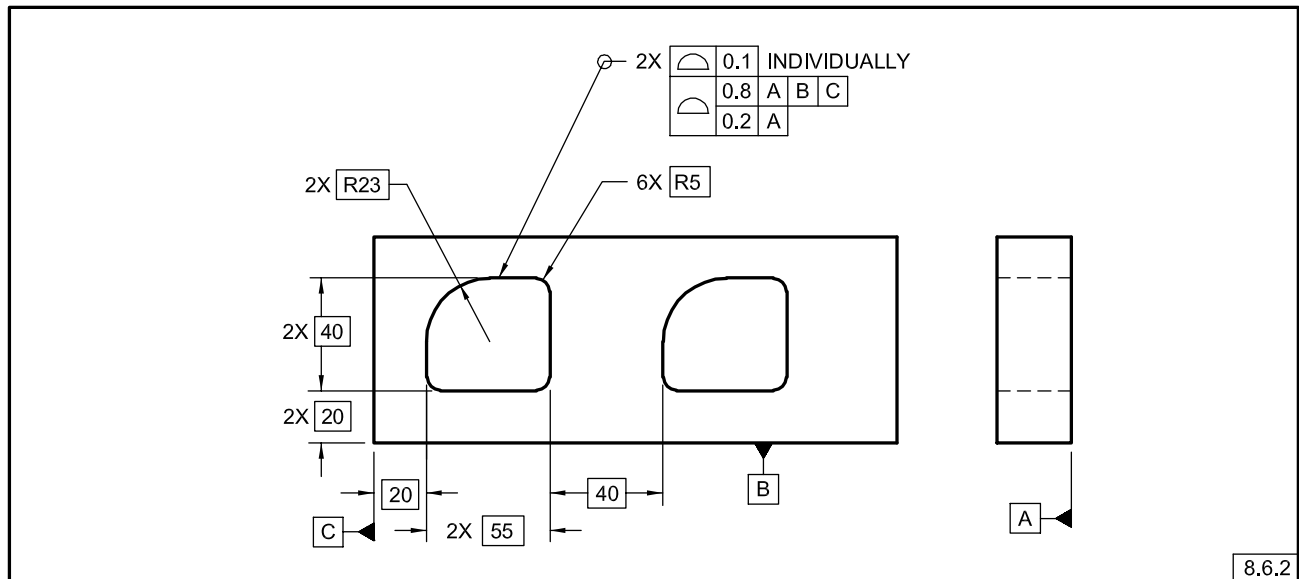


Once the features are located within the 0.8 pattern - locating tolerance zone framework, their size and feature-relating location shall be controlled relative to the basic feature defining dimensions and to the primary datum A for perpendicularity and secondary datum B for parallelism within the 0.2 feature - relating tolerance zone.



8.6.1.5  
8.6.1.3

**Fig. 8-23 Irregular-Shaped Feature With a Profile Size/Form Control and the Pattern Located by Composite Profile Tolerance**



frame and design requirements. This is not to be specified using the composite profile tolerancing method.

#### 8.6.1.4 Primary Datum Repeated in Lower Segment.

As can be seen from the sectional view of the tolerance zones in Fig. 8-21, illustration (d), since datum plane A has been repeated in the lower segment of the composite feature control frame, the profile zones of both the PLTZF and FRTZF are perpendicular to datum plane A and, therefore, parallel to each other. In certain instances, portions of the smaller zones may fall beyond the peripheries of the larger tolerance zones. However, these portions of smaller tolerance zones are not usable because the surface of the features must not violate the boundaries of the larger tolerance zones. See also Fig. 8-21, illustration (c). The profile of the actual feature may vary obliquely (out of perpendicularity) only within the confines of the respective smaller feature relating tolerance zones (FRTZF).

**8.6.1.5 Primary and Secondary Datums Repeated in Lower Segment.** Figure 8-22 repeats the feature patterns of Fig. 8-21. In Fig. 8-22, the lower segment of the composite feature control frame repeats datums A and B. Figure 8-22, illustrations (a) and (b), shows that the tolerance zones of the FRTZF may be translated from the true locations (as a group), as governed by the tolerance zones of the PLTZF, constrained in rotation by datum planes A and B. Figure 8-22, illustration (a) shows that the actual surfaces of the features must reside within both the tolerance zones of the FRTZF and the PLTZF.

#### 8.6.2 Composite Profile With Independent Size/Form Control

Where the design requires that the size and form of one or more features be controlled independently of the composite profile tolerance, a separate single segment profile feature control frame is used followed by the term **INDIVIDUALLY**. The size/form tolerance specified must be less than the tolerance in the lower segment (FRTZF) of the composite profile control. See Fig. 8-23.

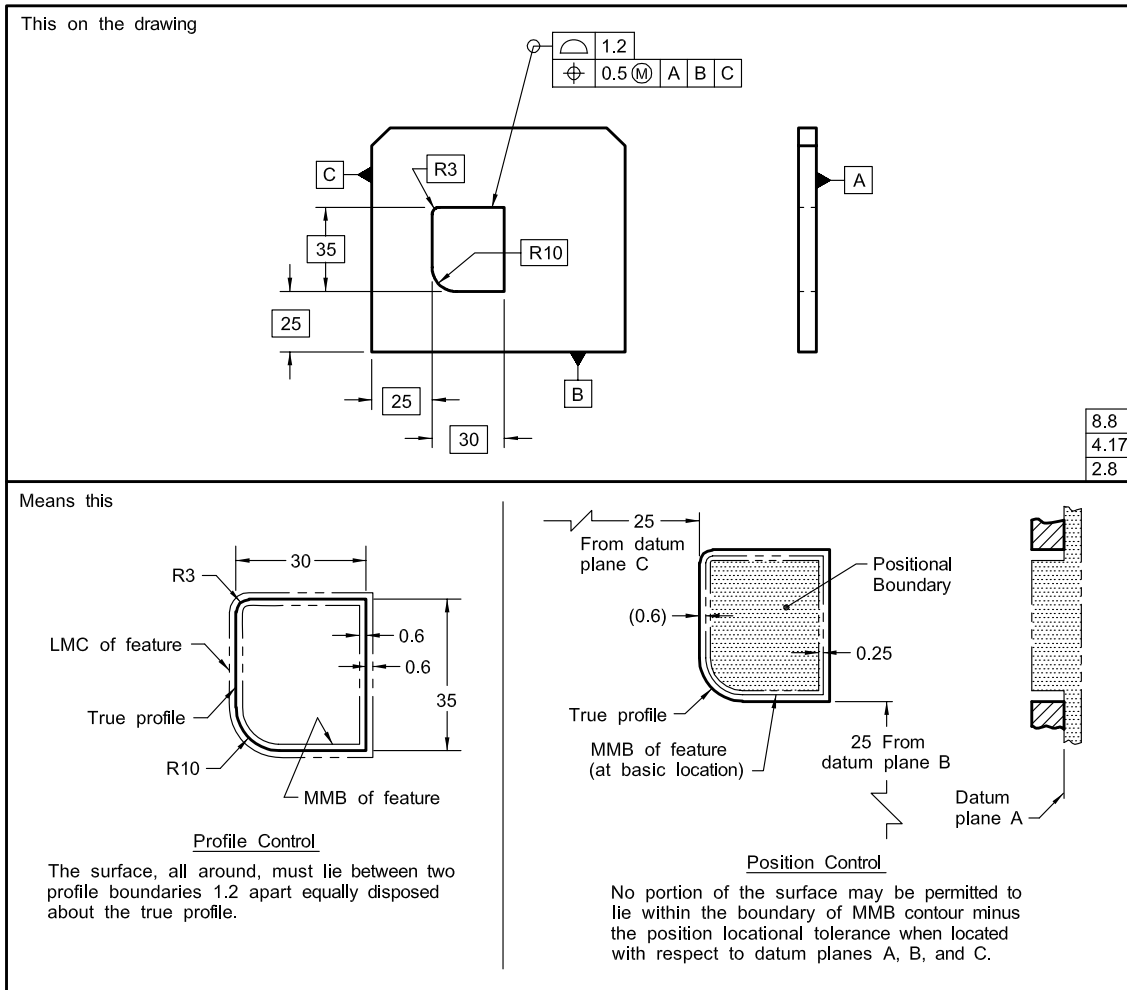
#### 8.7 MULTIPLE SINGLE-SEGMENT PROFILE TOLERANCING

For multiple single-segment profile tolerancing, datum feature references are interpreted the same as for multiple single-segment positional tolerancing. See para. 7.5.2.

#### 8.8 COMBINED CONTROLS

Profile tolerancing may be combined with other types of geometric tolerancing. Profile tolerancing may be combined with positional tolerancing where it is necessary to control the boundary of a noncylindrical feature. See Fig. 8-24. In this example the basic dimensions and the profile tolerance establish a tolerance zone to control the shape and size of the feature. Additionally, the positional tolerance establishes a theoretical boundary shaped identically to the true profile. For an internal feature the boundary equals the MMC size of the profile minus the positional tolerance, and the entire feature surface must

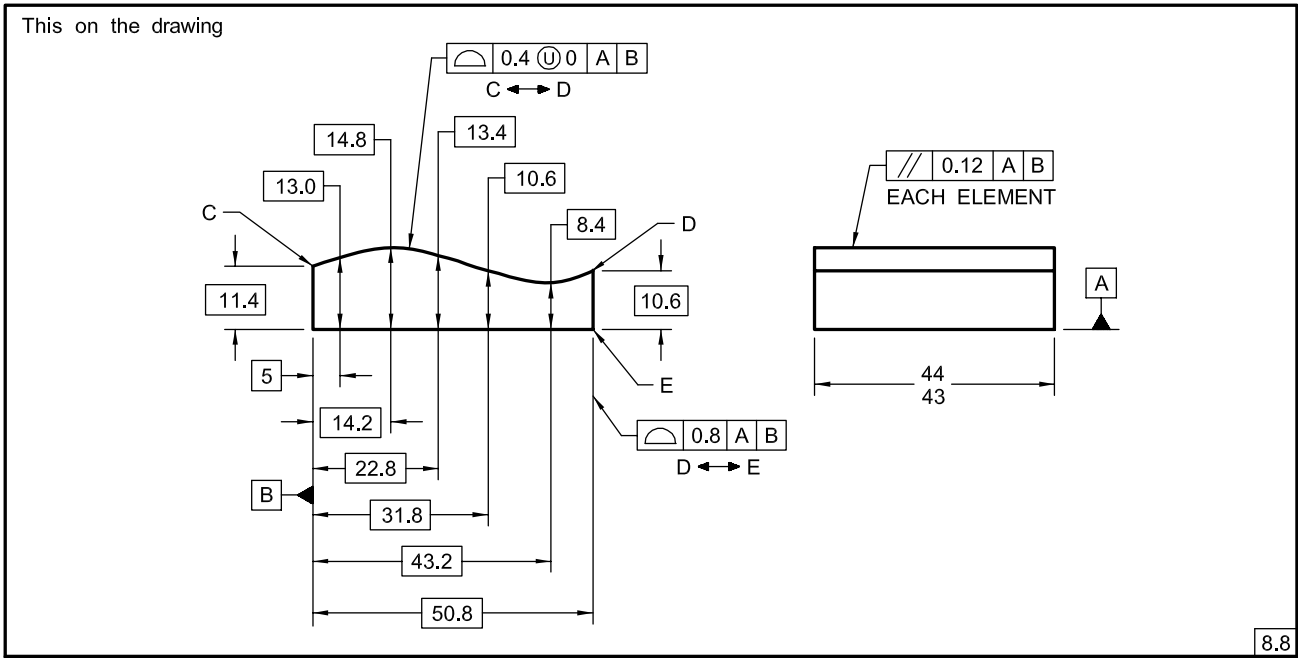
**Fig. 8-24 MMC Principle Used With Profile Controls**



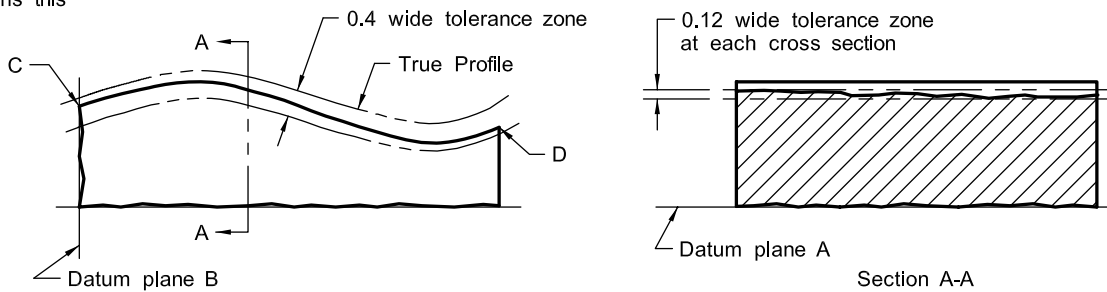
lie outside the boundary. For an external feature, the boundary equals the MMC size of the profile plus the positional tolerance, and the entire feature surface must lie within the boundary. The term **BOUNDARY** is optional and may be placed beneath the positional feature control frame. Figure 8-25 illustrates a surface that has a profile tolerance refined by a parallelism tolerance. The surface must not only be within the profile tolerance, but each straight line element of the surface must also be parallel to the datum within the tolerance specified. Figure 8-26

illustrates a surface that has a profile tolerance refined by a runout tolerance. The entire surface must be within the profile tolerance, and the circular elements must be within the specified runout tolerance. Figure 8-27 illustrates a part with a profile of a line tolerance where size is controlled by a separate tolerance. Line elements of the surface along the profile must lie within the profile tolerance zone and within a size limiting zone. In this application, the datum references only orient the profile of a line tolerance.

**Fig. 8-25 Specifying Combined Profile and Parallelism Tolerances**

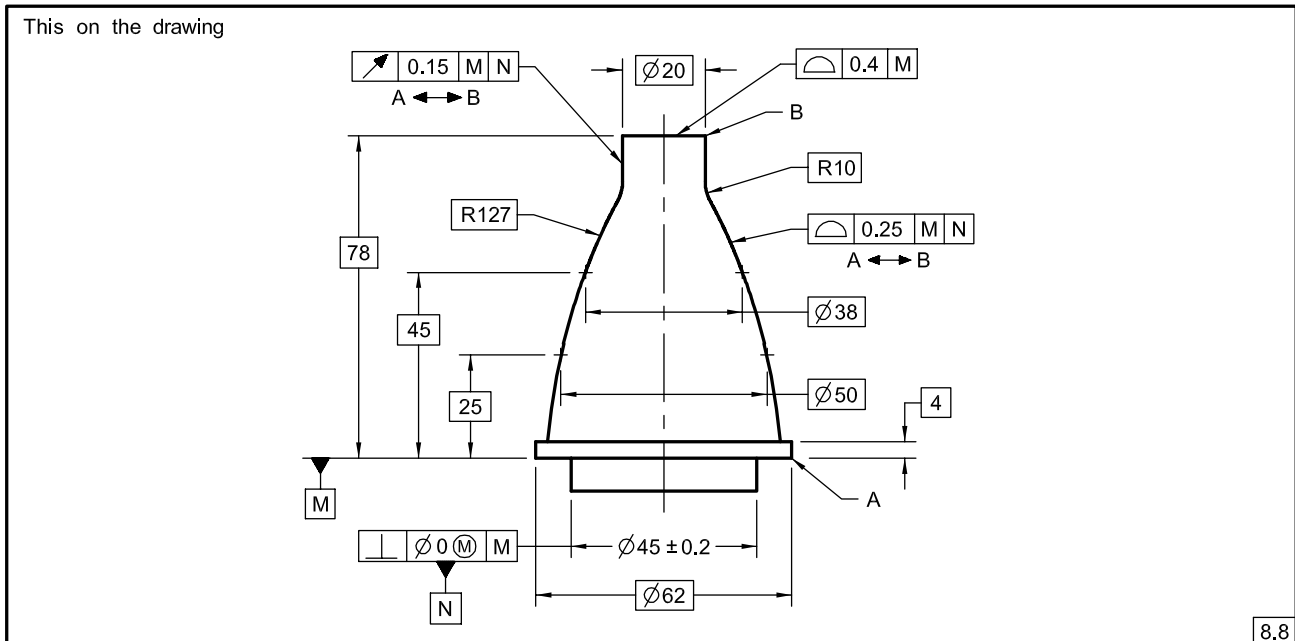


Means this

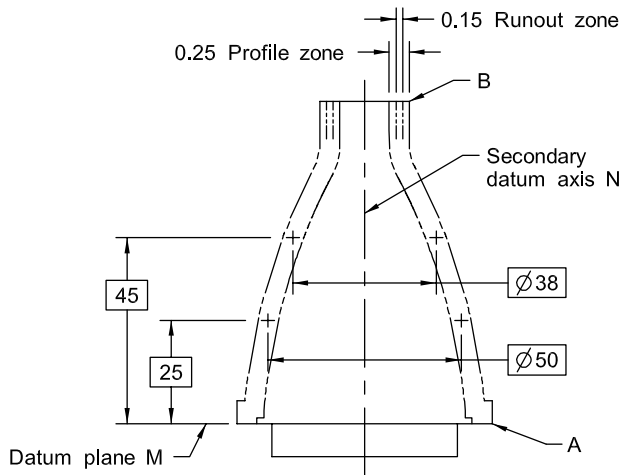


The surface between C and D must lie within the unilateral profile tolerance zone that has one boundary coincident with the true profile and the other boundary inside of the true profile and located with respect to datum planes A and B. Each line element of the considered surface must lie between two lines 0.12 apart which parallel to datum plane A and constrained in rotation to datum plane B.

**Fig. 8-26 Profile of a Surface of Revolution**

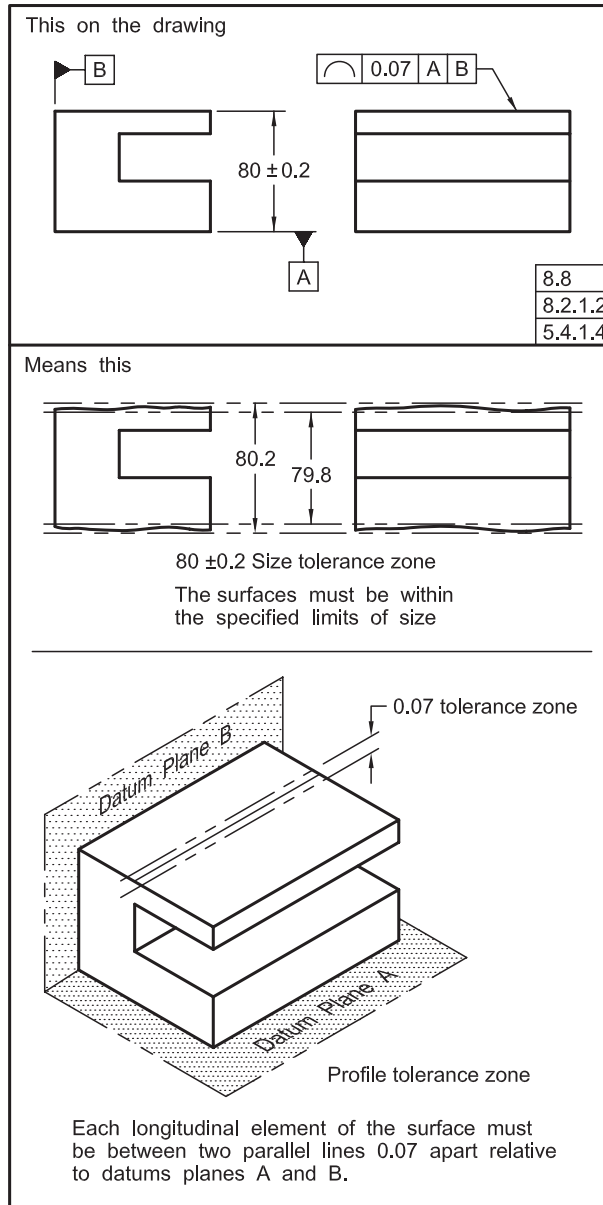


Means this



The surface between A and B must lie between two profile boundaries 0.25 apart, equally disposed about the true profile and positioned with respect to the primary plane M and secondary datum axis N. Additionally, each circular element of the surface must fall within the 0.15 runout tolerance.

**Fig. 8-27 Profile of a Line and Size Control**



## Section 9

# Tolerances of Runout

### 9.1 GENERAL

This Section establishes the principles and methods of dimensioning and tolerancing to control runout of various geometrical shapes.

### 9.2 RUNOUT

Runout is a tolerance used to control the functional relationship of one or more features to a datum axis established from a datum feature specified at RMB.

NOTE: The figures in this Section use measurement techniques to explain the tolerance zones. It is neither the intent nor within the scope of this Standard to define measurement methods.

### 9.3 RUNOUT TOLERANCE

The types of features controlled by runout tolerances include those surfaces constructed around a datum axis and those constructed at right angles to a datum axis. See Fig. 9-1.

#### 9.3.1 Datum Features for Runout Tolerances

The datum axis for a runout tolerance may be established by a cylindrical datum feature of sufficient length, two or more cylindrical datum features having sufficient axial separation, or a cylindrical datum feature and a face at right angles to it. Features used as datum features for establishing axes should be functional, such as mounting features that establish an axis of rotation.

#### 9.3.2 Rotation About an Axis

When the part is rotated about the datum axis, full indicator movement (FIM) for each considered feature must be within its runout tolerance. This may also include the datum features as a part of the runout tolerance control where so designated.

### 9.4 TYPES OF RUNOUT TOLERANCES

There are two types of runout tolerances, circular runout and total runout. The type used is dependent upon design requirements and manufacturing considerations. Circular runout is normally a less complex

requirement than total runout. The following paragraphs describe both types of runout.

#### 9.4.1 Control of Circular Elements

Circular runout provides control of circular elements of a surface. The tolerance is applied independently at each circular measuring position as the part is rotated the full angular extent of the surface about the simulated datum axis. See Fig. 9-2. Where applied to surfaces constructed around a datum axis, circular runout may be used to control the cumulative variations of circularity and coaxiality. Where applied to surfaces constructed at right angles to the datum axis, circular runout controls circular elements of a plane surface (wobble). When verifying circular runout, the indicator is fixed in a position normal to the toleranced surface.

#### 9.4.2 Total Runout for Control of Surfaces

Total runout provides control of all surface elements. The tolerance is applied simultaneously to all circular and profile measuring positions as the part is rotated 360° about the datum axis. See Fig. 9-3. When verifying total runout, the indicator is fixed in orientation normal to and translates along the toleranced surface.

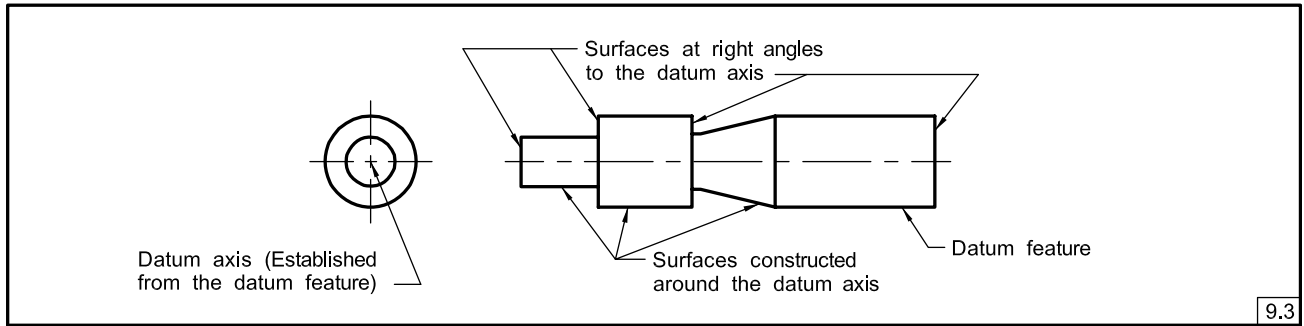
**9.4.2.1 Applied to Surfaces Around an Axis.** Where applied to surfaces, constructed around a datum axis, total runout may be used to control cumulative variations such as circularity, straightness, coaxiality, angularity, taper, and profile of a surface.

**9.4.2.2 Applied to Surfaces Normal to an Axis.** Where applied to surfaces at right angles to a datum axis, total runout controls cumulative variations of perpendicularity (to detect wobble) and flatness (to detect concavity or convexity).

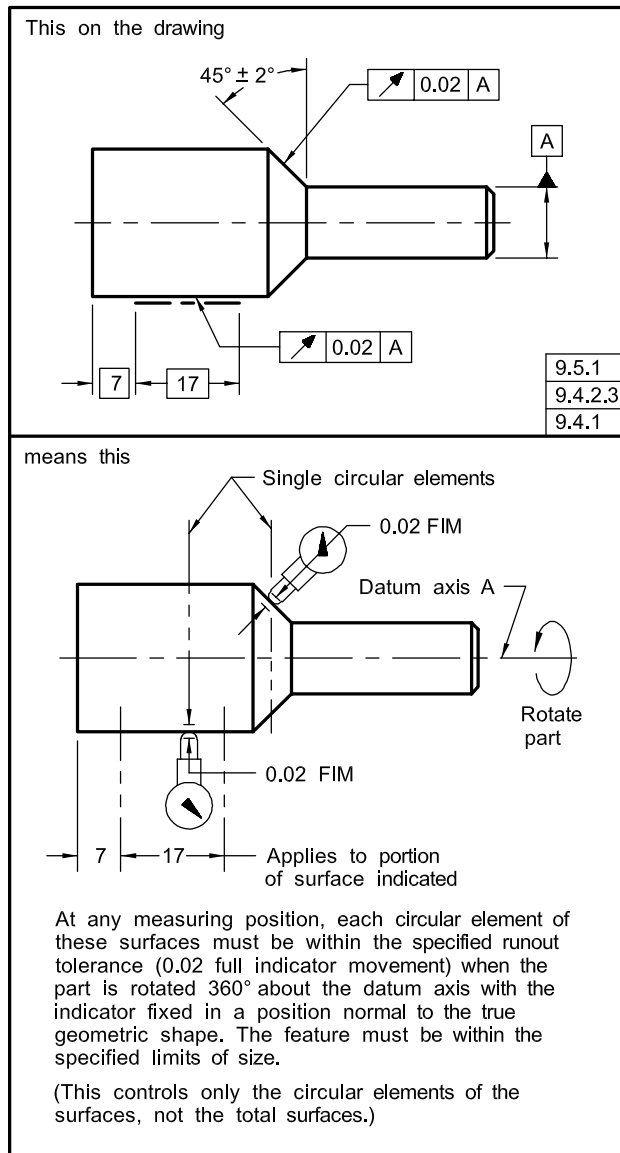
**9.4.2.3 Applied to a Portion of Surface.** Where a runout tolerance applies to a specific portion of a surface, a thick chain line is drawn adjacent to the surface profile on one side of the datum axis for the desired length. Basic dimensions are used to define the extent of the portion so indicated. See Fig. 9-2.



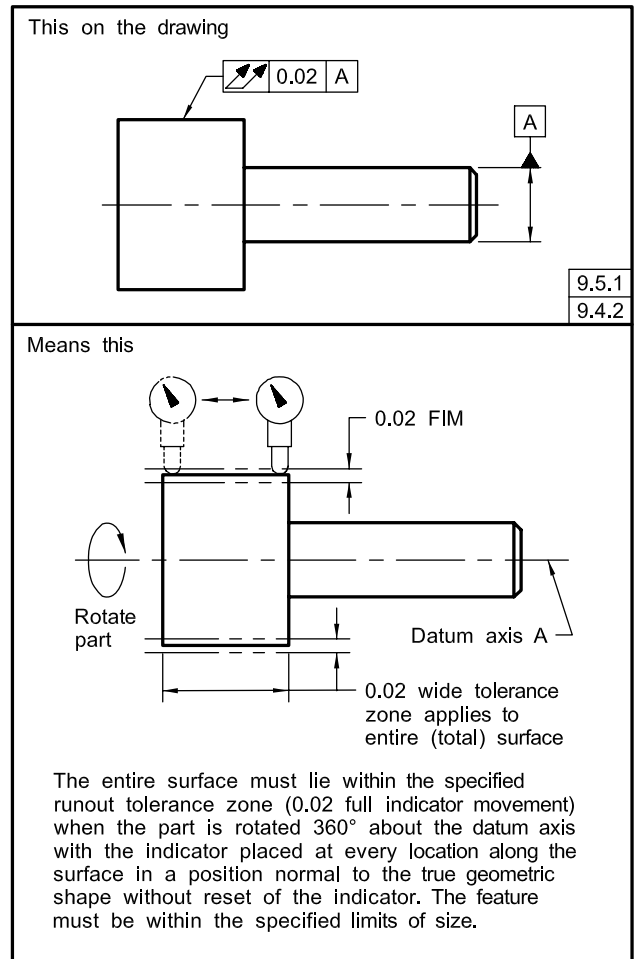
**Fig. 9-1 Features Applicable to Runout Tolerancing**

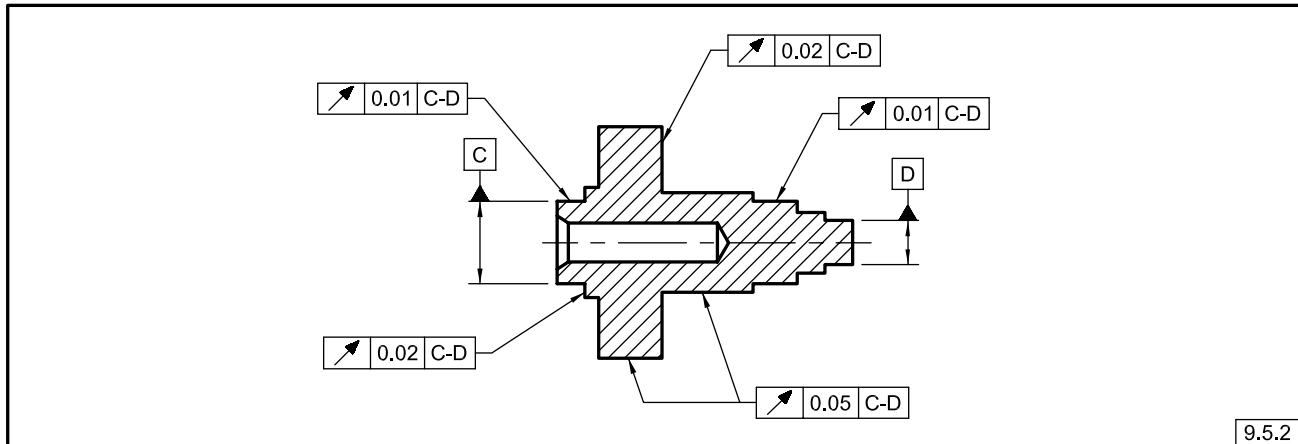


**Fig. 9-2 Specifying Circular Runout Relative to a Datum Diameter**



**Fig. 9-3 Specifying Total Runout Relative to a Datum Diameter**



**Fig. 9-4 Specifying Runout Relative to Two Cylindrical Datum Features**

## 9.5 APPLICATION

The following methods are used to specify a runout tolerance.

### 9.5.1 Control of Diameters to Datum Axis

Where features to be controlled are diameters related to a datum axis, one or more of the diameters are specified as datum features to establish the datum axis, and each related surface is assigned a runout tolerance with respect to this datum axis. Figures 9-2 and 9-3 illustrate the fundamental principle of relating features in a runout tolerance to a datum axis as established from a single cylindrical datum feature of sufficient length. Figure 9-2 incorporates the principle of circular runout tolerancing and illustrates the control of circular elements of a surface. Figure 9-3 incorporates the principle of total runout tolerancing and illustrates the control of an entire surface.

### 9.5.2 Multiple Cylindrical Datum Features

Figure 9-4 illustrates application of runout tolerances where two cylindrical datum features collectively establish a single datum axis to which the features are related.

### 9.5.3 Cylindrical and Planar Datum Features

Where features to be controlled are related to a cylinder and a planar surface at right angles to it, each related surface is assigned a runout tolerance with respect to

the two datums. The datums are specified separately to indicate datum precedence. See Fig. 9-5.

### 9.5.4 Control of Individual Datum Feature Surfaces

It may be necessary to control individual datum feature surface variations with respect to flatness, circularity, parallelism, straightness, or cylindricity. Where such control is required, the appropriate tolerance is specified. See Figs. 9-6 and 9-7 for examples applying cylindricity and flatness to the datum features.

### 9.5.5 Control of Runout to a Datum Feature(s)

Runout tolerance may be applied to a datum feature(s) and related to the datum axis derived from that datum feature(s). See Figs. 9-6 and 9-7.

### 9.5.6 Relationship of Features Based on Datum Sequence

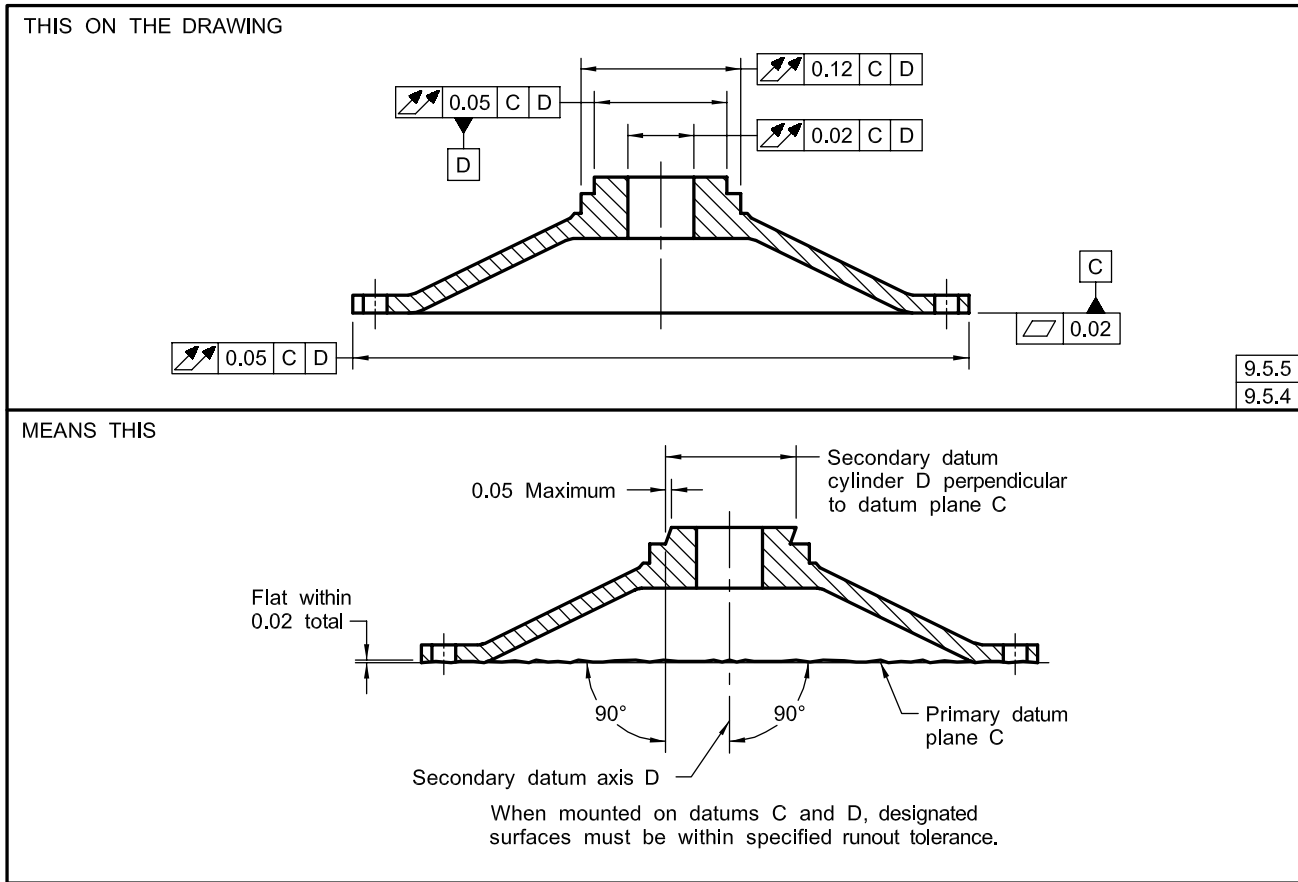
Features having a specific relationship to each other rather than to a common datum axis are indicated by appropriate datum references within the feature control frame. See Fig. 9-6. In this example, the runout tolerance of the hole is related to datum E rather than the axis C-D.

## 9.6 SPECIFICATION

Multiple leaders may be used to direct a feature control frame to two or more surfaces having a common runout tolerance. Surfaces may be specified individually or in groups without affecting the runout tolerance. See Fig. 9-6.



**Fig. 9-7 Specifying Runout Relative to a Surface and Diameter With Form Control Specified**



# NONMANDATORY APPENDIX A

## PRINCIPAL CHANGES AND IMPROVEMENTS

### A.1 GENERAL

The purpose of this Appendix is to provide users a list of the principal changes and improvements in this revision of the Standard as compared to the previous issue. The changes are summarized for each section or appendix in the form of additions, clarifications, extensions of principles, or resolution of differences.

### A.2 STANDARD FORMAT

The format of the Standard has been revised to present the material in the sequence most used when applying geometric dimensioning and tolerancing. Section 1 continues to present the Scope, Definitions, and General Dimensioning. Section 2, as in previous revisions, is General Tolerancing and Related Principles, Section 3 is Symbolology, and Section 4 is Datum Reference Frames. The revisions in sequence begin with Section 5, Tolerances of Form; Section 6, Tolerances of Orientation; Section 7, Tolerances of Location; Section 8, Tolerance of Profile; and Section 9, Tolerances of Runout.

This format was adopted to guide the user of this Standard in first selecting the necessary datums based on the part's function to constrain the workpiece in order to perform the necessary manufacturing steps or to inspect the workpiece. After datums are selected, form tolerances should be considered to control the accuracy of a primary datum, and then orientation controls should be considered to properly relate the secondary datum feature to the primary datum feature. Finally, tertiary datum features are generally related to the primary and secondary datum features using either position or profile tolerancing. In the case of a primary datum feature that is a cylinder, runout tolerancing may be used to control the secondary datum feature in relationship to the datum axis.

Form, orientation, position, profile, and runout are also used to control other features on the workpiece and are not limited to datum features.

Similarly, the text within each section has been reorganized to present the foundational (basic) principles first and then build on the foundations. Additionally, new material has been added where necessary for clarification, or to extend and enhance the principles presented in previous revisions of the Standard.

### A.3 SECTION 1, SCOPE, DEFINITIONS, AND GENERAL DIMENSIONING

#### A.3.1 References Added

Reference to ASME Y14.43 was added in para. 1.1.6, Reference to Gaging.

#### A.3.2 Additional References Added

The following references were added:

- (a) ASME Y14.41-2003, Digital Product Definition Data Practices
- (b) ASME Y14.43-2003, Dimensioning and Tolerancing Principles for Gages and Fixtures
- (c) ASME Y14.38-2007, Abbreviations
- (d) ASME Y14.100-2004, Engineering Drawing Practices

#### A.3.3 Definitions and Terms

Definitions and terms have been enhanced by expansion, addition, clarification, and reorganization.

#### A.3.4 New or Revised Terms and Definitions

- A.3.4.1 boundary, least material (LMB)
- A.3.4.2 boundary, maximum material (MMB)
- A.3.4.3 boundary, regardless of material (RMB)
- A.3.4.4 datum feature
- A.3.4.5 datum target
- A.3.4.6 dimension
- A.3.4.7 dimension reference
- A.3.4.8 envelope, actual mating
- A.3.4.9 unrelated actual mating envelope
- A.3.4.10 related actual mating envelope
- A.3.4.11 feature axis

**A.3.4.12** feature center plane

**A.3.4.13** derived median line

**A.3.4.14** derived median plane

**A.3.4.15** feature of size

(a) regular feature of size

(b) irregular feature of size

**A.3.4.16** plane, tangent

### **A.3.5 Fundamental Rules Revised**

**A.3.5.1** Paragraph 1.4(b) was revised to add “Values may be expressed in an engineering drawing or in a CAD product definition set. (See ASME Y14.41.)”

**A.3.5.2** For para. 1.4(f), the structure of the rule was changed so that the rule is stated first and then examples are given.

### **A.3.6 Fundamental Rules Added**

**A.3.6.1** For para. 1.4(k), a zero basic dimension applies where axes, center planes, or surfaces that are shown congruent on a drawing and geometric controls establish the relationship between the features.

**A.3.6.2** For para. 1.4(p), where a coordinate system is shown on the drawing, it shall be right-handed unless otherwise specified. Each axis shall be labeled, and the positive direction shall be shown.

### **A.3.7 Paragraphs Revised**

**A.3.7.1 Paragraph 1.7.9: Dimensions Not to Scale.** Subparagraph (a) added a requirement for a basic dimension not to scale.

**A.3.7.2 Paragraph 1.8.4: Rounded Ends and Slotted Holes.** Slotted holes were added to this paragraph.

**A.3.7.3 Paragraph 1.8.10: Round Holes.** Clarification added, indicating that when the depth dimension is not clear the dimension should be shown pictorially.

**A.3.7.4 Paragraph 1.8.14: Spotfaces.** Clarification added, indicating that if no depth or remaining material is specified, the spotface is the minimum depth to clean up the surface.

**A.3.7.5 Paragraph 1.8.16.3.** This new paragraph introduces two methods of dimensioning chamfers for surfaces intersecting at angles other than right angles.

## **A.4 SECTION 2, GENERAL TOLERANCING AND RELATED PRINCIPLES**

### **A.4.1 Paragraph 2.1.1**

Paragraph 2.1.1 has been revised to emphasize/encourage the use of use of basic dimensions and geometric tolerancing as the preferred method of controlling the form, orientation, and location of features. The use of direct tolerancing methods, limit dimensioning, and plus minus tolerancing should be used to control the size of features only.

### **A.4.2 Paragraph 2.1.1.4**

Paragraph 2.1.1.4 on implied 90° angles has been expanded to include basically dimensioned angles controlled by geometric tolerancing.

### **A.4.3 Paragraph 2.4**

Paragraph 2.4 on interpretation of limits has been revised to eliminate the discussion on deviation outside the limiting value of a dimension.

### **A.4.4 Paragraph 2.6**

In para. 2.6, a note has been added on the effect of tolerance accumulation when using basic dimensioning.

### **A.4.5 Paragraph 2.7.1**

In para. 2.7.1, Rule #1 has been expanded for clarification.

### **A.4.6 Paragraph 2.7.5**

Limits of size of a continuous feature are defined in para. 2.7.5.

### **A.4.7 Paragraph 2.8.4**

In para. 2.8.4, perfect form at LMC when a tolerance applies at LMC is clarified.

### **A.4.8 Paragraph 2.16**

The placement of the tangent plane symbol within the feature control frame is specified in para. 2.16.

### **A.4.9 Paragraph 2.11.1**

Paragraph 2.11.1 in ASME 14.5M-1994 (Virtual Condition) has been removed. This concept is covered in para. 2.11, Boundary Conditions.

### **A.4.10 Paragraph 2.11.2**

Paragraph 2.11.2 in ASME Y14.5M-1994 (Resultant Condition) has been removed. This concept is covered in para. 2.11, Boundary Conditions.

#### **A.4.11 Paragraph 2.11.3**

Paragraph 2.11.3 in ASME Y14.5M-1994 (Datum Features at Virtual Condition) has been removed. This concept is covered in para. 4.11.9 (Datum Feature Shift/Displacement) and para. 7.3.6 (Datum Feature Modifiers in Positional Tolerances).

### **A.5 SECTION 3, SYMBOLOGY**

#### **A.5.1 Addition of New Symbols**

- A.5.1.1** all over
- A.5.1.2** continuous feature
- A.5.1.3** independency
- A.5.1.4** unequally disposed profile
- A.5.1.5** movable datum target
- A.5.1.6** datum translation

### **A.6 SECTION 4, DATUM REFERENCE FRAMES**

#### **A.6.1 Title**

Section 4 on Datum Reference Frames has been retitled to better reflect the content of the section. It has also been reorganized and several new concepts and some new technology have been incorporated.

#### **A.6.2 Degrees of Freedom**

There is a greater emphasis on the degrees of freedom constrained by the primary, secondary, and tertiary datum features.

#### **A.6.3 Terms**

The following new terms for the boundaries that are derived from datum features have been added.

**A.6.3.1** Maximum Material Boundary (MMB) using the same symbol as MMC.

**A.6.3.2** Least Material Boundary (LMB) using the same symbol as LMC.

**A.6.3.3** Regardless of Material (RMB), which is the implied condition and has no symbol.

#### **A.6.4 Figure 4-3**

New Fig. 4-3 identifies the derived datum and the degrees of freedom constrained by various types of primary datum features at RMB.

#### **A.6.5 Datum Feature Simulator Term**

The term “datum feature simulator” has been defined as theoretically perfect for use in this Standard and has replaced the term “true geometric counterpart.”

#### **A.6.6 Datum Feature Simulator Requirements**

The requirements for datum feature simulators are defined.

#### **A.6.7 Small Assembly Example**

Inclusion of an example of a small assembly and the logic behind the selection of the datum feature for the parts in the assembly is explained.

#### **A.6.8 Calculation of MMB**

Calculation of various MMB depending on the datum features and their order of precedence has been illustrated in Fig. 4-16.

#### **A.6.9 Addition of the Datum Feature Simulator Value in the Feature Control Frame**

The ability to add the value of the datum feature simulator in the feature control frame with either a dimension or the term BASIC or BSC for clarification has been explained.

#### **A.6.10 Datum Feature Shift**

The new term “Datum Feature Shift” is explained.

#### **A.6.11 Secondary and Tertiary Datum Features**

New illustrations of secondary and tertiary datum features at LMB and their effect.

#### **A.6.12 Role of a Secondary or Tertiary Datum**

The role of a secondary or tertiary datum relative to a higher precedence datum axis has been clarified and expanded.

#### **A.6.13 Translation Modifier Symbol**

Introduced a new symbol to indicate that a datum feature simulator translates called a translation modifier.

#### **A.6.14 Symbol for Datum Feature Simulator**

A new symbol for the datum reference frame labeled with the X, Y, Z translational degrees of freedom has been added.

### A.6.15 Part With a Contoured Datum Feature

Illustration of a part with a contoured datum feature has been added.

### A.6.16 Part Contours

Illustrations of several part contours and the effect of datum feature modifiers on these configurations have been added.

### A.6.17 Restrained Parts

New text on restrained parts and the application of datum features to these types of features has been added.

### A.6.18 Customized Datum Reference Frame Construction

A new concept on customized datum reference frame construction and the applicable requirements has been added.

### A.6.19 Movable Datum Target Symbol

A new movable datum target symbol adopted from ASME Y14.8 and ASME Y14.41 has been added.

## A.7 SECTION 5, TOLERANCES OF FORM

### A.7.1 Location of Form Tolerances Section

Form tolerances were formerly in Section 6 with profile, orientation, and runout. To better guide the user of the Standard in the application of geometric dimensioning and tolerancing, form tolerances now are in a separate section.

### A.7.2 Straightness of a Center Plane

Straightness of a center plane has been revised to flatness of a center plane to better reflect that it is a three-dimension control, even though it is the same principle as in the previous edition of the Standard.

## A.8 SECTION 6, TOLERANCES OF ORIENTATION

### A.8.1 Location of Orientation Tolerances Section

Orientation tolerances were formerly in Section 6 with form, profile, and runout. To better guide the user of the Standard in the application of geometric dimensioning and tolerancing, orientation tolerances now are in a separate section.

### A.8.2 Definitions

The definitions of the three orientation tolerances in ASME Y14.5M-1994 were basically the same, the only difference being the inclusion of the particular orientation tolerance. The definitions for angularity, perpendicularity, and parallelism are all in one paragraph, and the text applies to all of the orientation tolerances.

### A.8.3 Angularity Symbol

The use of the angularity symbol meaning orientation is introduced as an alternative practice to using perpendicularity and parallelism.

## A.9 SECTION 7, TOLERANCES OF LOCATION

### A.9.1 Location of Tolerances of Position Section

Tolerances of position were formerly in Section 5. To better guide the user of the Standard in the application of geometric dimensioning and tolerancing, tolerances of position have been moved to the new Section 7.

### A.9.2 Reformatting

Tolerances of position have been reformatted so that the material flows from the basic to more complex principles.

### A.9.3 Definitions

Paragraph 7.2 defines positional tolerances to include their relationship to other features and relative to datums.

### A.9.4 Paragraph 7.2.1.1

Paragraph 7.2.1.1 added basic dimensions defined by CAD data.

### A.9.5 Paragraph 7.3.3.1

Previously a note had indicated that the surface interpretation takes precedence over the axis interpretation of positional tolerance. This was made part of para. 7.3.3.1.

### A.9.6 Paragraph 7.3.5.3

Zero positional tolerance at LMC has been added.

### A.9.7 Effects of Datum References in Positional Tolerances

Effects of datum references in positional tolerances are explained in degrees of freedom.

### A.9.8 Paragraph 7.3.6.2.2

Effects on position tolerances caused by datum feature departure from MMB have been explained.

### A.9.9 Paragraph 7.4.8

Positional tolerances on repetitive patterns of features have been explained.

### A.9.10 Sequential Figures for Composite Positional Tolerances

Sequential figures for composite positional tolerances have been simplified so that each figure contains only the information to build on the previously shown figure. This reduced the amount of information that was



repeated and makes finding the relevant information much easier.

#### **A.9.11 Paragraph 7.5.1.7**

Projected tolerance zones for composite tolerances are shown and explained.

#### **A.9.12 Paragraph 7.5.1.8**

Addition of multiple segments to a composite tolerance feature control frame are illustrated and explained.

#### **A.9.13 Paragraph 7.6.2.3**

Position tolerance is shown without a datum reference to control coaxial features.

#### **A.9.14 Paragraph 7.6.5**

Profile tolerancing has been added as a method to control coaxiality.

### **A.10 SECTION 8, TOLERANCES OF PROFILE**

#### **A.10.1 Location of Tolerances of Profile Section**

Profile tolerances were formerly in Section 6 with form, orientation, and runout. To better guide the user of the Standard in the application of geometric dimensioning and tolerancing, profile tolerances now are in a separate section.

#### **A.10.2 Unequally Disposed Profile Symbol**

A new symbolic method of indicating that a profile tolerance is either unilateral or unequally disposed bilateral using a new unequally disposed profile symbol has been added.

#### **A.10.3 All-Over Application of Profile**

Two ways may now be used for the all-over application of profile. A new symbol has been created, placed at the intersection of the horizontal and radial portions of the leader line from the feature control frame, or the term "ALL OVER" may be used beneath the feature control frame.

#### **A.10.4 Application of a Non-Uniform Tolerance Zone**

An application of a non-uniform tolerance zone has been illustrated. The term "NON-UNIFORM" replaces the tolerance value in the feature control frame and the two extremes of the tolerance zone are dimensioned.

#### **A.10.5 Abrupt Transitions**

Abrupt transitions when different profile tolerances are specified on adjoining segments of a feature has

been addressed with the use of a non-uniform tolerance application.

#### **A.10.6 X Symbol**

The X symbol (for example, 2X) has replaced the note designation (for example, 2 SURFACES) for a number of surfaces.

#### **A.10.7 Control of Two or More Offset Surfaces**

An example has been added for control of two or more offset surfaces to each other similar to co-planar surfaces.

#### **A.10.8 Boundary of an Irregular Feature of Size**

The term "BOUNDARY" beneath the feature control frame is now optional in an application where it is necessary to control the boundary of an irregular feature of size.

#### **A.10.9 Composite Profile Tolerancing**

Composite profile tolerancing has been expanded to include multiple features in a pattern.

#### **A.10.10 Profile Locating Features**

Profile, with a datum reference, has replaced plus/minus (+/-) for location of features to each other or other features on a part.

### **A.11 SECTION 9, TOLERANCES OF RUNOUT**

Runout tolerances were formerly in Section 6 with form, profile, and orientation. To better guide the user of the Standard in the application of geometric dimensioning and tolerancing, runout tolerances now are in a separate section.

### **A.12 NONMANDATORY APPENDIX A**

Nonmandatory Appendix A has been completely revised to reflect the revisions in this revision of the Standard.

### **A.13 NONMANDATORY APPENDIX B**

#### **A.13.1 Metric Values**

Nonmandatory Appendix B has been revised to reflect actual metric values for the illustrated fastener sizes and has used the same size fastener throughout the appendix for uniformity.

#### **A.13.2 B7 Limits and Fits**

B7, Limits and Fits, has been revised to better reflect actual practice.

**A.14 NONMANDATORY APPENDIX C****A.14.1 New Symbols**

The new symbols listed below have been introduced.

- A.14.1.1** movable datum target
- A.14.1.2** all over
- A.14.1.3** unequally disposed profile
- A.14.1.4** translation modifier
- A.14.1.5** independency
- A.14.1.6** continuous feature

**A.14.2 Comparison of Symbols**

The symbols listed below have been added to the Comparison of Symbols charts.

- A.14.2.1** all over
- A.14.2.2** at maximum material boundary
- A.14.2.3** at least material boundary
- A.14.2.4** continuous feature
- A.14.2.5** unequally disposed profile
- A.14.2.6** translation modifier
- A.14.2.7** spotface

- A.14.2.8** movable datum target

**A.15 NONMANDATORY APPENDIX D**

Information on significant former practices once featured in the 1994 issue of this Standard is provided.

**A.16 NONMANDATORY APPENDIX E****A.16.1**

The flow of material has been revised so that the order of the figures reflects the order that various subjects are addressed in this Standard.

- A.16.1.1** Figure E-1: Design Requirements
- A.16.1.2** Figure E-2: Datum Selections
- A.16.1.3** Figure E-3: Form
- A.16.1.4** Figure E-4: Orientation
- A.16.1.5** Figure E-5: Location
- A.16.1.6** Figure E-6: Profile
- A.16.1.7** Figure E-7: Runout

**A.16.2**

Datum selection has been revised to reflect the possibility of applying material modifiers (MMB and LMB) to plane surfaces.

**A.16.3**

Form has been revised to include the new concept of flatness rather than straightness of a center plane.

# NONMANDATORY APPENDIX B

## FORMULAS FOR POSITIONAL TOLERANCING

### B.1 GENERAL

The purpose of this Appendix is to present formulas for determining the required positional tolerances or the required sizes of mating features to ensure that parts will assemble. The formulas are valid for all types of features or patterns of features and will give a “no interference, no clearance” fit when features are at maximum material condition with their locations in the extreme of positional tolerance. Consideration must be given for additional geometric conditions that could affect functions not accounted for in the following formulas.

### B.2 FORMULA SYMBOLS

#### B.2.1 Use of Symbols

Formulas given herein use the five symbols listed below.

**B.2.1.1**  $D$  = minimum depth of thread or minimum thickness of part with restrained or fixed fastener

**B.2.1.2**  $F$  = maximum diameter of fastener (MMC limit)

**B.2.1.3**  $H$  = minimum diameter of clearance hole (MMC limit)

**B.2.1.4**  $P$  = maximum thickness of part with clearance hole, or maximum projection of fastener, such as a stud

**B.2.1.5**  $T$  = positional tolerance diameter

#### B.2.2 Subscripts

Subscripts are used where more than one size feature or tolerance is involved.

### B.3 FLOATING FASTENER CASE

Where two or more parts are assembled with fasteners, such as bolts and nuts, and all parts have clearance holes for the bolts, it is termed the “floating fastener case.” See Fig. B-1. Where the fasteners are of the same diameter, and it is desired to use the same clearance hole diameters and the same positional tolerances for the parts to be assembled, the following formula applies:

$$H = F + T$$

or

$$T = H - F$$

**EXAMPLE:** Given that the fasteners in Fig. B-1 are 6-diameter maximum and the clearance holes are 6.44-diameter minimum, find the required positional tolerance:

$$\begin{aligned} T &= 6.44 - 6 \\ &= 0.44 \text{ diameter for each part} \end{aligned}$$

Any number of parts with different hole sizes and positional tolerances may be mated, provided the formula  $H = F + T$  or  $T = H - F$  is applied to each part individually.

### B.4 FIXED FASTENER CASE WHEN PROJECTED TOLERANCE ZONE IS USED

Where one of the parts to be assembled has restrained fasteners, such as screws in tapped holes or studs, it is termed the “fixed fastener case.” See Fig. B-2. Where the fasteners are of the same diameter and it is desired to use the same positional tolerance in each of the parts to be assembled, the following formula applies:

$$H = F + 2T$$

or

$$T = \frac{H - F}{2}$$

Note that the allowable positional tolerance for each part is one-half that for the comparable floating fastener case.

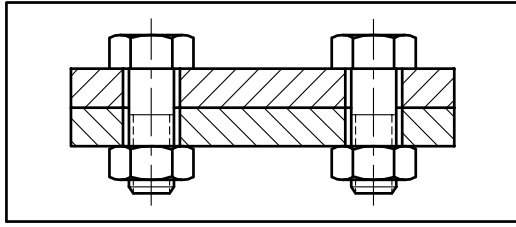
**EXAMPLE:** Given that the fasteners in Fig. B-2 have a maximum diameter of 6 and the clearance holes have a minimum diameter of 6.44, find the required positional tolerance:

$$\begin{aligned} T &= \frac{6.44 - 6}{2} \\ &= 0.22 \text{ diameter for each part} \end{aligned}$$

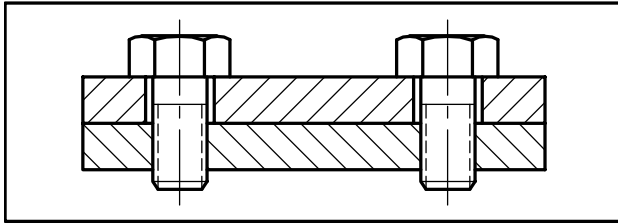
Where it is desired that the part with tapped holes have a larger positional tolerance than the part with clearance holes, the total positional tolerance of both holes ( $2T$ ) can be separated into  $T_1$  and  $T_2$  in any appropriate manner such that

$$2T = T_1 + T_2$$

**Fig. B-1 Floating Fasteners**



**Fig. B-2 Fixed Fasteners**



**EXAMPLE:**  $T_1$  could be 0.18, then  $T_2$  would be 0.26.

The general formula for the fixed fastener case where two mating parts have different positional tolerances is

$$H = F + T_1 + T_2$$

The preceding formulas do not provide sufficient clearance for the fixed fastener case when threaded holes or holes for tight fitting members, such as dowels, are out of square. To provide for this condition, the projected tolerance zone method of positional tolerancing should be applied to threaded holes or tight-fitting holes. See Section 7.

**B.5 PROVISION FOR TILTING OF THE AXIS OR CENTER PLANE WHEN PROJECTED TOLERANCE ZONE IS NOT USED**

When the projected tolerance zone system is not used, it is required to select a positional tolerance and clearance hole combination that compensates for the allowable tilting of the axis of center plane of the part that contains the fixed fastener. The following formula may be used:

$$H = F + T_1 + T_2 \left( 1 + \frac{2P}{D} \right)$$

where

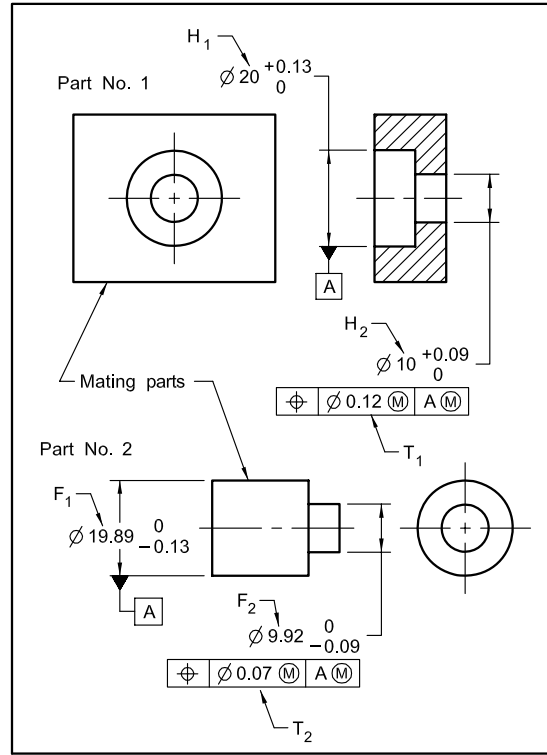
$T_1$  = positional tolerance diameter of clearance hole

$T_2$  = positional tolerance diameter of tapped or tight-fitting holes

$D$  = the minimum depth of engagement of threaded or tight fitting member

$P$  = maximum projection of fastener

**Fig. B-3 Coaxial Features**



**EXAMPLE:** Given that the fasteners in Fig. B-2 have the maximum diameter of 6 ( $F$ ), the positional tolerance of the clearance hole is 0.2 ( $T_1$ ), the positional tolerance of the tapped hole is 0.4 ( $T_2$ ), the maximum thickness of the plate with the clearance hole is 12 ( $P$ ), and the minimum thickness of the plate with the tapped hole is 8 ( $D$ ), find the required clearance hole size ( $H$ ).

$$\begin{aligned} H &= F + T_1 + T_2 \left( 1 + \frac{2P}{D} \right) \\ &= 6 + 0.2 + 0.4 \left( 1 + \frac{2 \times 12}{8} \right) \\ &= 6 + 0.2 + 0.4 (1 + 3) \\ &= 6 + 0.2 + 0.4 (4) \\ &= 6 + 0.2 + 1.6 \\ &= 7.8 \end{aligned}$$

**B.6 COAXIAL FEATURES**

The formula below applies to mating parts having two coaxial features where one of these features is a datum feature for the other. See Fig. B-3. Where it is desired to divide the available tolerance unequally between the parts, the following formula is useful:

$$H_1 + H_2 = F_1 + F_2 + T_1 + T_2$$

(This formula is valid only for simple coaxial parts that are of similar length as shown here. Consideration must be given for other geometric conditions [i.e. orientation, projected tolerance, etc.] that may be required for function.)

**EXAMPLE:** Given the information shown in Fig. B-3, solve for  $T_1$  and  $T_2$ :

$$\begin{aligned} H_1 + H_2 &= F_1 + F_2 + T_1 + T_2 \\ T_1 + T_2 &= (H_1 + H_2) - (F_1 + F_2) \\ &= (20 + 10) - (19.89 + 9.92) \\ &= 0.19 \text{ total available tolerance} \end{aligned}$$

This total available tolerance may be divided in any desired manner, such as

$$\begin{aligned} T_1 &= 0.12 \\ T_2 &= 0.07 \end{aligned}$$

## B.7 LIMITS AND FITS

Where requirements for the size and fit of mating features are specified by symbols per ANSI B4.2, the formulas for positional tolerancing are also applicable.

The above symbols have been used with ANSI B4.2, Table 2 to obtain the limit values shown in Fig. B-3. Table B2 and B3 of ANSI B4.2 show the following:

(a) For the hole basic size 20,

$$\text{Fundamental Deviation } H_{20} = 0$$

(b) For the hole basic size 10,

$$\text{Fundamental Deviation } H_{10} = 0$$

(c) For the shaft basic size 20,

$$\text{Fundamental Deviation } c_{20} = -0.11$$

(d) For the shaft basic size 10,

$$\text{Fundamental Deviation } c_{10} = -0.08$$

Note that the total available tolerance is

$$\begin{aligned} T_1 + T_2 &= (H_{20} - c_{20}) + (H_{10} - c_{10}) \\ &= (0 - 0.11) + (0 - 0.08) \\ &= 0.19 \end{aligned}$$

This total available tolerance may be divided in any desired manner, such as

$$\begin{aligned} T_1 &= 0.12 \\ T_2 &= 0.07 \end{aligned}$$

# NONMANDATORY APPENDIX C FORM, PROPORTION, AND COMPARISON OF SYMBOLS

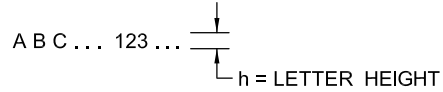
## C.1 GENERAL

The purpose of this Appendix is to present the recommended form and proportion for symbols used in dimensioning and tolerancing applications and to compare ASME and ISO symbols.

## C.2 FORM AND PROPORTION

Figures C-1 through C-5 illustrate the preferred form and proportion of symbols established by this Standard for use on engineering drawings. The symbols are grouped to illustrate similarities in the elements of their construction. In all figures, symbol proportions are given in a factor of  $h$ , where  $h$  is the letter height selected for

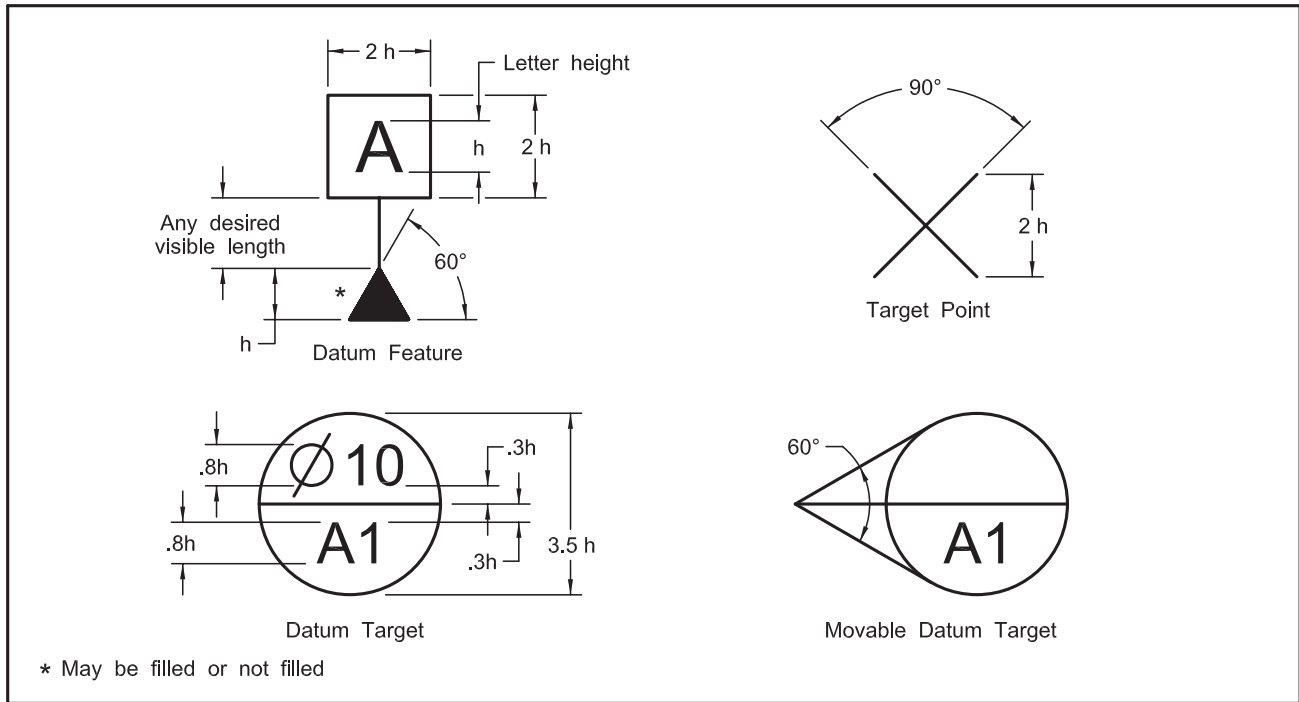
use within the enclosed symbols. See ASME Y14.2 for line weights, letter heights, and arrow proportions.



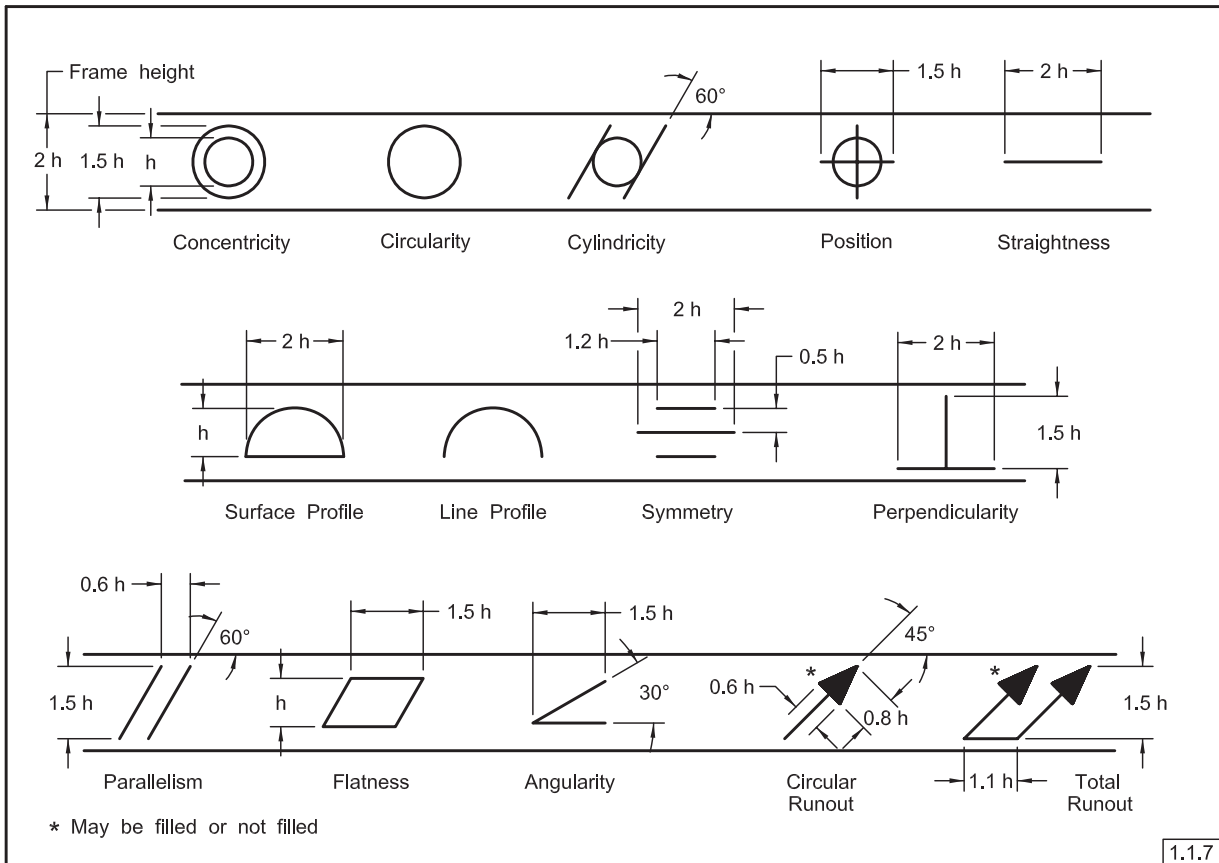
## C.3 COMPARISON

Figures C-6 and C-7 provide a comparison of the symbols adopted by this Standard with those contained in the international standards such as ISO 1101, 129, and 3040. In some instances this Standard and the ISO standards use the same symbol, but with a different name or different meaning.

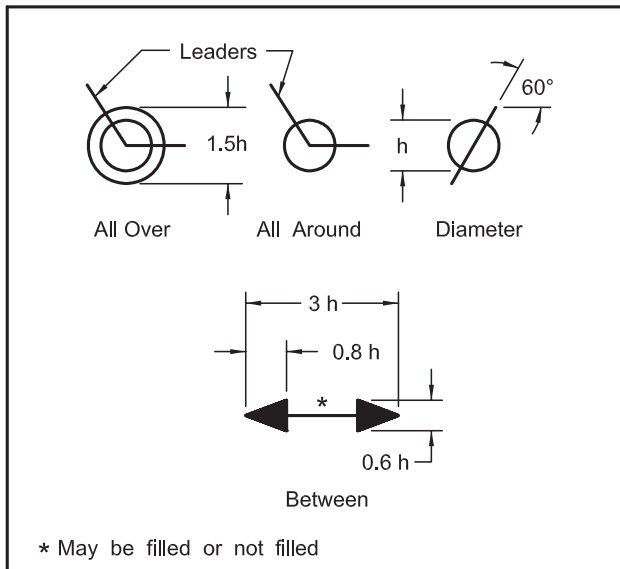
**Fig. C-1 Form and Proportion of Datum Symbols**



**Fig. C-2 Form and Proportion of Geometric Characteristic Symbols**



**Fig. C-3 Form and Proportion of Geometric Dimensioning Symbols**



**Fig. C-4 Form and Proportion of Modifying Symbols**

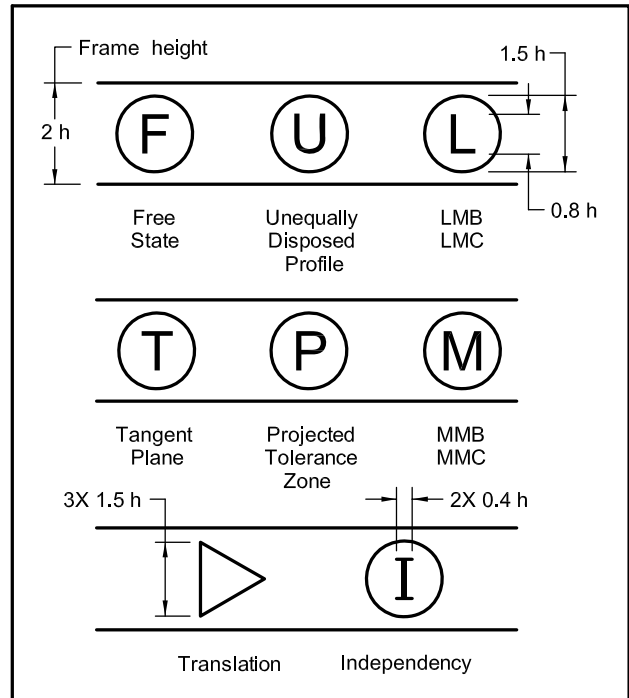


Fig. C-5 Form and Proportion of Dimensioning Symbols and Letters

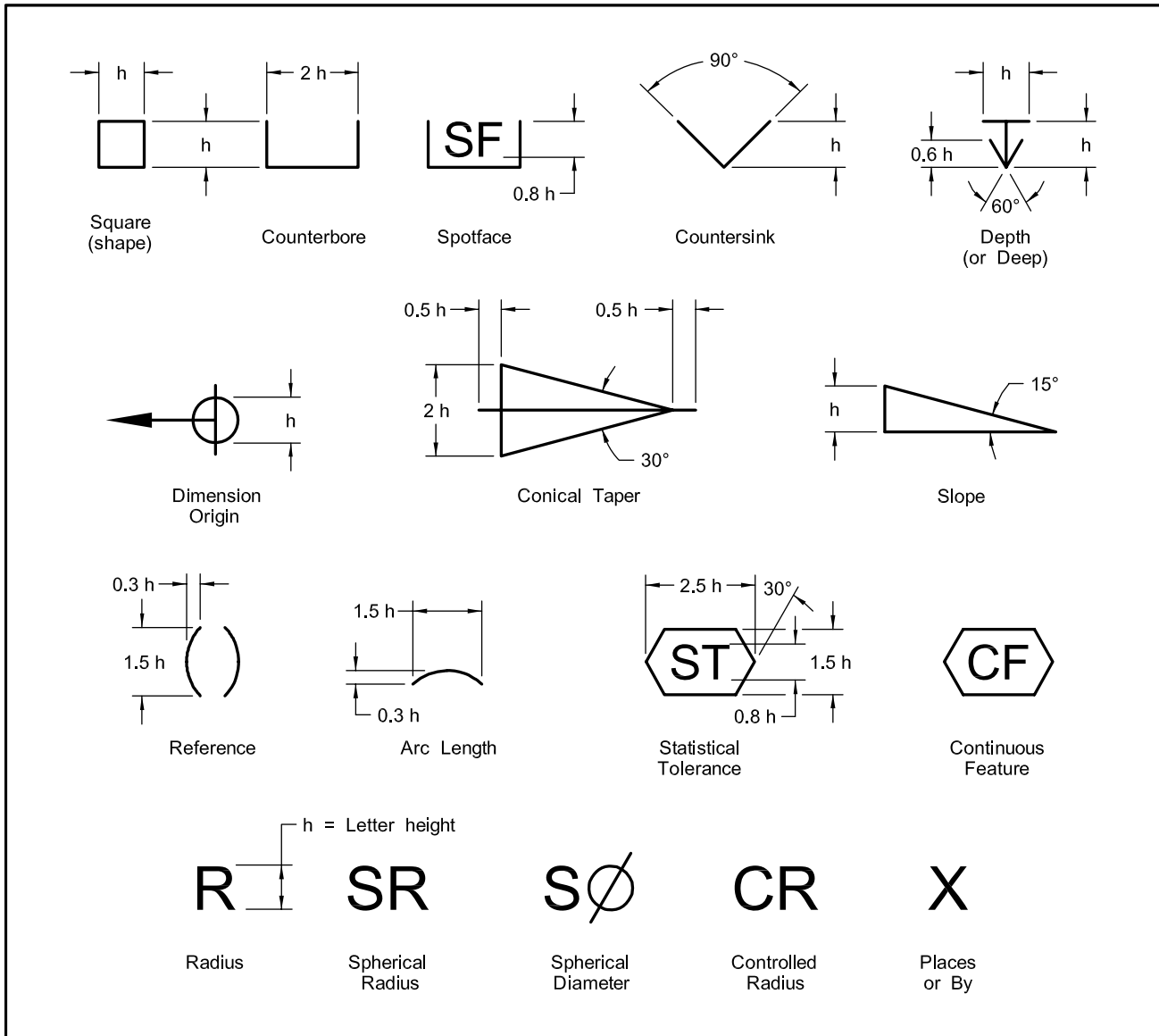




Fig. C-6 Comparison of Symbols

SYMBOL FOR:	ASME Y14.5	ISO
STRAIGHTNESS	—	—
FLATNESS		
CIRCULARITY		
CYLINDRICITY	//	//
PROFILE OF A LINE		
PROFILE OF A SURFACE		
ALL AROUND		
ALL OVER		(proposed)
ANGULARITY	<	<
PERPENDICULARITY		
PARALLELISM	//	//
POSITION		
CONCENTRICITY (Concentricity and Coaxiality in ISO)		
SYMMETRY		
CIRCULAR RUNOUT		
TOTAL RUNOUT		
AT MAXIMUM MATERIAL CONDITION		
AT MAXIMUM MATERIAL BOUNDARY		NONE
AT LEAST MATERIAL CONDITION		
AT LEAST MATERIAL BOUNDARY		NONE
PROJECTED TOLERANCE ZONE		
TANGENT PLANE		NONE
FREE STATE		
UNEQUALLY DISPOSED PROFILE		UZ (proposed)
TRANSLATION		NONE
DIAMETER	$\varnothing$	$\varnothing$
BASIC DIMENSION (Theoretically Exact Dimension in ISO)		
REFERENCE DIMENSION (Auxiliary Dimension in ISO)	(50)	(50)
DATUM FEATURE		or

\* May be filled or not filled

Fig. C-7 Comparison of Other Symbols

SYMBOL FOR:	ASME Y14.5	ISO
DIMENSION ORIGIN		
FEATURE CONTROL FRAME		
CONICAL TAPER		
SLOPE		
COUNTERBORE		NONE
SPOTFACE		NONE
COUNTERSINK		NONE
DEPTH/DEEP		NONE
SQUARE		
DIMENSION NOT TO SCALE		
NUMBER OF PLACES	8X	8X
ARC LENGTH		
RADIUS	R	R
SPHERICAL RADIUS	SR	SR
SPHERICAL DIAMETER	S $\varnothing$	S $\varnothing$
CONTROLLED RADIUS	CR	NONE
BETWEEN	*	
STATISTICAL TOLERANCE		NONE
CONTINUOUS FEATURE		NONE
DATUM TARGET		
MOVABLE DATUM TARGET		
TARGET POINT		
* May be filled or not filled		

## NONMANDATORY APPENDIX D FORMER PRACTICES

### D.1 GENERAL

The purpose of this Appendix is to identify and illustrate former symbols, terms, and methods of dimensioning featured in ASME Y14.5M-1994. For information on changes and improvements, see Nonmandatory Appendix A and the Foreword. The following information is provided to assist the interpretation of existing drawings on which former practices may appear.

### D.2 SPECIFICATION OF RFS FOR POSITION TOLERANCES

In the previous issue, the RFS symbol was no longer required to indicate “regardless of feature size” for a tolerance of position. An alternate Rule #2(b) allowed the

option of continuing that practice. In this revision of the Standard, Rule #2(b) has been eliminated.

### D.3 SPECIFICATION OF STRAIGHTNESS TO CONTROL THE FLATNESS OF A DERIVED MEDIAN PLANE

The practice of using straightness to control the flatness of a derived median plane has been discontinued.

### D.4 MMC, LMC, AND RFS FOR DATUM FEATURES

The terms “MMC,” “LMC,” and “RFS” no longer are used in reference to datum features. The current terms are “MMB,” “LMB,” and “RMB.”

# NONMANDATORY APPENDIX E

## DECISION DIAGRAMS FOR GEOMETRIC CONTROL

### E.1 PURPOSE

The purpose of this Appendix is to assist the user in selecting the correct geometric characteristic for a particular application. Decision diagrams that are based on design requirements and the application of datums, geometric tolerances, and modifiers have been developed. The diagrams encourage the user to think in terms of design intent and functional requirements, and assist in the development of the contents of feature control frames.

### E.2 FUNCTIONAL REQUIREMENTS

When documenting design intent, the user must consider both the stabilization of the part and the functional requirements of the individual features. See Fig. E-1. In dealing with Individual Features, both Form and Profile controls must be considered. If the application deals with Related Features, then Location, Orientation, Runout, and Profile controls must be considered.

#### E.2.1 Type of Application

Once the type of application is determined, the user is directed to more specific diagrams. These diagrams prompt additional user decisions, such as what needs to be controlled (center plane, axis, or surface), functional tolerance to be met, applicable modifiers, and necessary datum relationships.

### E.3 REFERENCE TO STANDARD

A reference is shown in many diagram boxes to the appropriate section within ASME Y14.5-2009 that contains specific information concerning that control.

### E.4 GEOMETRIC CONTROLS

The box titled "Consider Limits of Size" serves as a reminder to examine the size limits before applying additional form controls. See Fig. E-3. As stated in para. 2.7.1, the dimensional limits of a feature of size may also serve to control the allowable variations in form (Rule #1). When this is the case, and the functional requirements of the design are met, no additional form controls are needed.

#### E.4.1 Choosing Form Controls

Assuming that form controls are necessary, the diagrams lead the user through the various applications and suggests a variety of possible choices, as dictated by the design function. See Fig. E-3.

### E.5 CHOOSING OTHER CONTROLS

Other aspects of each feature of a part must be considered for their orientation, location, profile, and runout as they relate to other features. The diagrams shown in Figs. E-4 through E-7 have been developed to guide the user through the appropriate selection processes.

### E.6 USE OF MODIFIERS

Modifiers are an integral part of geometric tolerances, but are only applicable when utilizing features of size. If a modifier is not applicable to the geometric characteristic, modifiers are not included in the decision diagrams. See Figs. E-2 through E-5. In the cases where modifiers are applicable, the diagrams prompt decisions as to which modifiers are appropriate.

### E.7 DATUMS

Like modifiers, datums do not apply to all geometric characteristics. Datums do not apply to form controls. If datums do not apply, they are not addressed in the diagrams. When datums are applicable, the user is referred to Fig. E-2.

#### E.7.1 Datum Modifiers

When a feature of size has been selected as a datum, a material boundary modifier must be considered. See Fig. E-2 and para. 2.8.

#### E.7.2 Multiple Datums

Some applications require only a primary datum, while others may need secondary and tertiary datums. When more than one datum is needed, the diagrams loop back until the datum reference framework is complete. See Fig. E-2.

**Fig. E-1 Design Requirements**

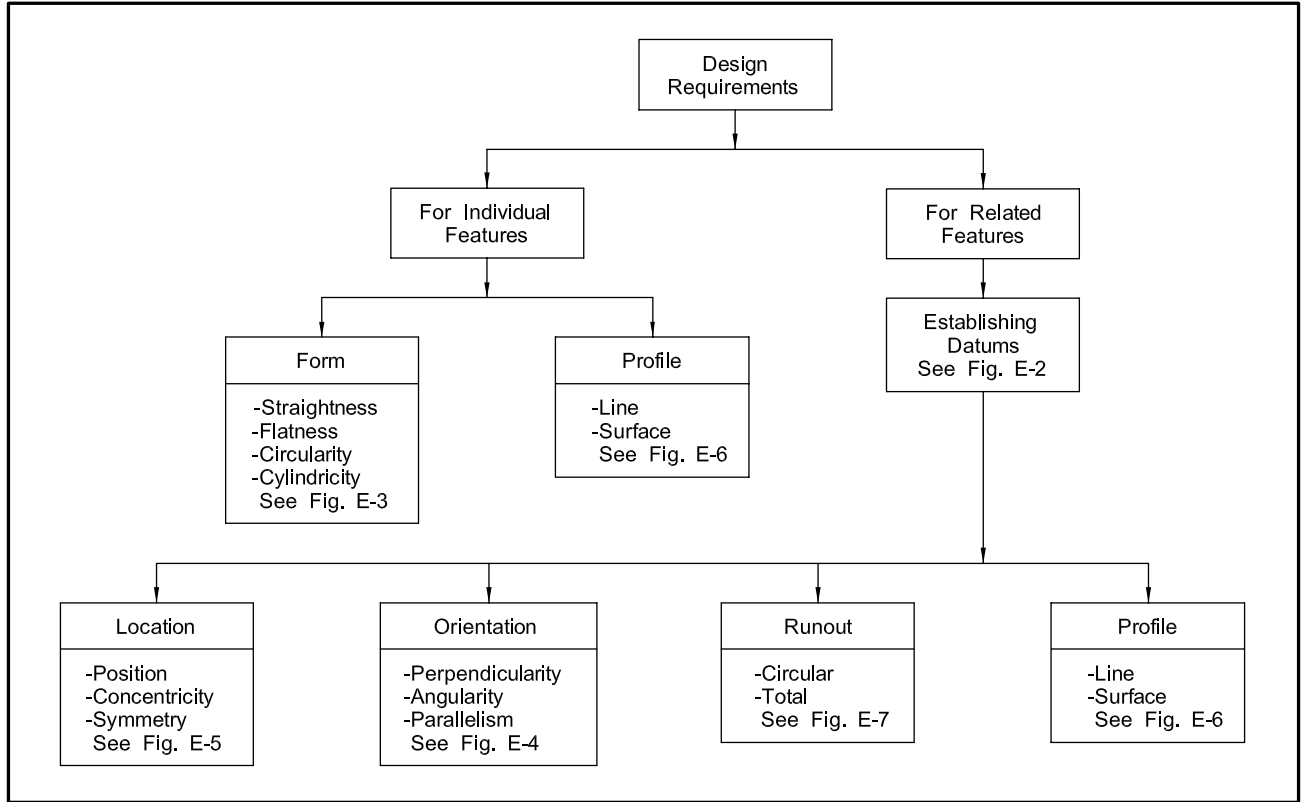


Fig. E-2 Datum Selections

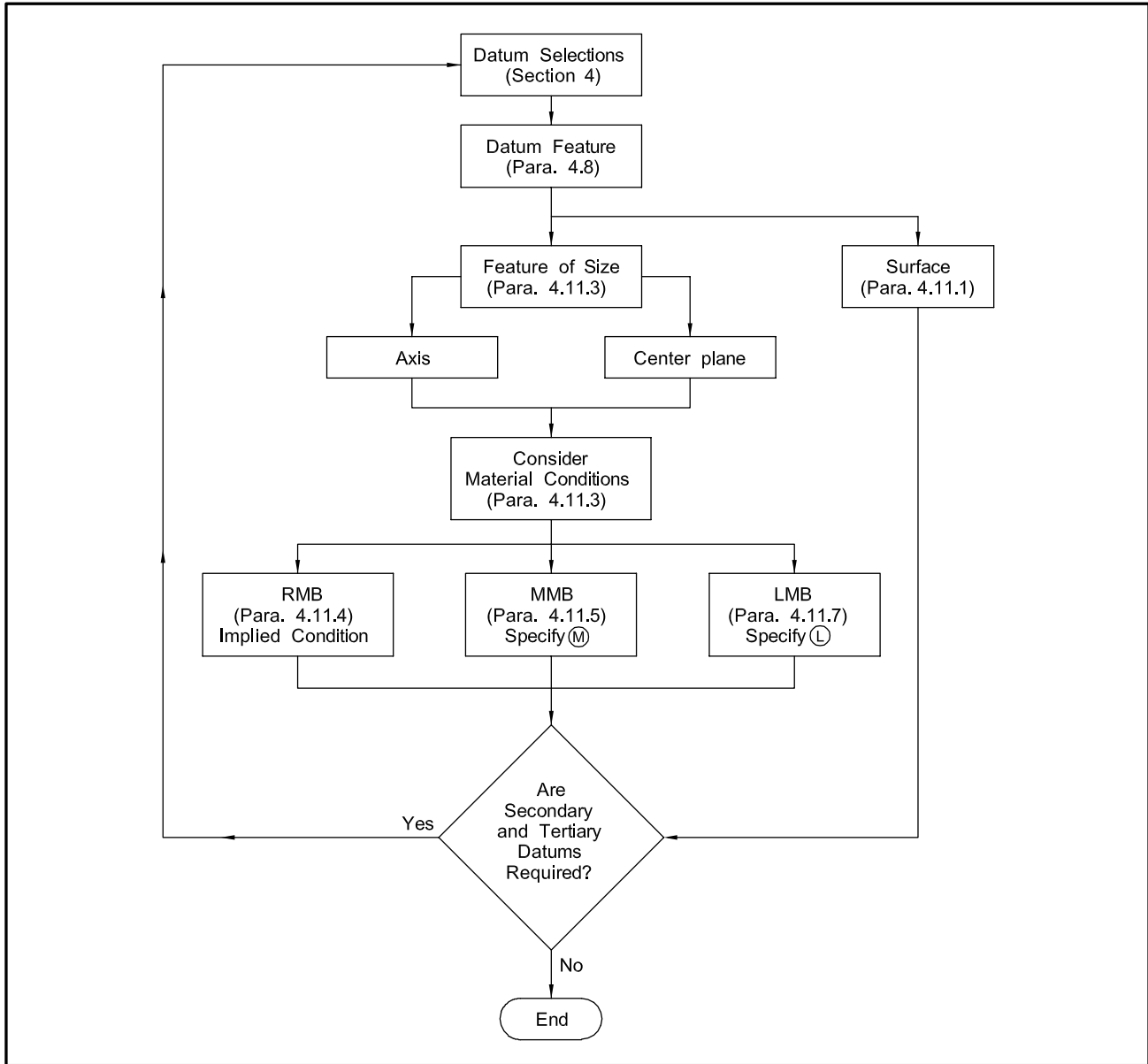


Fig. E-3 Form

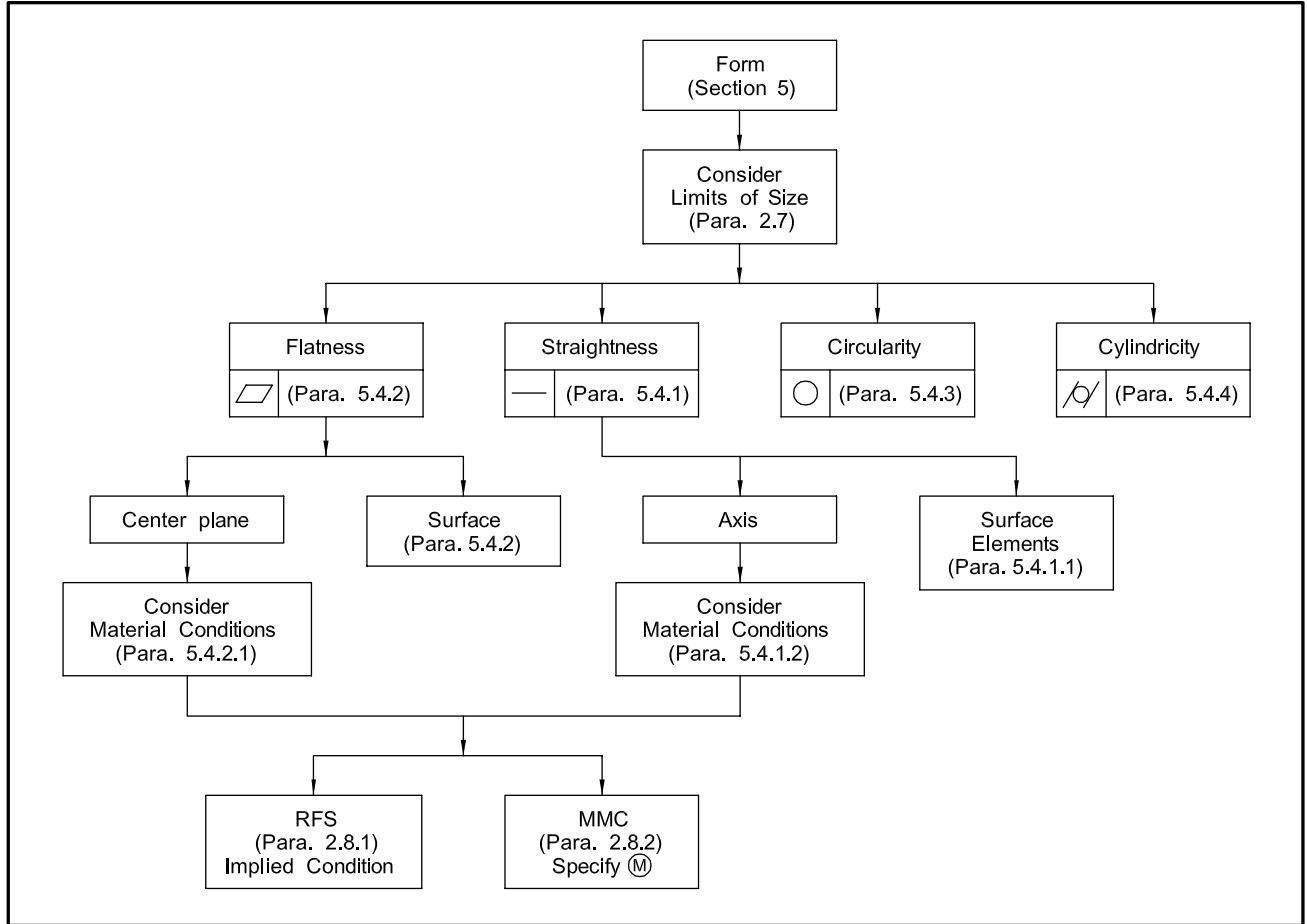


Fig. E-4 Orientation

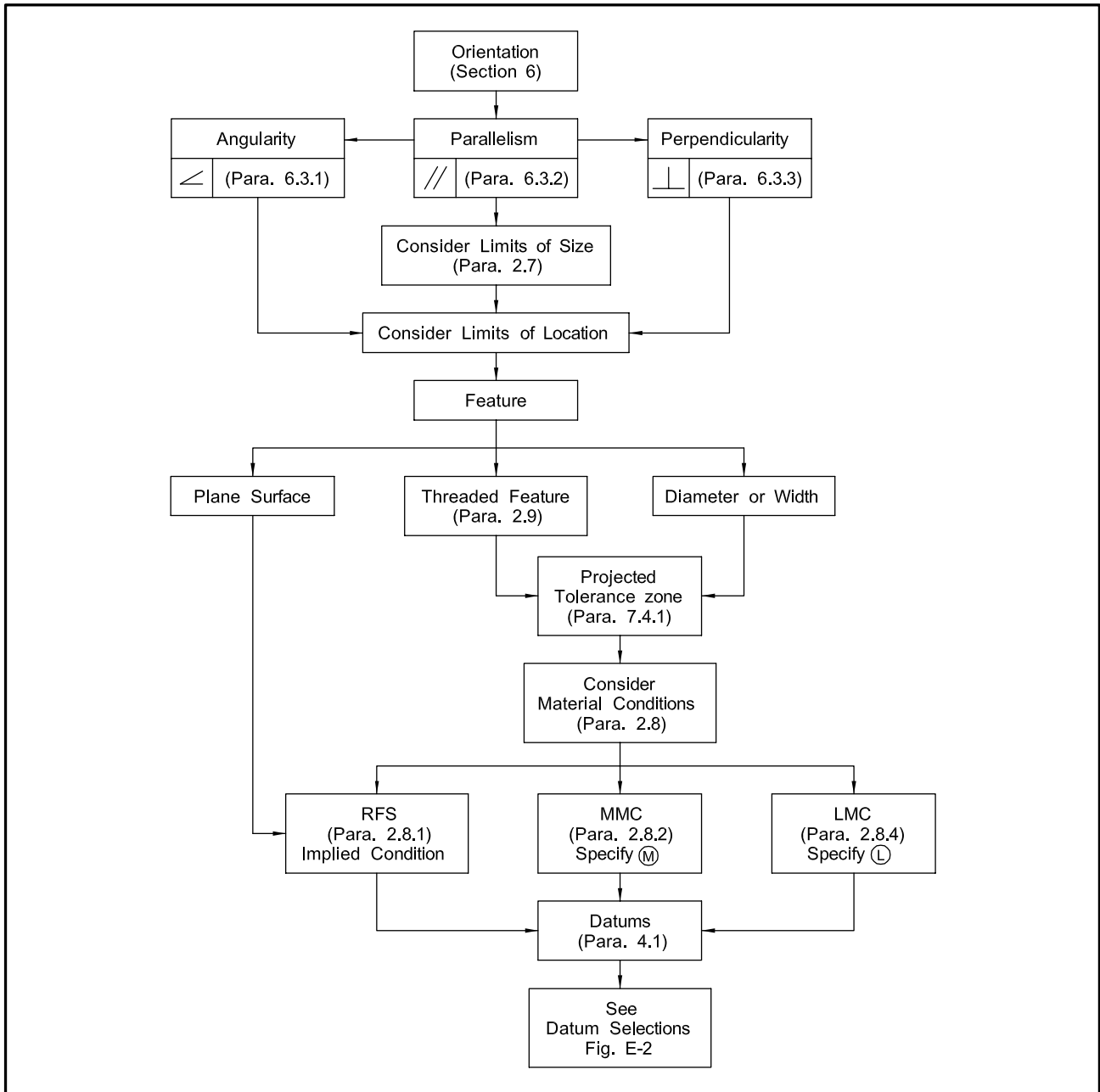




Fig. E-5 Location

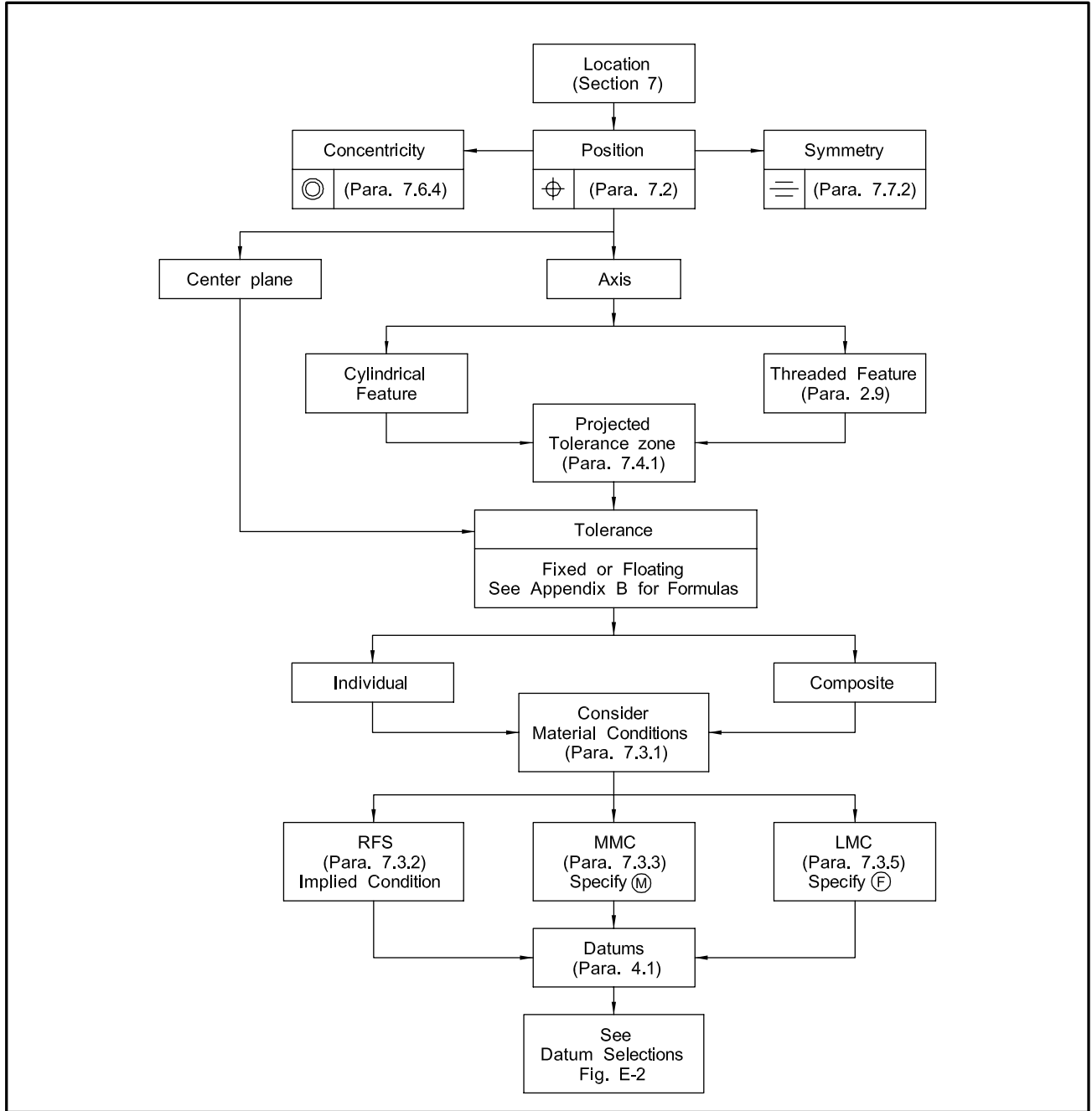


Fig. E-6 Profile

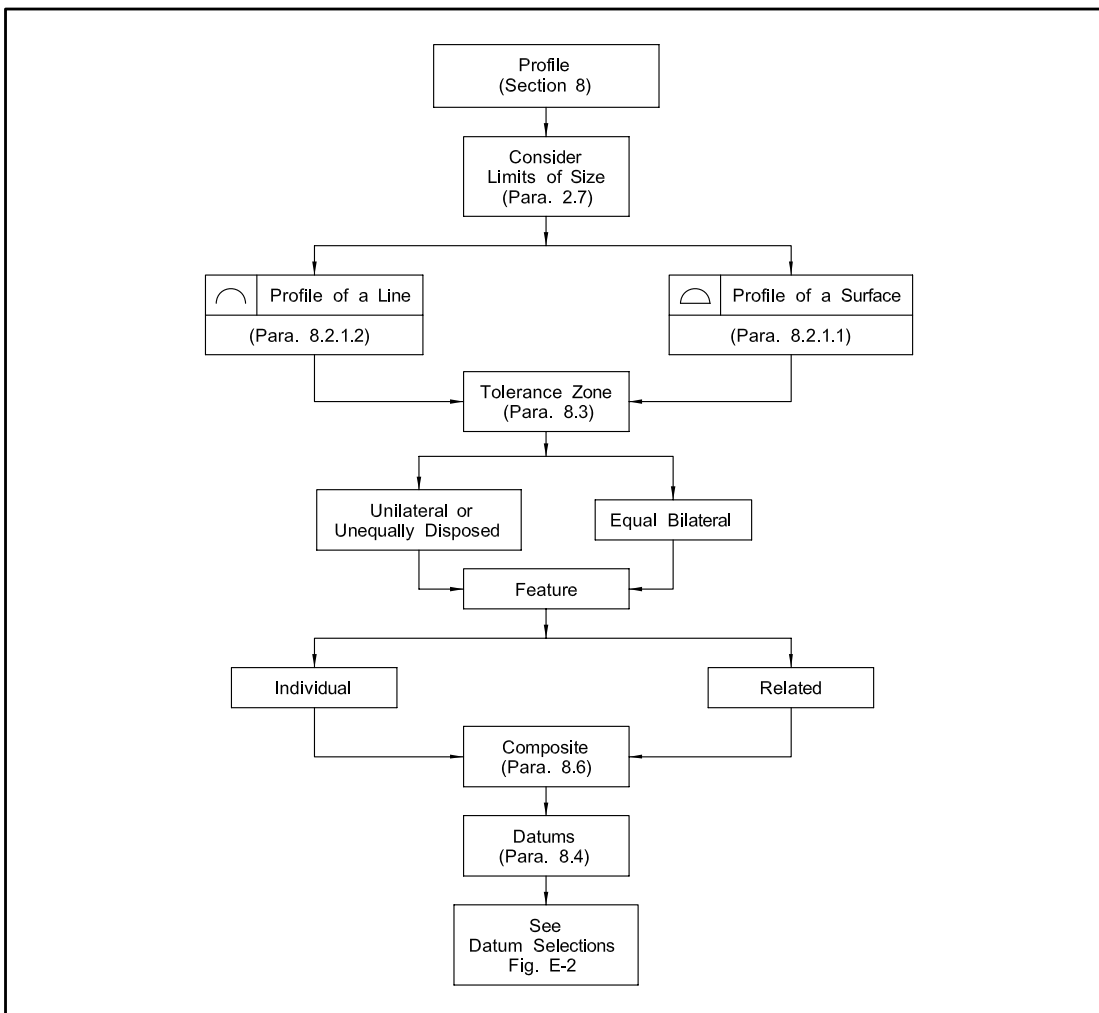
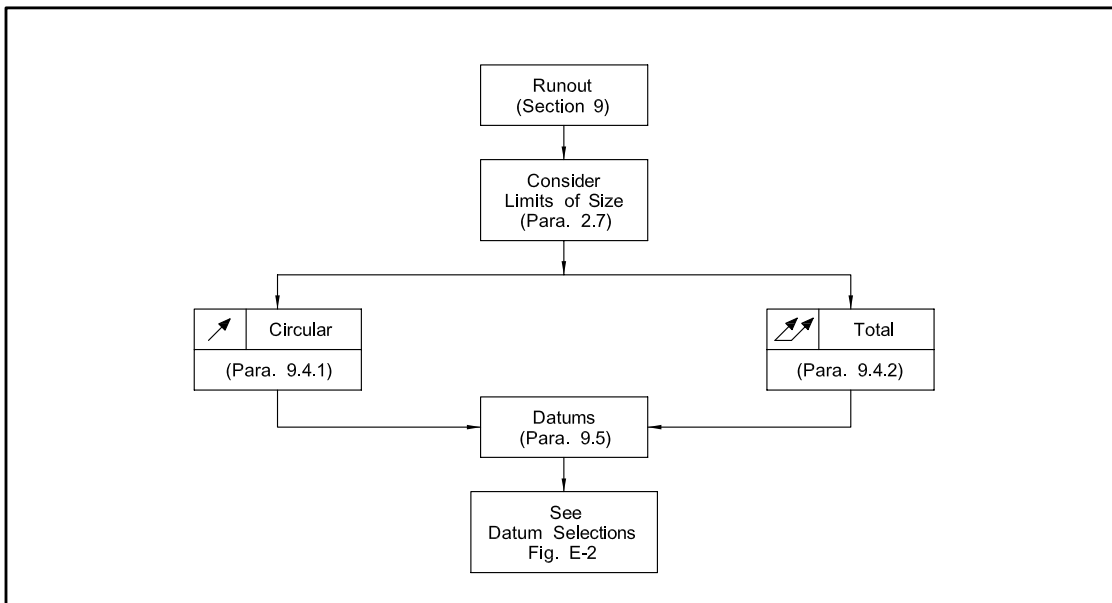


Fig. E-7 Runout



# Index

- Actual size
  - Actual local size, 1.3.53
  - Aligned dimensions, 1.7.1.1
  - Angle tolerances, 2.3.3
- All around
  - Specification, 8.3.1.4
  - Symbol, 3.3.19
- All over
  - Specification, 8.3.1.6
  - Symbol, 3.3.25
- Angles, 1.4(i), 1.4(j), 1.8.3, 2.1.1.3, 2.1.1.4
  - Implied 90°, 1.4(i), 1.4(j), 2.1.1.3
  - Implied 90° or 0° basic
  - Unspecified, 1.4(i), 1.4(j)
- Angular
  - Orientation, 4.9
  - Surfaces, 2.12
  - Units, 1.5.5
- Angularity, 6.3.1
  - Symbol, 3.3.1
  - Tolerance, 6.4.2
- Applications
  - Dimensions, 1.7, 7.2.1.1
  - Tolerances, 2.1.1
- Arc length symbol, 3.3.9
- Architectural drawing practices, 1.1
- Arcs, 1.8.3, 1.8.6
- Areas, datum target, 4.24.4
- Average diameter, 5.5.3
- Axis
  - X, 4.10.1, 4.21
  - Y, 4.10.1, 4.21
  - Z, 4.10.1, 4.21
  - Primary datum, 4.3, 4.11.4(a)
  - Secondary datum, 4.11.4(d)
  - Tertiary datum, 4.11.4(e)
- Base line dimensioning, 2.6(b)
- Basic angle, 1.4(j), 2.1.1.4, 6.4.2
- Basic dimension, 1.3.23
- Basic dimension symbol, 3.3.4
- Bilateral tolerance, 1.3.61, 8.3.1.1
- Bilateral tolerance
  - Unequally disposed, 8.3.1.2
- Boundary
  - Inner, 1.3.2
  - Least material (LMB), 1.3.3
  - Maximum material (MMB), 1.3.4
  - Outer, 1.3.5
  - Regardless of material (RMB), 1.3.49
- Capital letter notes, 1.1.5
- Center lines, 1.4(i), 1.4(j), 4.8.2
- Centers, machining, 1.8.15
- Chain dimensioning, 2.6(a)
- Chamfers, 1.8.16, 1.8.16.1
- Chords, 1.8.3
- Circularity
  - Symbol, 3.3.1
  - Tolerance, 5.4.3
- Civil engineering drawing practice, 1.1
- Coating, effect of, 2.4.1
- Coaxial features, 7.1(c), 7.4.2, 7.5.3, 7.6
- Code numbers, 1.4(h)
- Composite tolerancing
  - Positional, 7.5.1, 7.5.3.1, 7.5.4.2, 7.5.5
  - Profile, 8.6
- Computer-Aided Design, 1.4(b)
- Concentricity
  - Symbol, 3.3.1
  - Tolerance, 7.6.4
- Condition
  - Least material, 1.3.38
  - Maximum material, 1.3.39
  - Virtual, 1.3.67
- Conical tapers, 2.13
- Contacts, datum, 4.6, 4.7.1, 4.10.1(a), 4.10.1(b), 4.10.1(c)
- Control
  - Coaxiality, 7.6
  - Combined, 8.8
  - Concentricity, 7.6.4
  - Coplanarity, 8.4.1.1

- Composite, 7.5.1, 8.6
- Datum feature, 4.9
- Form, 5
- Profile, 8
- Runout, 9
- Conversion of units, 1.6.4
- Coordinate
  - Dimensioning, 1.9, 1.9.1, 1.9.2, 1.9.4
  - System, 1.4(p), 4.13
- Coplanarity, 8.4.1.1
- Corners, rounded, 1.8.5
- Counterbore symbol, 3.3.12
- Counterbored holes, 1.8.11, 7.4.2
- Countersink symbol, 3.3.14
- Countersunk holes, 1.8.12
- Cylindrical datum features, 4.10.3
- Cylindricity
  - Symbol, 3.3.1
  - Tolerance, 5.4.4
- Datum
  - Angular orientation, 4.5.2(b), 4.9, 4.10.3.3
  - Application
    - Customized datum reference frame, 4.23
    - Datum feature simulator, 4.18
    - MMB, LMB, and RMB to irregular features of size, 4.17
    - Restrained condition, 4.20
    - Theoretical and physical datum feature simulators, 4.6
  - Axis, 4.5(c)
    - Primary, 4.3, 4.10.3, 4.11.4(a)
    - Secondary, 4.11.4(d)
    - Single-axis two features, 4.12.2
    - Tertiary, 4.11.4(e)
  - Contact points, 4.11.1
  - Definition, 1.3.13
  - Establishing, 4.11
  - Feature, 1.3.16
    - Control, 4.9
    - Cylindrical, 4.10.3
    - LMB, 4.11.7, 4.11.8
    - MMB, 4.11.5, 4.11.6, 4.11.6.1, 4.11.6.2, 4.11.6.3
    - Multiple, 4.12
    - Order of precedence, 4.10
    - Partial surface, 4.12.5
    - Pattern, 4.12.3, 4.12.4
    - Permanent, 4.8.1
    - Primary, 4.3
    - Primary datum axis, 4.24.10
    - RMB, 4.11.4, 4.11.12, 4.12.4, 4.17
    - Secondary, 4.11.4, 4.24.12
    - Symbol, 3.3.2
    - Temporary, 4.8.1
    - Tertiary, 4.11.4(b)
    - Virtual condition, 1.3.67
- Gears, 2.10
- Order of precedence, 4.10
- Planes, 4.7.1, 4.24.8
- Reference frame, 4.1, 4.7
- Screw threads, 1.8.20, 2.9
- Secondary datum axis, 4.6, 4.11.3.3, 4.12.3(d), 4.12.8.3
- Splines, 2.10
- Target, 4.24
  - Areas, 4.24.4
  - Complex/irregular surfaces, 4.24.13
  - Dimensions, 4.16.7
  - Lines, 4.16.3
  - Movable, 4.24.6
  - Movable symbol, 3.3.27, 4.24.6
  - Points, 4.16.2
  - Symbol, 3.3.2
  - Tertiary, 4.11.4(e), 4.11.4(g)
  - Translation symbol, 3.3.26, 4.11.10, 4.16.9
- Decimal inch, 1.5.2, 1.6.2
- Decimal point, 1.6.3
- Definition of terms
  - Angularity, 1.3.1, 6.3.1
  - Boundary, inner, 1.3.2
  - Boundary, least material (LMB), 1.3.3
  - Boundary, maximum material (MMB), 1.3.4
  - Boundary, outer, 1.3.5
  - Circularity, 1.3.6, 5.4.3
  - Coaxiality, 1.3.7, 7.6
  - Complex feature, 1.3.8
  - Concentricity, 1.3.9, 7.6.4
  - Constraint, 1.3.11
  - Coplanarity, 1.3.10, 8.4.1.1
  - Cylindricity, 1.3.12, 5.4.4
  - Datum, 1.3.13
  - Datum axis, 1.3.14
  - Datum center plane, 1.3.15
  - Datum feature, 1.3.16
  - Datum feature simulator, 1.3.17
    - Datum feature simulator (theoretical), 1.3.17(a)
    - Datum feature simulator (physical), 1.3.17(b)
  - Datum reference frame, 1.3.18, 4.1
  - Datum simulated, 1.3.19

- Datum target, 1.3.20, 4.24
- Diameter, average, 1.3.21, 5.5.3
- Dimension, 1.3.22
- Dimension, basic, 1.3.23
- Dimension, reference, 1.3.24
- Envelope, actual mating, 1.3.25
  - Unrelated actual mating envelope, 1.3.25(a)
  - Related actual mating envelope, 1.3.25(b)
- Envelope, actual minimum material, 1.3.26
  - Unrelated actual minimum material envelope, 1.3.26(a)
  - Related actual minimum material envelope, 1.3.26(b)
- Feature, 1.3.27
- Feature, axis of, 1.3.28
- Feature, center plane of, 1.3.29
- Feature, derived median plane of, 1.3.30
- Feature, derived medial line of, 1.3.31
- Feature of size, 1.3.32
  - Regular feature of size, 1.3.32.1
  - Irregular feature of size, 1.3.32.2
- Feature control frame, 1.3.33
- Feature-relating tolerance zone framework (FRTZF), 1.3.34, 7.5.1(b), 8.6.1.3(b)
- Free state, 1.3.35
- Free-state variation, 1.3.36, 5.5
- Flatness, 1.3.37, 5.4.2
- Least material condition (LMC), 1.3.38
- Maximum material condition (MMC), 1.3.39
- Non-uniform tolerance zone, 1.3.40, 8.3.2
- Parallelism, 1.3.41, 6.3.2
- Pattern, 1.3.42
- Pattern-locating tolerance zone framework (FLTZF), 1.3.43, 8.6.1.3(a)
- Perpendicularity, 1.3.44, 6.3.3
- Plane, tangent, 1.3.45
- Position, 1.3.46, 7.2
- Profile, 1.3.47, 8.2
- Regardless of feature size (RFS), 1.3.48
- Regardless of material boundary (RMB), 1.3.49
- Restraint, 1.3.50
- Resultant condition, 1.3.51
- Runout, 1.3.52, 9.2
- Simultaneous requirement, 1.3.53, 4.19
- Size, actual local, 1.3.54
- Size, limits of, 1.3.55
- Size, nominal, 1.3.56
- Straightness, 1.3.57
- Statistical tolerancing, 1.3.58, 2.17
- Symmetry, 1.3.59, 7.7.2
- Tolerance, 1.3.60
  - Tolerance, bilateral, 1.3.61
  - Tolerance, geometric, 1.3.62
  - Tolerance, unilateral, 1.3.63
- True position, 1.3.64
- True profile, 1.3.65, 8.2
- Uniform tolerance zone, 1.3.66, 8.3.1
- Virtual condition, 1.3.67
- Degrees of freedom (DOF), 4.2, 4.3
- Depth symbol, 3.3.15
- Diameter, 1.8.1
  - Average, 5.5.3
  - Spherical, 7.4.6
  - Symbol, 3.3.7
- Dimension
  - Application, 1.7
  - Aligned, 1.7.1.1
  - Arrangement, 1.4(g)
  - Base line, 2.6(b)
  - Basic, 1.3.23, 7.2
  - Chain, 2.6(a)
  - Conical taper, 2.13
  - Conversion, 1.6.4
  - Coordinate, 1.9.1, 1.9.2, 1.9.4
  - Decimal inch, 1.6.2
  - Diameters, 1.8.1
  - Direct, 2.6(c)
  - Features, 1.8
  - Flat tapers, 2.14
  - Limited area, 1.7.3
  - Limit, 2.2(a), 2.4, 2.6.1
  - Line, 1.7.1
  - Maximum, 1.4(a), 2.5
  - Millimeter, 1.6.1
  - Minimum, 1.4(a), 2.5
  - Not to scale, 1.7.9
  - Origin of, 2.6.1
  - Origin symbol, 3.3.17
  - Overall, 1.7.7
  - Plus and minus, 2.2(b)
  - Polar coordinates, 1.9.4, 7.4.4.2
  - Radii, 1.8.2
  - Reading direction, 1.7.5
  - Rectangular coordinate, 1.9.1, 1.9.2, 7.4.4.1
  - Reference, 1.3.24, 1.7.6
  - Repetitive, 1.9.5
  - Rounded corners, 1.8.5

- Rounded ends, 1.8.4
- Round holes, 1.8.10
- Rounding off, 1.6.4
- Rules for, 1.4, 2.7.1
- Selection, 1.4(d)
- Series and patterns, 1.9.5.1
- Spacing, 1.9.5.2
- Tabular, 1.9.3
- True radius, 1.8.2.3
- Types of, 1.6
- Within outline of view, 1.7.8
- Direct dimensioning, 2.6(c)
- Documents, reference, 1.2
- Drawing practices
  - Architectural, 1.1
  - Civil engineering, 1.1
  - Welding, 1.1
- Drawings, undimensioned, 1.4(b)
- Dual dimension, units, 1.5.4
  
- Effect of LMC, 2.8.4
- Effects of zero tolerance at LMC, 2.8.5
- Effect of MMC, 2.8.2
- Effects of zero tolerance at MMC, 2.8.3
- Effect of RFS, 2.8.1
- Effect of surface coating, 2.4.1
- Ends, rounded, 1.8.4
- Equal spacing, 1.9.5.2
- Extension lines, 1.7.2
  
- Fastener
  - Fixed, B.4
  - Floating, B.3
- Feature
  - Center distance, 7.1(a), (d)
  - Control datum, 4.9
  - Control frame, 3.4
  - Datum, 1.3.16, 4.1, 4.3
    - Cylindrical, 4.10.3
    - LMB, 4.11.7, 4.11.8
    - MMB, 4.11.5, 4.11.6
    - RMB, 4.3, 4.11.4, 4.11.12
    - Shift/displacement, 4.11.9
    - Simulator, 4.6
    - Temporary, 4.8.1
  - Definition, 1.3.27
  - Dimensioning, 1.8
  - Interrelated, 2.7.4
  - Location, 1.9
    - Multiple patterns, 7.5.4.1, 7.5.4.2
    - Noncircular, 7.6.1
    - Pattern location, 7.5
    - Relationship, 2.7.4
    - Repetitive, 1.9.5
    - Restrained, 4.20, 5.5.2
    - Size, 1.3.32
      - Regular, 1.3.32.1
      - Irregular, 1.3.32.2
    - Spherical, 7.4.6
    - Symmetrical, 7.7
  - Finish, 2.4.1
  - Fixed fastener formula, B.4
  - Flat tapers, 2.14
  - Flatness
    - Symbol, 3.3.1
    - Tolerance, 5.4.2
  - Floating fastener formula, B.3
  - Forgings, 1.8.23
  - Form
    - Control, 5
    - Perfect at MMC, 2.7.1
    - Tolerance, specifying, 5.3
    - Tolerance, zero, 2.7.4(a), 2.8.3
    - Variations, 2.7.1
  - Former practices, Nonmandatory Appendix D
    - Specification of RFS for positional tolerances, D.2
    - Specification of straightness to control the flatness of a derived median plane, D.3
    - MMC, LMC, and RFS for datum features, D.4
  - Formula, positional tolerances, Nonmandatory Appendix B
  - Frame, datum reference, 4.7
  - FRTZF, 1.3.34
  - Free-state variation, 2.7.2(b), 5.5
  - Fundamental rules, dimensioning, 1.4
    - Gage, functional, 7.3.6.2.2(b)
    - Gaging, reference to, 1.1.6
    - Gears, 1.8.22, 2.10
    - General tolerance note, 2.1.1(e)
    - Geometric characteristic symbols, 3.3.1, Nonmandatory Appendix C
    - Geometric tolerance, 1.3.62
  - Holes
    - Axis, 7.3.3.1(b)
    - Clearance, 7.4.1.1
    - Coaxial, 7.5.3
    - Counterbored, 1.8.11, 7.4.2

- Counterdrilled, 1.8.12
  - Countersunk, 1.8.12
  - Nonparallel, 7.4.7
  - Round, 1.8.10
  - Surface of, 7.3.3.1(a)
- Identification of linear units, 1.5.3
- International System of Units, SI, 1.1.2
- Irregular outlines, 1.8.7
- Keyseats, 1.8.17
- Knurling, 1.8.18
- Least material boundary, 1.3.3
- Least material condition, 1.3.38, 2.8, 2.8.4, 7.3.5
- Limit dimensioning, 2.1.1(a), 2.2(a), 2.4, 2.5
- Limits, 2.1.1(a), 2.4
  - Interpretation of, 2.4
  - Single, 2.5
- Limits and fits, 2.2.1, B.7
- Limits of size, 1.3.55, 2.7
- Limited segment of a profile, 8.3.1.5
- Linear units
  - Dual, 1.5.4
  - Identification, 1.5.3
- Lines
  - Chain, 1.7.3.1
  - Datum target, 3.3.3.2, 4.24.3
  - Dimension, 1.7.1
  - Extension, 1.7.2
  - Leader, 1.7.4
  - Profile of, 8.2.1.2
- LMB
  - Applicability, 4.11.7
  - Datum feature displacement, 7.3.6.3
  - Definition, 1.3.3
  - Effect of, 4.11.3
  - Irregular feature of size, 4.17
  - Symbol, 3.3.5
- LMC
  - Applicability, 2.8
  - Definition, 1.3.38
  - Effect of, 2.8.4
  - Positional tolerancing, 7.3.5
  - Symbol, 3.3.5
  - Zero tolerancing, 2.8.5, 7.3.5.3
- Location of features, 1.9
- Machining centers, 1.8.15
- Manufacturing processes, 1.4(e)
- Maximum material boundary, 1.3.4
- Maximum material condition, 1.3.39, 2.8, 2.8.2
- Measurement, units of, 1.5
- Metric limits and fits, 2.2.1
- Metric linear units, 1.5.1
- Millimeter dimensions, 1.6.1
- MMB
  - Applicability, 4.11.5
  - Definition, 1.3.4
  - Effect of, 4.11.3
  - Irregular feature of size, 4.17
  - Symbol, 3.3.5
- MMC
  - Applicability, 2.8
  - Definition, 1.3.39
  - Effect of, 2.8.2
  - Perfect form, 2.7.1
  - Positional tolerancing, 7.3.3
  - Symbol, 3.3.5
  - Zero tolerancing, 2.8.3, 6.6.4, 7.3.4
- Noncircular features, 7.4.5
- Nonmandatory dimensions, 1.4(f)
- Nonrigid parts, 5.5
- Nonparallel holes, 7.4.7
- Note, general, 1.4(a), 1.7, 2.1.1.2(b), 8.2.3
- Notes, 1.1.5, 1.7.5.1, 3.2
- Origin of dimension, 2.6.1
- Outlines
  - Arcs, 1.8.6
  - Circular, 1.8.7
  - Dimension within, 1.7.8
  - Irregular, 1.8.7
  - Noncircular, 1.8.7
  - Symmetrical, 1.8.9
- Orientation
  - Control, 6.2
  - Tolerance, 6.4
- Overall dimension, 1.7.7
- Parallelism, 6.3.2
  - Symbol, 3.3.1
  - Tolerance, 6.4.2
- Pattern, feature, 7.5
- Patterns, multiple, 7.5.4.1, 7.5.4.2
- Perfect form, MMC, 2.7.1
- Perpendicularity, 6.3.3

- Symbol, 3.3.1
- Tolerance, 6.4.2
- Planes, datum, 4.10.3, 4.16.3, 4.16.4, 4.16.5, 4.16.6, 4.16.7, 4.24.8
- Plated parts, 2.4.1
- PLTZF, 1.3.43, 7.5.1(a), 8.6.1.3(a)
- Plus and minus dimensioning, 2.2(b)
- Points, datum targets, 3.3.3.1, 4.24.2
- Polar coordinate dimensioning, 1.9.4, 7.4.4.2
- Positional tolerancing, 7
  - Bidirectional, 7.4.4
  - Coaxial controls, 7.6.1, 7.6.2.1, 7.6.2.2, 7.6.2.3
  - Composite, 7.5.1
  - Conical zone, 7.4.3
  - Formulas, Nonmandatory Appendix B
  - Fundamental explanation, 7.2
  - LMB, 7.3.6, 7.3.6.3
  - LMC, 2.8, 7.3.5
  - Material condition, 7.3.1
  - MMB, 7.3.6, 7.3.6.2, 7.5.4.2
  - MMC, 2.8, 7.3.3
  - Noncircular, 7.4.5
  - Rectangular coordinate, 7.4.4.1
  - RMB, 7.3.6.1, 7.5.4.1
  - RFS, 2.8, 7.3.2, 7.7.1.2
  - Spherical features, 7.4.6
  - Symmetrical, 7.7
  - Zero, LMC, 2.8.5, 7.3.5.3
  - Zero, MMC, 2.8.3, 7.3.4
- Position symbol, 3.3.1
- Position, true, see *Positional tolerancing*
- Precedence, datum, 4.10
- Preferred sizes, B.7
- Primary datum feature, 4.3
- Profile for conical feature, 8.4.2
- Profile of
  - Line symbol, 3.3.1
  - Line tolerance, 8.2.1.2
  - Surface symbol, 3.3.1
  - Surface tolerance, 8.2.1.1
- Profile tolerancing, 8.2
  - Combined controls, 8.8
  - Composite, 8.6
  - Coplanar surface, 8.4.1.1
  - Tolerance zone, 8.3
- Projected tolerance zone, 7.4.1, 7.5.1.7, B4
- Projected tolerance zone symbol, 3.3.6
- Processing, 1.4(e)
- Processing information, nonmandatory, 1.4(f)
- Radius, 1.8.2, 2.15.1
  - Spherical, 1.8.2.5
  - Symbol, 3.3.7
  - Tangent, 2.15.1
- Radius, controlled, 2.15.2
  - Symbol, 3.3.7
- Rectangular coordinate, 7.4.4.1
- Reference
  - Dimension, 1.7.6
  - Symbol, 3.3.8
  - To gaging, 1.1.6
  - To this Standard, 1.1.3
- Regardless of feature size, 1.3.48, 2.8, 2.8.1, 7.3.2
- Regardless of material boundary, 1.3.49
- Repetitive dimensions, 1.9.5
- Repetitive features, 1.9.5
- Resultant condition, 1.3.51
- RFS
  - Applicability, 2.8
  - Definition, 1.3.48
  - Effect of, 2.8.1
  - Positional tolerancing, 7.3.2
  - Symbol, 3.3.5
- RMB
  - Applicability, 4.3
  - Definition, 1.3.49
  - Effect of, 2.8.1
  - Irregular feature of size, 4.17
  - Symbol, 3.3.5
- Rods, 1.8.19
- Round hole, 1.8.10
- Rounded corners, 1.8.5
- Rounded ends, 1.8.4
- Rounding dimensions, 1.6.4
- Roundness tolerance, 5.4.3
- Rules for dimensioning, 1.4
- Runout
  - Control, 9.2
  - Symbols, 3.3.1
  - Tolerance, 9.3, 9.4
    - Circular, 9.4.1
    - Total, 9.4.2
- Scale, dimensions not to, 1.7.9
- Screw threads, 1.8.20
  - Tolerancing, 2.9
- Size
  - Actual local, 1.3.54
  - "BY" (X), 1.9.6



- Limits of, 2.7
- Stock, 1.4(a), 2.7.2(a)
- Variation, 2.7.1(b)
- Slope symbol, 3.3.18
- Specifying form tolerances, 5.3
- Spherical features, positional tolerancing, 7.4.6
- Spherical radius, 1.8.2.5
- Splines, 2.10
- Spotface, 1.8.14
- Spotface symbol, 3.3.13
- Square symbol, 3.3.16
- Standard, reference to, 1.1.3
- Straightness
  - Symbol, 3.3.1
  - Tolerance, 5.4.1
- Studs, 7.4.1
- Surfaces
  - Angular, 2.12
  - Coplanar, 8.4.1.1
  - Profile of, 8.2.1.1
- Surface texture, 1.8.2.1
- Symbols, 1.1.7
  - All around, 3.3.19
  - All over, 3.3.25
  - Arc length, 3.3.9
  - Basic dimension, 3.3.4
  - Between, 3.3.11
  - Comparison, C.3
  - Construction, 3.3
  - Continuous feature, 3.3.23
  - Counterbore, 3.3.12
  - Countersink, 3.3.14
  - Datum feature, 3.3.2
  - Datum reference frame, 3.3.30
  - Datum target, 3.3.3
    - Areas, 3.3.3.3
    - Lines, 3.3.3.1
    - Points, 3.3.3.2
  - Datum translation, 3.3.26
  - Depth, 3.3.15
  - Diameter, 3.3.7
  - Dimension origin, 3.3.17
  - Feature control, frame, 3.4
  - Free state, 3.3.20
  - Geometric characteristic, 3.3.1
  - Independency, 3.3.24
  - Limits and fits, 3.3.29
  - Material boundary, 3.3.5
  - Material condition, 3.3.5
  - Moveable datum target, 3.3.27, 4.24.6
  - Projected tolerance zone, 3.3.6
  - Radius, 3.3.7
  - Radius, controlled, 3.3.7
  - Radius, spherical, 3.3.7
  - Reference, 3.3.8
  - Slope, 3.3.18
  - Spotface, 3.3.12
  - Statistical tolerance, 3.3.10
  - Surface texture, 3.3.28
  - Tangent plane, 3.3.21
  - Taper, 3.3.17
  - Tolerance zone identification, 3.6
  - Unequally disposed profile, 3.3.22
- Symmetrical outlines, 1.8.9
- Symmetry, 7.7.2
- Tabular dimensioning, 1.9.3
- Tabulated tolerances, 3.7
- Tangent plane symbol, 3.3.21
- Tangent radii, 2.16
- Taper symbol, 3.3.18
- Tapers
  - Conical, 2.13
  - Flat, 2.14
- Target
  - Datum, 4.24
  - Datum, area, 4.24.4
  - Datum dimensions, 4.24.7
  - Datum line, 4.24.3
  - Datum planes, 4.24.5
  - Datum points, 4.24.2
  - Datum symbol, 4.24.1
- Temporary datum feature, 4.8.1
- Tertiary datum, 4.9(c), 4.11.4(e)
- Threads, 1.8.20, 2.9
- Three-plane relationship, 4.1
- Tolerance
  - Accumulation, 2.6
  - Angularity, 6.3.1
  - Application, 2.1.1
  - Base line, 2.6(b)
  - Bilateral, 1.3.61
  - Chain, 2.6(a)
  - Circularity, 5.4.3
  - Coatings, effects of, 2.4.1
  - Combination, see *Virtual condition*

- Composite, position, 7.5.1
- Composite, profile, 8.6
- Conical zone, 7.4.3
- Cylindricity, 5.4.4
- Decimal inch, 2.3.2
- Definition, 1.3.60
- Direct, 2.2, 2.6(c)
- Expression, 2.3
- Flatness, 5.4.2
- Form, 5.4
- Gears, 2.10
- General, 2
- Geometric, 1.3.62
- Inch, 2.3.2
- Limit, 2.1.1(a)
- Limit of size, 1.3.55, 2.7
- Limits and fits, 2.2.1
- Limits, interpretation, 2.4
- Location, 7
- Metric, 2.2.1, 2.3.1
- Note, 2.1.1(c)
- Orientation, 6
- Parallelism, 6.3.2
- Perpendicularity, 6.3.3
- Plating, effects of, 2.4.1
- Polar coordinates, 7.4.4.2
- Positional, 7.2, 7.3, 7.4
  - Bidirectional, 7.4.4
  - Composite, 7.5.1
  - Formulas, Nonmandatory Appendix B
  - LMC, 2.8, 2.8.4, 7.3.5
  - MMC, 2.8, 2.8.2, 7.3.3
  - RFS, 2.8, 2.8.1, 7.3.2
  - Zero MMC, 2.8.3, 7.3.4
  - Zero LMC, 2.8.5, 7.3.5.3
- Plus and minus, 2.2(b)
- Profile, 8
- Roundness, 5.4.3
- Runout, 9
- Screw threads, 1.8.20, 2.9
- Single limits, 2.5
- Size, limits of, 2.7
- Splines, 2.10
- Straightness, 5.4.1
- Tabulated tolerances, 3.7
- Tolerance of location, 7
- Unequally disposed profile, 8.3.1.2
- Unilateral tolerance, 1.3.63, 8.3.1.2
- Zero, 2.8.3, 2.8.5, 7.3.4, 7.3.5.3, 7.7.1.1
- Zone
  - Definition, 3.6
  - Projected, 7.4.1
- True position, 1.3.64
- True radius, 1.8.2.3
- Tubing, 1.8.19
- Types of dimensions, 1.6
- Undimensioned drawing, 1.4(b)
- Unilateral tolerance, 1.3.63
- Units, 1.1.2
- Units of measure, 1.5
  - Angular, 1.5.5
  - Linear
    - Dual, 1.5.4
    - Identification, 1.5.3
    - Metric, 1.5.1
    - U.S. Customary, 1.5.2
- Unspecified angles, 2.1.1.3, 2.1.1.4
- Virtual condition, 1.3.67
- "X" (BY), 1.9.6
- Zero form tolerance, 2.7.1
- Zero positional tolerance, 7.3.4, 7.3.5.3
  - LMC, 7.3.5.3
  - MMC, 7.3.4
- Zero tolerance, 2.8.3, 2.8.5
- Zone tolerance, projected, 7.4.1

# ASME Y14.5-2009

.....

ASME also provides you an integrated suite of related offerings on geometric dimensioning and tolerancing (GD&T):

- Standards;
- Personnel Certifications;
- Handbooks, and;
- Training Courses.

Build your design expertise, direct from the GD&T source!

For details, call 1-800-THE-ASME (843-2763) or visit [go.asme.org/gdt](http://go.asme.org/gdt).

ISBN-13 : 978-0-7918-3192-2  
ISBN-10 : 0-7918-3192-2

